

# Fiberglass



We offer two fire retardant (FR) resins for strut systems, polyester and vinyl ester. Both resins are ideal for corrosive environments.

While polyester is sufficient for most uses, vinyl ester is suitable for a broader range of environments.

Please refer to the "Corrosion Resistance Guide" for specific applications, page 184.

## Materials & Finishes

Our Fiberglass Strut systems are manufactured from glass fiber-reinforced plastic shapes that meet ASTM E-84, Class 1 Flame Rating and self-extinguishing requirements of ASTM D-635. A surface veil is applied during pultrusion to insure a resin-rich surface and ultraviolet resistance.

## Fittings

The following dimensions apply to all fittings except as noted on the drawings:

Hole Size –  $1\frac{3}{32}$ " (10.3 mm) Dia.

Hole Spacing –  $1\frac{3}{16}$ " (20.6 mm) from end and  $1\frac{7}{8}$ " (47.6 mm) on center.

Width –  $1\frac{5}{8}$ " (41.3 mm)

Thickness –  $\frac{1}{4}$ " (6.3 mm)

## Metric

Metric dimensions are shown in parentheses. Unless noted, all metric dimensions are in millimeters.

## Channel Resin Information

We offer two fire retardant (FR) resins for strut systems, polyester and vinyl ester. Both resins are ideal for corrosive environments. While polyester is sufficient for most uses, vinyl ester is suitable for a broader range of environments. Please refer to the "Corrosion Resistance Guide" below for specific applications.

**Corrosion Resistance Guide**

Chemicals	70°F (21°C)	160°F (71°C)	Chemicals	70°F (21°C)	160°F (71°C)
Acetic acid 5%	BFP/BFV	BFP/BFV	Methyl alcohol 10%	BFP/BFV	BFV-150° **
Acetic acid 52%	BFP/BFV	BFV-210° **	Naphtha	BFP/BFV	BFP/BFV
Aluminum potassium sulfate 5%	BFP/BFV	BFP/BFV	Nitric acid 5%	BFP/BFV	BFP/BFV
Ammonium hydroxide 10%	BFP/BFV	BFV-150° **	Nitric acid 20%	BFV	BFV-120° **
Ammonium nitrate	BFP/BFV	BFP/BFV	Phosphoric acid 10%	BFP/BFV	BFP/BFV
Benzene sulfonic acid 5%	BFP/BFV	BFP/BFV	Phosphoric acid 30%	BFP/BFV	BFP/BFV
Calcium chloride	BFP/BFV	BFP/BFV	Phosphoric acid 85%	BFP/BFV	BFP/BFV
Carbon tetrachloride	BFV	BFV-100° **	Sodium bicarbonate 10%	BFP/BFV	BFP/BFV
Chlorine dioxide 15%	BFP/BFV	BFV-150° **	Sodium bisulfate	BFP/BFV	BFP/BFV
Chromic acid 5%	BFV	BFV-150° **	Sodium carbonate	BFP/BFV	BFV
Copper sulfate	BFP/BFV	BFP/BFV	Sodium chloride	BFP/BFV	BFP/BFV
Diesel fuel	BFP/BFV	BFV	Sodium hydroxide 1-50%	BFV	BFV-120° **
Ethylene glycol	BFP/BFV	BFP/BFV	Sodium hypochlorite 5%	BFP/BFV	BFV-120° **
Fatty acids 100%	BFP/BFV	BFP/BFV	Sodium nitrate	BFP/BFV	BFP/BFV
Ferrous sulfate	BFP/BFV	BFP/BFV	Sodium silicate	BFP/BFV	BFV-210° **
Fluosilicic acid 0-20%	BFV	BFV	Sodium sulfate	BFP/BFV	BFP/BFV
Gasoline	BFP/BFV	BFV	Sulfuric acid 0-30%	BFP/BFV	BFP/BFV
Hydrochloric acid 1%	BFP/BFV	BFP/BFV	Sulfuric acid 30-50%	BFV	BFV
Hydrochloric acid 15%	BFP/BFV	BFV-180° **	Sulfuric acid 50-70%	BFV	BFV-180° **
Hydrochloric acid 37%	BFP/BFV	BFV-150° **	Trisodium phosphate 25%	BFP/BFV	BFV-210° **
Kerosene	BFP/BFV	BFP/BFV	Trisodium phosphate-All	BFV	BFV-210° **
Magnesium chloride	BFP/BFV	BFP/BFV	Water, Distilled	BFP/BFV	BFP/BFV

BFP - BFP parts recommended    BFV - BFV parts recommended    \*\* - Not recommended to exceed this temperature

Information contained in this chart is based on data from raw material suppliers.

Temperatures are not the minimum nor the maximum (except where specifically stated) but represent standard test conditions. The products may be suitable at higher temperatures but individual test data should be required to establish suitability.

The recommendations or suggestions contained in this chart are made without guarantee or representation as to results. We suggest that you evaluate the recommendations and suggestions in your own laboratory or actual field trial prior to use.

### Recommended Guideline:

Temperature	Design Load Multiplier
75°F (24°C)	100%
100°F (38°C)	90%
125°F (52°C)	78%
150°F (66°C)	68%
175°F (79°C)	60%
200°F (93°C)	52%

Flame Retardant Properties	BFP	BFV
Flame Resistance (FTMS 406-2023) ign/burn, seconds	75/75	75/75
Intermittent Flame Test (HLT-15), rating	100	100
Flammability Test (ASTM D635) Ignition Burning Time	none 0 sec.	none 0 sec.
Surface Burning Characteristics (ASTM E84), Flame spread index	25	25
UL 94 Flame Class	V-0	V-0

Reference page 183 for general fitting specifications.

# Fiberglass

## BFP22 THRU BFV22SH

- Channel lengths: 10 Ft. (3.05 m) and 20 Ft. (6.09 m)
- Fiberglass strut meets specification of ASTM D-4385 Levels III and IV.

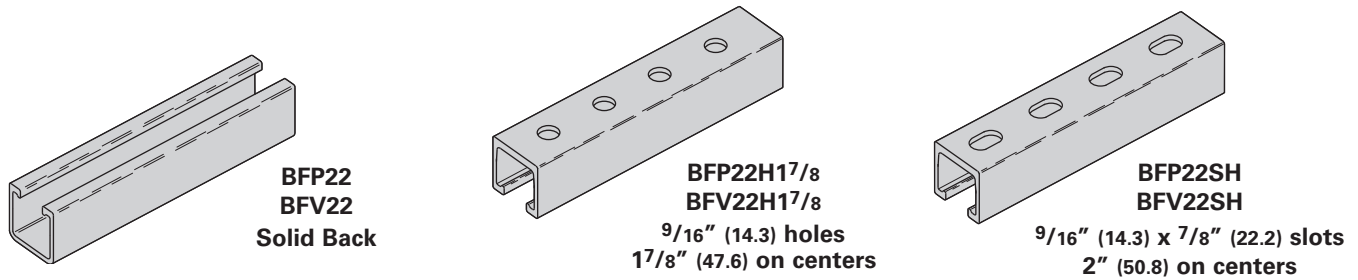

Part No.	Material	Description	Color	Weight	
				Lbs./ft.	kg/m
<b>BFP22*</b>	Polyester Resin	Solid Back	Gray	.63	(.94)
<b>BFV22*</b>	Vinyl Ester Resin	Solid Back	Beige	.63	(.94)
<b>BFP22H1 7/8*</b>	Polyester Resin	Holes in Back	Gray	.60	(.89)
<b>BFV22H1 7/8*</b>	Vinyl Ester Resin	Holes in Back	Beige	.60	(.89)
<b>BFP22SH*</b>	Polyester Resin	Slots in Back	Gray	.61	(.91)
<b>BFV22SH*</b>	Vinyl Ester Resin	Slots in Back	Beige	.61	(.91)

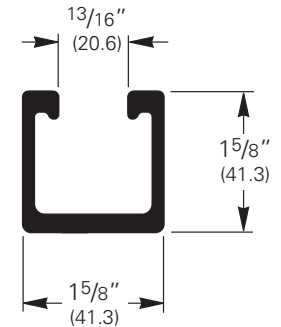

\* Insert -10 for 10'-0" (3.05 m) length or -20 for 20'-0" (6.09 m) length

## BFP22A BFV22A

- Channel Lengths: 10 Ft. (3.05 m) and 20 Ft. (6.09 m)
- Fiberglass strut meets specification of ASTM D-4385 Levels III and IV.

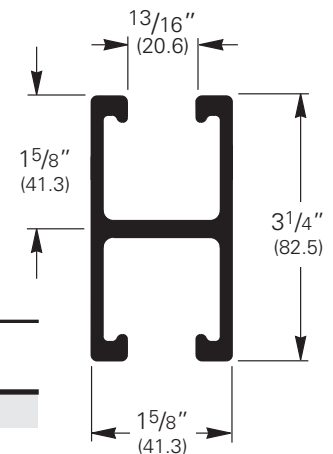
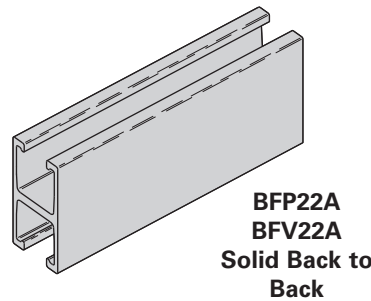

Part No.	Material	Description	Color	Weight	
				Lbs./ft.	kg/m
<b>BFP22A*</b>	Polyester Resin	Back To Back	Gray	1.15	(1.71)
<b>BFV22A*</b>	Vinyl Ester Resin	Back To Back	Beige	1.15	(1.71)

\* Insert -10 for 10'-0" (3.05 m) length or -20 for 20'-0" (6.09 m) length

### Field Cutting Sealant Kits

**RSK010** Pint Sealing Kit (473 cm<sup>3</sup>) includes sealant and brush applicator

- Seals exposed fibers after field cutting. •
- UV resistant •

Published design loads on page 187 are based on usage at 70°F (21°C) and must be reduced for continuous exposure to higher temperatures. Refer to the chart below for high temperature applications.

Temperature	Design Load Multiplier
75°F (24°C)	100%
100°F (38°C)	90%
125°F (52°C)	78%
150°F (66°C)	68%
175°F (79°C)	60%
200°F (93°C)	52%

APPROPRIATE PROTECTIVE CLOTHING AND RESPIRATORY PROTECTION DEVICE SHOULD BE WORN WHEN FIELD CUTTING OR GRINDING FIBERGLASS.

Reference page 183 for general fitting specifications.

## Beam Loading Data for Glass Reinforced Polyester Resin

Beam Span		Part No.	Maximum Allowable Beam Load		Deflection @ Maximum Allowable Beam Load		Allowable Load @ Deflection =				
			Lbs.	kN	in.	mm	1/240 Span		1/360 Span		
in.	mm							Lbs.	kN	Lbs.	kN
12"	(305)	<b>BFP22</b>	1781	(7.92)	0.064	(1.62)	1392	(6.19)	928	(4.13)	
		<b>BFP22A</b>	2259	(10.05)	0.037	(.94)	2259	(10.05)	2051	(9.12)	
24"	(609)	<b>BFP22</b>	890	(3.96)	0.256	(6.50)	347	(1.54)	231	(1.03)	
		<b>BFP22A</b>	1127	(5.01)	0.147	(3.73)	767	(3.41)	511	(2.27)	
36"	(914)	<b>BFP22</b>	592	(2.63)	0.576	(14.63)	153	(0.68)	101	(0.45)	
		<b>BFP22A</b>	750	(3.33)	0.330	(8.38)	338	(1.50)	224	(0.99)	
48"	(1219)	<b>BFP22</b>	443	(1.97)	1.024	(26.01)	85	(0.38)	55	(0.24)	
		<b>BFP22A</b>	560	(2.49)	0.587	(14.91)	188	(0.83)	123	(0.55)	
60"	(1524)	<b>BFP22</b>	353	(1.57)	1.600	(40.64)	53	(0.23)	34	(0.15)	
		<b>BFP22A</b>	446	(1.98)	0.918	(23.32)	117	(0.52)	76	(0.34)	
72"	(1829)	<b>BFP22</b>	293	(1.30)	2.303	(58.49)	35	(0.15)	22	(0.10)	
		<b>BFP22A</b>	370	(1.64)	1.322	(33.58)	78	(0.34)	50	(0.22)	
96"	(2438)	<b>BFP22</b>	218	(0.97)	4.095	(104.01)	17	(0.07)	9	(0.04)	
		<b>BFP22A</b>	273	(1.21)	2.350	(59.69)	39	(0.17)	23	(0.10)	
120"	(3048)	<b>BFP22</b>	172	(0.76)	6.398	(162.51)	8	(0.03)	3	(0.01)	
		<b>BFP22A</b>	214	(0.95)	3.671	(93.24)	19	(0.08)	9	(0.04)	

## Beam Loading Data for Glass Reinforced Vinyl Ester Resin

Beam Span		Part No.	Maximum Allowable Beam Load		Deflection @ Maximum Allowable Beam Load		Allowable Load @ Deflection =				
			Lbs.	kN	in.	mm	1/240 Span		1/360 Span		
in.	mm							Lbs.	kN	Lbs.	kN
12"	(305)	<b>BFV22</b>	2220	(9.87)	0.071	(1.80)	1568	(6.97)	1045	(4.65)	
		<b>BFV22A</b>	6442	(28.65)	0.039	(0.99)	6442	(29.65)	5549	(24.68)	
24"	(609)	<b>BFV22</b>	1109	(4.93)	0.283	(7.19)	391	(1.74)	260	(1.15)	
		<b>BFV22A</b>	3219	(14.32)	0.155	(3.94)	2079	(9.25)	1385	(6.16)	
36"	(914)	<b>BFV22</b>	738	(3.28)	0.637	(16.18)	172	(0.76)	114	(0.51)	
		<b>BFV22A</b>	2144	(9.53)	0.348	(8.84)	922	(4.10)	613	(2.72)	
48"	(1219)	<b>BFV22</b>	553	(2.46)	1.133	(28.78)	96	(0.43)	63	(0.28)	
		<b>BFV22A</b>	1606	(7.14)	0.619	(15.72)	516	(2.29)	342	(1.52)	
60"	(1524)	<b>BFV22</b>	441	(1.96)	1.770	(44.96)	60	(0.26)	39	(0.17)	
		<b>BFV22A</b>	1283	(5.70)	0.967	(24.56)	327	(1.45)	216	(0.96)	
72"	(1829)	<b>BFV22</b>	366	(1.63)	2.549	(64.74)	40	(0.18)	25	(0.11)	
		<b>BFV22A</b>	1067	(4.74)	1.393	(35.38)	224	(0.99)	147	(0.65)	
96"	(2438)	<b>BFV22</b>	273	(1.21)	4.531	(115.09)	19	(0.08)	11	(0.05)	
		<b>BFV22A</b>	796	(3.54)	2.477	(62.91)	121	(0.54)	78	(0.34)	
120"	(3048)	<b>BFV22</b>	216	(0.96)	7.079	(179.80)	9	(0.04)	7	(0.02)	
		<b>BFV22A</b>	633	(2.81)	3.870	(98.30)	72	(0.32)	44	(0.19)	

## Loading Information

### Beam Loads:

The above charts list the total allowable uniform load for various simple spans based on a minimum safety factor of 2. If the load is concentrated at center span, multiply the load from the above charts by 0.5 and the corresponding deflection by 0.8.

All beams should be supported in a manner to prevent rotation at supports. Long, deep beams should be tied between supports to prevent twist. For channels with holes or slots use 90% of recommended load shown in channel loading chart.

Reference page 183 for general fitting specifications.

# Fiberglass

## BFP42 thru BFV42SH

- Channel lengths: 10 Ft. (3.05 m) and 20 Ft. (6.09 m)
- Fiberglass strut meets specification of ASTM D-4385 Levels III and IV.

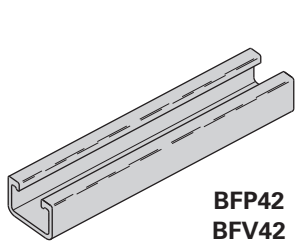

**BFP42  
BFV42  
Solid Back**

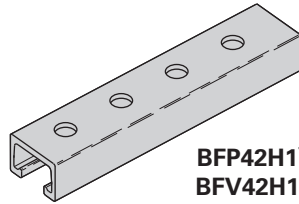

**BFP42H17/8  
BFV42H17/8**  
9/16" (14.3) holes  
17/8" (47.6) on centers

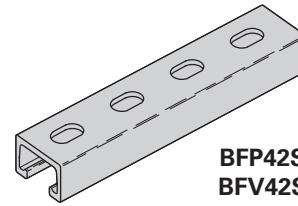

**BFP42SH  
BFV42SH**  
9/16" (14.3) x 7/8" (22.2) slots  
2" (50.8) on centers

Part No.	Material	Description	Color	Weight	
				Lbs./ft.	kg/m
<b>BFP42*</b>	Polyester Resin	Solid Back	Gray	.48	(.71)
<b>BFV42*</b>	Vinyl Ester Resin	Solid Back	Beige	.48	(.71)
<b>BFP42H17/8*</b>	Polyester Resin	Holes in Back	Gray	.46	(.68)
<b>BFV42H17/8*</b>	Vinyl Ester Resin	Holes in Back	Beige	.46	(.68)
<b>BFP42SH*</b>	Polyester Resin	Slots in Back	Gray	.47	(.70)
<b>BFV42SH*</b>	Vinyl Ester Resin	Slots in Back	Beige	.47	(.70)

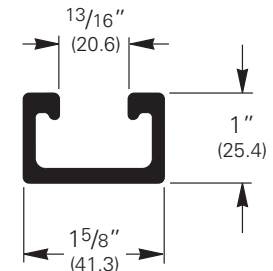

\* Insert -10 for 10'-0" (3.05 m) length or -20 for 20'-0" (6.09 m) length

## BFP42A BFV42A

- Channel lengths: 10 Ft. (3.05 m) and 20 Ft. (6.09 m)
- Fiberglass strut meets specification of ASTM D-4385 Levels III and IV.

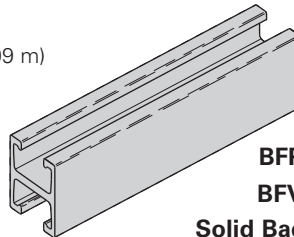

**BFP42A  
BFV42A  
Solid Back to Back**

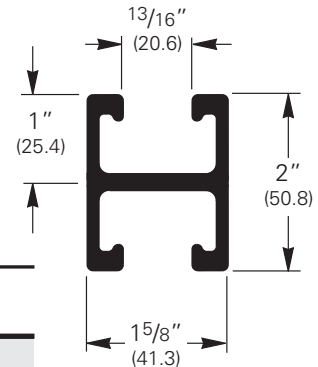

Part No.	Material	Description	Color	Weight	
				Lbs./ft.	kg/m
<b>BFP42A*</b>	Polyester Resin	Back To Back	Gray	.85	(1.26)
<b>BFV42A*</b>	Vinyl Ester Resin	Back To Back	Beige	.85	(1.26)

\* Insert -10 for 10'-0" (3.05 m) length or -20 for 20'-0" (6.09 m) length

Published design loads on page 187 are based on usage at 70°F (21°C) and must be reduced for continuous exposure to higher temperatures. Refer to the chart below for high temperature applications.

Temperature	Design Load Multiplier
75°F (24°C)	100%
100°F (38°C)	90%
125°F (52°C)	78%
150°F (66°C)	68%
175°F (79°C)	60%
200°F (93°C)	52%

## Field Cutting Sealant Kits

**RSK010** Pint Sealing Kit (473 cm<sup>3</sup>) includes sealant and brush applicator

- Seals exposed fibers after field cutting.
- UV resistant

APPROPRIATE PROTECTIVE CLOTHING AND RESPIRATORY PROTECTION DEVICE SHOULD BE WORN WHEN FIELD CUTTING OR GRINDING FIBERGLASS.

Reference page 183 for general fitting specifications.

## Beam Loading Data for Glass Reinforced Polyester Resin

Beam Span		Part No.	Maximum Allowable Beam Load		Deflection @ Maximum Allowable Beam Load		Allowable Load @ Deflection =				
			Lbs.	kN	in.	mm	1/240 Span		1/360 Span		
in.	mm							Lbs.	kN	Lbs.	kN
12"	(305)	<b>BFP42</b>	841	(3.74)	0.104	(2.64)	403	(1.79)	269	(1.19)	
		<b>BFP42A</b>	2325	(10.34)	0.060	(1.52)	1948	(8.66)	1299	(5.78)	
24"	(609)	<b>BFP42</b>	420	(1.87)	0.417	(10.59)	100	(0.44)	66	(0.29)	
		<b>BFP42A</b>	1161	(5.16)	0.239	(6.07)	486	(2.16)	323	(1.43)	
36"	(914)	<b>BFP42</b>	279	(1.24)	0.938	(23.82)	43	(0.19)	29	(0.13)	
		<b>BFP42A</b>	773	(3.44)	0.537	(13.64)	214	(0.95)	142	(0.63)	
48"	(1219)	<b>BFP42</b>	208	(0.92)	1.667	(42.34)	23	(0.10)	15	(0.06)	
		<b>BFP42A</b>	578	(2.57)	0.955	(24.26)	119	(0.53)	78	(0.34)	
60"	(1524)	<b>BFP42</b>	166	(0.74)	2.604	(66.14)	14	(0.06)	8	(0.03)	
		<b>BFP42A</b>	461	(2.05)	1.491	(37.87)	74	(0.33)	48	(0.21)	
72"	(1829)	<b>BFP42</b>	137	(0.61)	3.750	(95.25)	8	(0.03)	5	(0.02)	
		<b>BFP42A</b>	383	(1.70)	2.148	(54.56)	49	(0.22)	31	(0.14)	
96"	(2438)	<b>BFP42</b>	101	(0.45)	6.667	(169.34)	3	(0.01)	–	–	
		<b>BFP42A</b>	284	(1.26)	3.818	(96.98)	24	(0.10)	14	(0.04)	
120"	(3048)	<b>BFP42</b>	79	(0.35)	10.417	(264.59)	–	–	–	–	
		<b>BFP42A</b>	224	(0.99)	5.966	(151.53)	11	(0.05)	5	(0.02)	

## Beam Loading Data for Glass Reinforced Vinyl Ester Resin

Beam Span		Part No.	Maximum Allowable Beam Load		Deflection @ Maximum Allowable Beam Load		Allowable Load @ Deflection =				
			Lbs.	kN	in.	mm	1/240 Span		1/360 Span		
in.	mm							Lbs.	kN	Lbs.	kN
12"	(305)	<b>BFV42</b>	988	(4.39)	0.112	(2.84)	440	(1.96)	293	(1.30)	
		<b>BFV42A</b>	2865	(12.74)	0.063	(1.60)	2278	(10.13)	1518	(6.75)	
24"	(609)	<b>BFV42</b>	493	(2.19)	0.448	(11.38)	109	(0.48)	73	(0.32)	
		<b>BFV42A</b>	1431	(6.36)	0.252	(6.40)	568	(2.52)	378	(1.68)	
36"	(914)	<b>BFV42</b>	328	(1.46)	1.009	(25.63)	48	(0.21)	31	(0.14)	
		<b>BFV42A</b>	953	(4.24)	0.566	(14.37)	251	(1.11)	166	(0.74)	
48"	(1219)	<b>BFV42</b>	245	(1.09)	1.793	(45.54)	26	(0.11)	16	(0.07)	
		<b>BFV42A</b>	713	(3.17)	1.006	(25.55)	139	(0.62)	92	(0.41)	
60"	(1524)	<b>BFV42</b>	195	(0.87)	2.802	(71.17)	15	(0.06)	9	(0.04)	
		<b>BFV42A</b>	569	(2.53)	1.572	(39.93)	87	(0.38)	57	(0.25)	
72"	(1829)	<b>BFV42</b>	162	(0.72)	4.035	(102.49)	9	(0.04)	5	(0.02)	
		<b>BFV42A</b>	473	(2.10)	2.264	(57.50)	58	(0.26)	37	(0.16)	
96"	(2438)	<b>BFV42</b>	120	(0.53)	7.173	(182.19)	3	(0.01)	1	(0.004)	
		<b>BFV42A</b>	351	(1.56)	4.025	(102.23)	29	(0.13)	17	(0.07)	
120"	(3048)	<b>BFV42</b>	94	(0.42)	11.207	(284.66)	–	–	–	–	
		<b>BFV42A</b>	278	(1.23)	6.288	(159.71)	14	(0.06)	7	(0.03)	

### Loading Information

#### Beam Loads:

The above charts list the total allowable uniform load for various simple spans based on a minimum safety factor of 2. If the load is concentrated at center span, multiply the load from the above charts by 0.5 and the corresponding deflection by 0.8. All beams should be supported in a manner to prevent rotation at supports. Long, deep beams should be tied between supports to prevent twist. For channels with holes or slots use 90% of recommended load shown in channel loading chart.

Reference page 183 for general fitting specifications.

# Fiberglass

## BF\*22I Concrete Inserts

- Design Load 300 Lbs (1.47 kN)
- Safety Factor of 3
- Standard lengths: 6" (152), 12" (305), 24" (609), 36" (914), 48" (1219), 60" (1524), 72" (1829), 84" (2133), 96" (2438), 108" (2743) and 120" (3048)
- Available Material:
  - \*Insert P for BFP - Polyester Resin channel and tee
  - \*Insert V for BFV - Vinyl Ester Resin channel with Polyester Resin tee
- Shipped with removable styrofoam insert

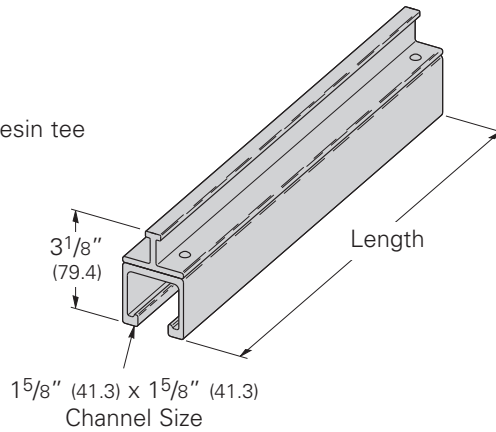

## Field Cutting Sealant Kits

**RSK010** ... Pint Sealing Kit (473 cm<sup>3</sup>)  
includes sealant and brush applicator

- Seals exposed fibers after field cutting •
  - UV resistant •

## BFV501 Series U-Bolts with Hex Nuts

- Design Load Safety Factor of 3
- Load A: Straight down loading
- Load B: Side loading
- Inner surface of U-Bolt is flat to provide additional contact surface area
- Material: Glass Reinforced Polyurethane

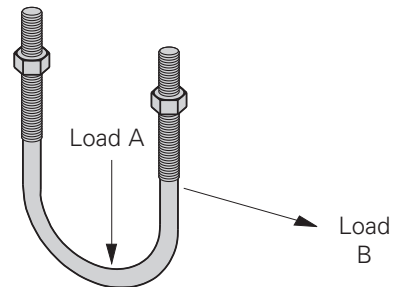

Part No.	Nominal Pipe Size		Thread Size	Design Load A		Design Load B		Maximum Torque		Wt./C	
	in.	mm		Lbs.	kN	Lbs.	kN	in.-Lbs.	N•m	Lbs.	kg
BFV501-1/2	1/2	(15)	3/8"-16	300	(1.33)	150	(.67)	30	(3.4)	3.5	(1.59)
BFV501-3/4	3/4	(20)	3/8"-16	300	(1.33)	150	(.67)	30	(3.4)	3.9	(1.77)
BFV501-1	1	(25)	3/8"-16	300	(1.33)	150	(.67)	30	(3.4)	4.4	(1.99)
BFV501-1 1/4	1 1/4	(32)	3/8"-16	300	(1.33)	150	(.67)	30	(3.4)	4.8	(2.18)
BFV501-1 1/2	1 1/2	(40)	3/8"-16	300	(1.33)	150	(.67)	30	(3.4)	5.2	(2.36)
BFV501-2	2	(50)	1/2"-13	600	(2.67)	200	(.89)	60	(6.8)	7.7	(3.49)
BFV501-2 1/2	2 1/2	(65)	1/2"-13	600	(2.67)	200	(.89)	60	(6.8)	10.2	(4.63)
BFV501-3	3	(80)	1/2"-13	600	(2.67)	200	(.89)	60	(6.8)	12.6	(5.71)
BFV501-3 1/2	3 1/2	(90)	1/2"-13	600	(2.67)	200	(.89)	60	(6.8)	15.1	(6.85)
BFV501-4	4	(100)	1/2"-13	600	(2.67)	200	(.89)	60	(6.8)	17.6	(7.98)

Reference page 183 for general fitting specifications.

## Channel Nuts

- Design Load Safety Factor of 3
- Overall Nut Height  $\frac{5}{8}$ " (15.9)
- Maximum torque and slip resistance loads shown are when using stainless steel bolts. When using fiberglass hardware use Max. Torque for fiberglass bolts, and multiply slip resistance loads by .14 for  $\frac{3}{8}$ "-16 and .60 for  $\frac{1}{2}$ "-13 thread size.
- Material: Glass Reinforced Polyurethane
- Spring Material: Zinc Plated Steel

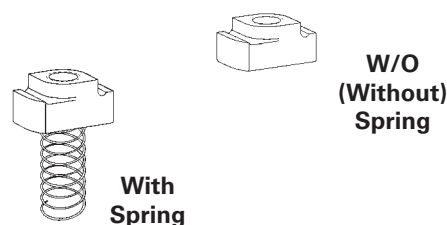

Part No.		Thread Size	Pull-Out		Slip Resistance		Max. Torque		Wt./C	
With Spring	W/O Spring		Lbs	kN	Lbs.	N	in.-Lbs.	N•m	Lbs.	kg
<b>BFV-224</b>	<b>BFV-224WO</b>	$\frac{1}{4}$ "-20	300	(1.33)	150	(.67)	200	(22.6)	2.4	(1.09)
<b>BFV-223</b>	<b>BFV-223WO</b>	$\frac{5}{16}$ "-18	300	(1.33)	150	(.67)	200	(22.6)	2.5	(1.13)
<b>BFV-228</b>	<b>BFV-228WO</b>	$\frac{3}{8}$ "-16	300	(1.33)	150	(.67)	200	(22.6)	2.3	(1.04)
<b>BFV-225</b>	<b>BFV-225WO</b>	$\frac{1}{2}$ "-13	300	(1.33)	150	(.67)	200	(22.6)	2.1	(0.95)

## BFVHHCS Hex Head Cap Screws

- Design Load Safety Factor of 3
- Material: Glass Reinforced Polyurethane

Part No.	Thread Size	Design Load (in tension)		Max. Torque		Wt./C	
		Lbs.	kN	in.-Lbs.	N•m	Lbs.	kg
<b>BFVHHCS <math>\frac{5}{16}</math> x 1</b>	$\frac{5}{16}$ "-18	190	(.84)	30	(3.4)	.4	(.18)
<b>BFVHHCS <math>\frac{5}{16}</math> x 1<math>\frac{1}{4}</math></b>	$\frac{5}{16}$ "-18	190	(.84)	30	(3.4)	.5	(.23)
<b>BFVHHCS <math>\frac{5}{16}</math> x 1<math>\frac{1}{2}</math></b>	$\frac{5}{16}$ "-18	190	(.84)	30	(3.4)	.6	(.27)
<b>BFVHHCS <math>\frac{5}{16}</math> x 2</b>	$\frac{5}{16}$ "-18	190	(.84)	30	(3.4)	.8	(.36)
<b>BFVHHCS <math>\frac{3}{8}</math> x 1</b>	$\frac{3}{8}$ "-16	300	(1.33)	45	(5.1)	.9	(.41)
<b>BFVHHCS <math>\frac{3}{8}</math> x 1<math>\frac{1}{4}</math></b>	$\frac{3}{8}$ "-16	300	(1.33)	45	(5.1)	1.1	(.50)
<b>BFVHHCS <math>\frac{3}{8}</math> x 1<math>\frac{1}{2}</math></b>	$\frac{3}{8}$ "-16	300	(1.33)	45	(5.1)	1.3	(.59)
<b>BFVHHCS <math>\frac{3}{8}</math> x 2</b>	$\frac{3}{8}$ "-16	300	(1.33)	45	(5.1)	1.3	(.59)
<b>BFVHHCS <math>\frac{3}{8}</math> x 2<math>\frac{1}{2}</math></b>	$\frac{3}{8}$ "-16	300	(1.33)	45	(5.1)	1.5	(.68)
<b>BFVHHCS <math>\frac{1}{2}</math> x 1</b>	$\frac{1}{2}$ "-13	490	(2.18)	110	(12.4)	1.4	(.63)
<b>BFVHHCS <math>\frac{1}{2}</math> x 1<math>\frac{1}{4}</math></b>	$\frac{1}{2}$ "-13	490	(2.18)	110	(12.4)	1.8	(.81)
<b>BFVHHCS <math>\frac{1}{2}</math> x 1<math>\frac{1}{2}</math></b>	$\frac{1}{2}$ "-13	490	(2.18)	110	(12.4)	2.2	(1.00)
<b>BFVHHCS <math>\frac{1}{2}</math> x 2</b>	$\frac{1}{2}$ "-13	490	(2.18)	110	(12.4)	3.0	(1.36)
<b>BFVHHCS <math>\frac{1}{2}</math> x 2<math>\frac{1}{2}</math></b>	$\frac{1}{2}$ "-13	490	(2.18)	110	(12.4)	3.7	(1.68)
<b>BFVHHCS <math>\frac{1}{2}</math> x 3</b>	$\frac{1}{2}$ "-13	490	(2.18)	110	(12.4)	4.5	(2.04)

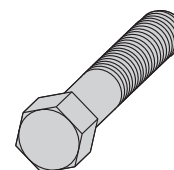

## BFVHN Hex Nuts

- $\frac{3}{4}$ " & 1" sizes are available. Contact inside sales for details
- Material: Glass Reinforced Polyurethane

Part No.	Thread Size	Nut Thickness		Wt./C	
		in.	mm	Lbs.	kg
<b>BFVHN <math>\frac{5}{16}</math></b>	$\frac{5}{16}$ "-18	$\frac{17}{64}$	(6.7)	.2	(.09)
<b>BFVHN <math>\frac{3}{8}</math></b>	$\frac{3}{8}$ "-16	$\frac{21}{64}$	(8.3)	.3	(.13)
<b>BFVHN <math>\frac{1}{2}</math></b>	$\frac{1}{2}$ "-13	$\frac{7}{16}$	(11.1)	.7	(.32)
<b>BFVHN <math>\frac{5}{8}</math></b>	$\frac{5}{8}$ "-11	$\frac{35}{64}$	(13.9)	1.4	(.63)

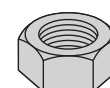

Reference page 183 for general fitting specifications.



# Fiberglass

## BFVATR All Threaded Rod

- Design Load Safety Factor of 3
- Use ATR nuts in place of hex nuts with 3/8"-16 and 1/2"-13 threaded rod in order to obtain minimum required thread engagement of 17/32" (13.5) to obtain design load shown below.
- Material: Glass Reinforced Vinyl Ester

Part No.	Thread Size	Design Load (in tension)		Max. Torque		Wt./Ft.	
		Lbs.	kN	in.-Lbs.	N•m	Lbs.	kg
BFVATR 3/8 x 48"	3/8"-16	425	(1.89)	45	(5.1)	.08	(.04)
BFVATR 1/2 x 48"	1/2"-13	750	(3.33)	110	(12.4)	.13	(.06)
BFVATR 5/8 x 48"	5/8"-11	950	(4.22)	230	(26.0)	.21	(.09)

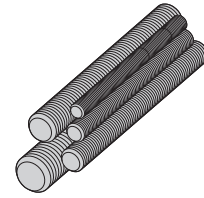

## BFVATRHN Threaded Rod Nuts

- ATR Nut is required with 3/8"-16 and 1/2"-13 ATR to provide additional thread engagement which is critical to ATR load carrying capacity.
- Material: Glass Reinforced Polyurethane

Part No.	Thread Size	H		Wt./C	
		in.	mm	Lbs.	kg
BFVATRHN 3/8	3/8"-16	3/4	(19)	.8	(.36)
BFVATRHN 1/2	1/2"-13	7/8	(22)	1.7	(.77)

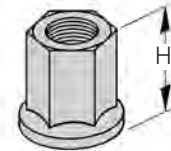

## BFVFW Flat Washers

- Material: PVC

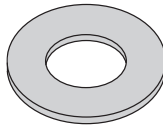

Part No.	Hole Size in.	Wt./C	
		Lbs.	kg
BFVFW 3/8	3/8	.5	(.22)
BFVFW 1/2	1/2	.5	(.22)
BFVFW 5/8	5/8	.5	(.22)
BFVFW 3/4	3/4	.5	(.22)
BFVFW 1	1	.5	(.22)

## BFV655 Series Rod Couplings

- Material: Glass Reinforced Polyurethane



Part No.	Thread Size	Wt./C	
		Lbs.	kg
BFV655-3/8	3/8"-16	7.4	(3.35)
BFV655-1/2	1/2"-13	11.3	(5.12)
BFV655-5/8	5/8"-11	16.7	(7.57)

## BFVSL Series Stop-Lock Kits

- Material: Glass Reinforced Polyurethane

Part No.	Thread Size	Wt./C	
		Lbs.	kg
BFVSL-3/8	3/8"-16	7.4	(3.35)
BFVSL-1/2	1/2"-13	11.3	(5.12)

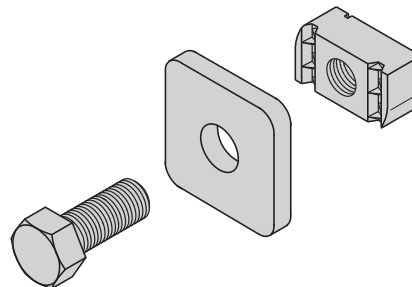

Reference page 183 for general fitting specifications.

## BFV100 thru BFV300 Adjustable Pipe Clamps

- Completely Non-Metallic
- Adjustable to U.S. & Metric Pipe Diameters
- Fits OD Sizes 3/4" (19.0) to 3 1/2" (88.9)
- Easy To Install
- No Special Tools Required
- Design Load Safety Factor of 3
- Material: Glass Reinforced Polyurethane
- Not recommended for vertical installation without additional Stop-Lock Kit. Kit includes one square washer, channel nut and hex head cap screw.

Order (Stop-Lock Kit on page 191) BFVSL-3/8 for 3/8"-16 hardware or BFVSL-1/2 for 1/2"-13 hardware.

Mount kit below clamp when used in vertical strut to prevent clamp slipping.

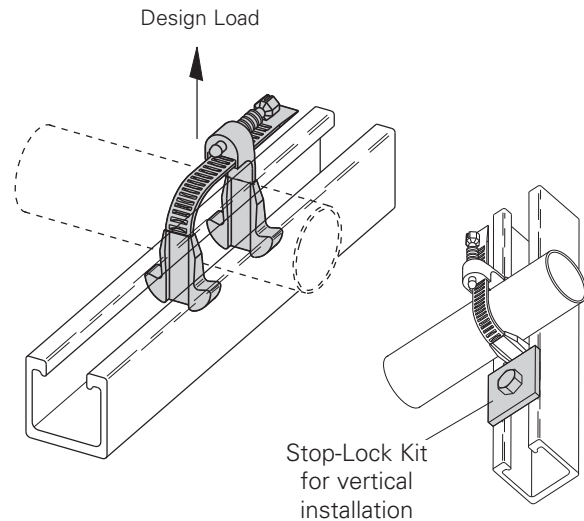

Part No.	Nominal Pipe Sizes		Pipe O.D. Range		Design Load		Max. Torque	
	in.	mm	in.	mm	Lbs.	kN	in.-Lbs.	N*m
<b>BFV100</b>	1/2 - 1 1/2	(15 - 40)	.75 - 1.90	(21.3 - 48.3)	135	(.60)	10	(1.13)
<b>BFV200</b>	1 1/2 - 2	(40 - 51)	1.90 - 2.37	(48.3 - 60.3)	135	(.60)	36	(4.07)
<b>BFV300</b>	2 1/2 - 3	(63 - 76)	2.87 - 3.50	(73.0 - 88.9)	145	(.64)	36	(4.07)

## BFV2000 Series Non-Metallic Pipe Clamps

- For rigid and PVC conduit.
- Standard hardware includes slotted round head machine screw and square nut in 316 stainless steel
- Design Load Safety Factor of 3
- Material: Glass Reinforced PPO
- Not recommended for vertical installation without additional Stop-Lock Kit. Kit includes one square washer, channel nut and hex head cap screw. Order (Stop-Lock Kit on page 191) BFVSL-3/8 for 3/8"-16 hardware or BFVSL-1/2 for 1/2"-13 hardware. Mount kit below clamp when used in vertical strut to prevent clamp slipping.
- If non-metallic hardware is required, add N to the part number.

**Example: BFV2008N**

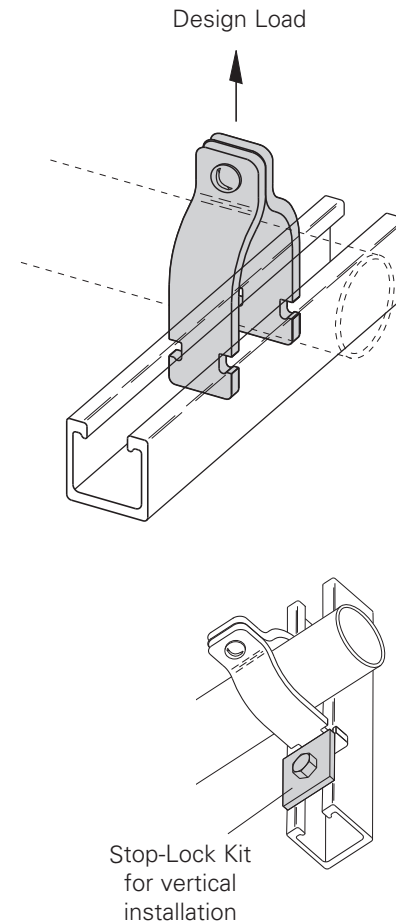

Part No.	Nominal Pipe Size		Design Load		Maximum Torque	
	in.	mm	Lbs.	kN	in.-Lbs.	N*m
<b>BFV2008</b>	1/2	(15)	300	(1.33)	10	(1.13)
<b>BFV2009</b>	3/4	(20)	300	(1.33)	10	(1.13)
<b>BFV2010</b>	1	(25)	300	(1.33)	10	(1.13)
<b>BFV2011</b>	1 1/4	(32)	300	(1.33)	10	(1.13)
<b>BFV2012</b>	1 1/2	(40)	300	(1.33)	10	(1.13)
<b>BFV2013</b>	2	(50)	300	(1.33)	10	(1.13)
<b>BFV2014</b>	2 1/2	(65)	300	(1.33)	10	(1.13)
<b>BFV2015</b>	3	(80)	300	(1.33)	10	(1.13)
<b>BFV2016</b>	3 1/2	(90)	300	(1.33)	10	(1.13)
<b>BFV2017</b>	4	(100)	300	(1.33)	10	(1.13)

Reference page 183 for general fitting specifications.

# Fiberglass

## BFP2400 Series 2-Hole Pipe Clamps

- Design Load Safety Factor of 3
- Material: Glass Reinforced Polyester

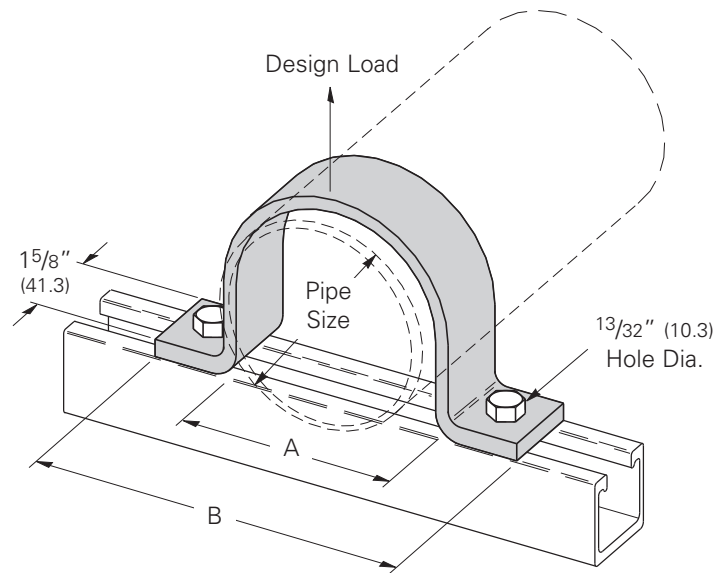

Part No.	Nominal Pipe Size		A		B		Design Load	
	in.	mm	in.	mm	in.	mm	Lbs.	kN
BFP2400-2	2	(50)	2 <sup>3</sup> / <sub>8</sub>	(60)	5 <sup>1</sup> / <sub>2</sub>	(140)	115	(0.51)
BFP2400-3	3	(80)	3 <sup>1</sup> / <sub>2</sub>	(89)	6 <sup>3</sup> / <sub>4</sub>	(171)	130	(0.58)
BFP2400-4	4	(100)	4 <sup>1</sup> / <sub>2</sub>	(114)	7 <sup>3</sup> / <sub>4</sub>	(197)	150	(0.66)
BFP2400-6	6	(150)	6 <sup>5</sup> / <sub>8</sub>	(168)	10	(254)	150	(0.66)

## BFV751 & BFV751J Beam Clamp

- Design Load Safety Factor of 3
- BFV751J (clip included) must be used when installed on tapered flange beams.
- Material: Glass Reinforced Polyurethane
- Setscrew material: Stainless Steel 316 ASTM F593 Group 2, S4

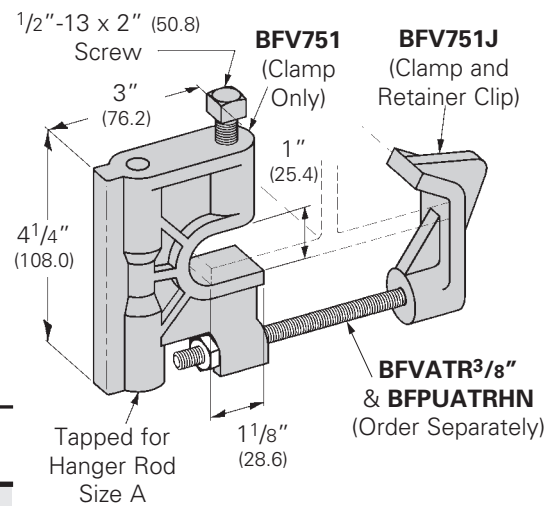

Part No.	For Hanger Rod Size A	Design Load		Torque	
		Lbs.	kN	ft.-Lbs.	N•m
BFV751-3/8	3/8"-16	500	(2.22)	10	(13)
BFV751J-3/8	3/8"-16	500	(2.22)	10	(13)
BFV751-1/2	1/2"-13	500	(2.22)	10	(13)
BFV751J-1/2	1/2"-13	500	(2.22)	10	(13)
BFV751-5/8	5/8"-11	500	(2.22)	10	(13)
BFV751J-5/8	5/8"-11	500	(2.22)	10	(13)

Reference page 183 for general fitting specifications.

## BFV755 Beam Clamp

- Design Load Safety Factor of 3
- Material: Glass Reinforced Polyurethane
- Setscrew material: Stainless Steel 316 ASTM F593 Group 2, S4

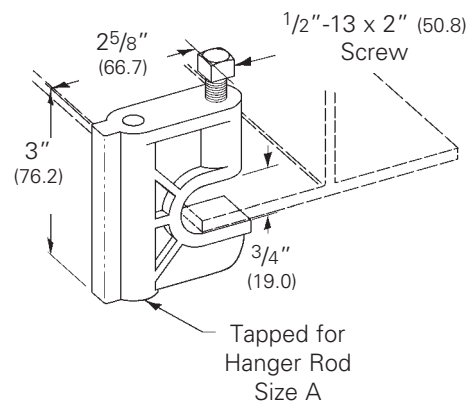

Part No.	For Hanger Rod Size A	Design Load		Torque	
		Lbs.	kN	ft.-Lbs.	N•m
BFV755-3/8	3/8"-16	400	(1.78)	10	(13)
BFV755-1/2	1/2"-13	400	(1.78)	10	(13)

## BFV3104 Series Clevis Hangers

- Design Load Safety Factor of 3 at 120°F (49°C).
- Insulation may be required at higher temperatures.
- Order hanger rod and nuts separately.
- Material: Glass Reinforced Polyurethane For BFV3104-1 thru BFV3104-6
- Material: Glass Reinforced Polyester & Vinyl Ester For BFV3104-8 thru BFV3104-12

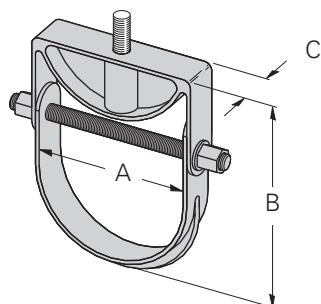

BFV3104-1 thru BFV3104-6

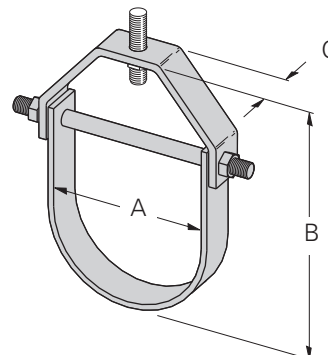

BFV3104-8 thru BFV3104-12

Part No.	Nominal Pipe Size		A		B		C		Hanger Rod Size	Design Load	
	in.	mm	in.	mm	in.	mm	in.	mm		Lbs.	kN
BFV3104-1	1	(50)	1 1/2	(38)	4 1/4	(108)	1 1/4	(32)	1/2"-13	670	(2.98)
BFV3104-1 1/2	1 1/2	(65)	2	(51)	5 1/8	(130)	1 1/4	(32)	1/2"-13	670	(2.98)
BFV3104-2	2	(50)	2 1/2	(63)	6 1/2	(165)	1 1/4	(32)	1/2"-13	730	(3.25)
BFV3104-2 1/2, 3, 4	2 1/2-4	(65-100)	5 1/8	(130)	10	(254)	1 1/2	(38)	1/2"-13	1150	(5.11)
BFV3104-6	6	(150)	6 3/4	(171)	12 5/16	(313)	2	(51)	1/2"-13	1170	(5.20)

Part No.	Nominal Pipe Size		A		B		C		Hanger Rod Size	Design Load	
	in.	mm	in.	mm	in.	mm	in.	mm		Lbs.	kN
BF*3104-8	8	(200)	9 1/4	(235)	16 5/8	(422)	3	(76)	5/8"-11	350	(1.55)
BF*3104-10	10	(250)	11 3/8	(289)	19 7/8	(505)	4	(101)	5/8"-11	450	(2.01)
BF*3104-12	12	(300)	13 1/2	(343)	22 3/8	(568)	5	(127)	5/8"-11	600	(2.69)

\*Specify P for polyester or V for Vinyl ester.

Reference page 183 for general fitting specifications.

# Fiberglass

## BF\*409 Series Brackets 6" (152mm) to 24" (609mm) Long

- Design Load Safety Factor of 3 based on uniform loading
- MH1 - From Top of Bracket to center of Mounting Hole
- MH2 - From Bottom of Bracket to center of Mounting Hole

Part No.	A		Design Load	
	in.	mm	Lbs.	kN
BF*409-6	10	(250)	1400	(6.22)
BF*409-9	13	(330)	1000	(4.45)
BF*409-12	16	(406)	800	(3.56)
BF*409-18	22	(559)	675	(3.00)
BF*409-24	28	(711)	450	(2.00)

\* Insert P for Glass Reinforced Polyester Resin or V for Glass Reinforced Vinyl Ester Resin

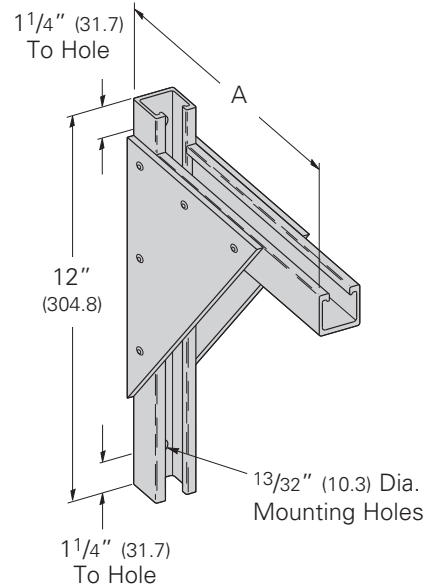

## BF\*494 Series Brackets 24" (609mm) to 36" (914mm) Long

- Design Load Safety Factor of 3 based on uniform loading
- MH1 - From Top of Bracket to center of Mounting Hole
- MH2 - From Bottom of Bracket to center of Mounting Hole
- Material: Glass Reinforced Vinyl Ester or Polyester

Part No.	A		B		Design Load	
	in.	mm	in.	mm	Lbs.	kN
BF*494-24	28	(711)	23	(584)	750	(3.33)
BF*494-30	34	(863)	26	(660)	750	(3.33)
BF*494-36	40	(1016)	29	(736)	750	(3.33)

\* Insert P for Glass Reinforced Polyester Resin or V for Glass Reinforced Vinyl Ester Resin

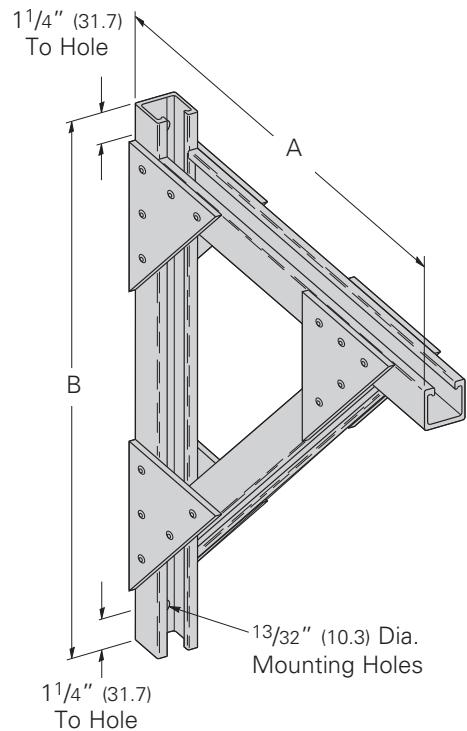

Reference page 183 for general fitting specifications.

**BFV201**  
**Square Washer for 3/8" bolt**

- Material: Injection Molded Glass Reinforced Polyurethane

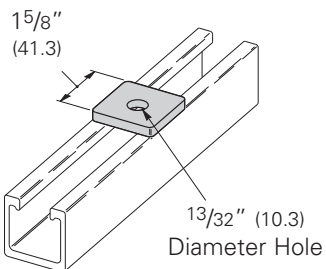

**BFV202**  
**Square Washer for 1/2" bolt**

- Material: Injection Molded Glass Reinforced Polyurethane

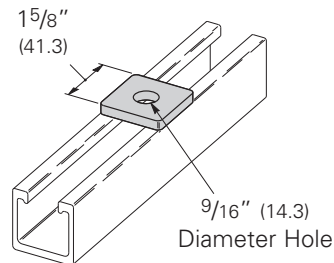

**BFV340**  
**Two Hole Flat Plate**

- Material: Injection Molded Glass Reinforced Polyurethane

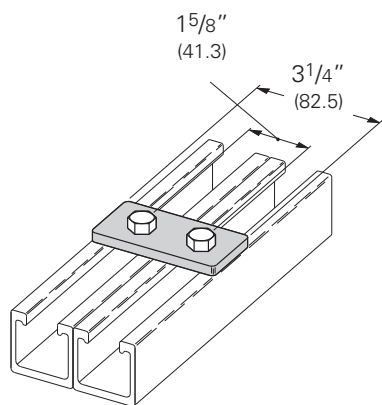

**BFV129**  
**Two Hole Splice Plate**

- Material: Injection Molded Glass Reinforced Polyurethane

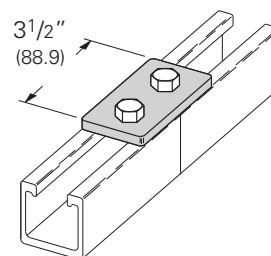

**BFV141**  
**Three Hole Flat Plate**

- Material: Injection Molded Glass Reinforced Polyurethane

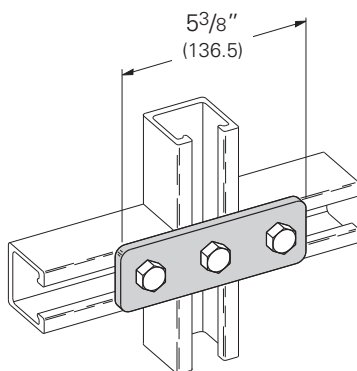

**BFV557**  
**Three Hole Flat Plate**

- Material: Injection Molded Glass Reinforced Polyurethane

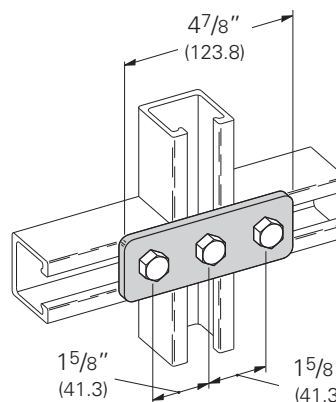

Reference page 183 for general fitting specifications.

# Fiberglass

## BFV341 Four Hole Splice Plate

- Material: Injection Molded Glass Reinforced Polyurethane

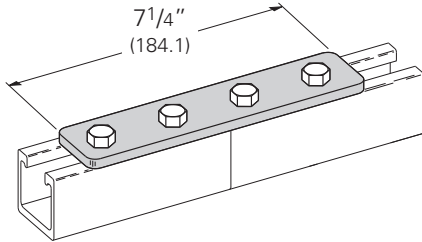

## BFV342 Five Hole Flat Plate

- Material: Injection Molded Glass Reinforced Polyurethane

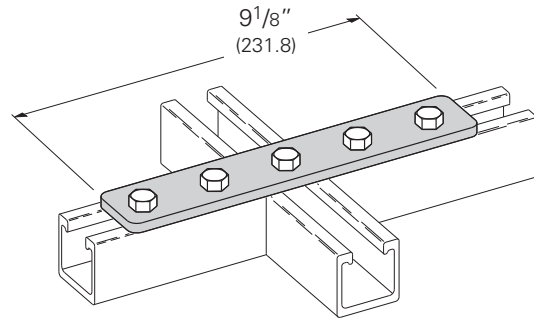

## BFV140 Three Hole Flat Corner Plate

- Material: Injection Molded Glass Reinforced Polyurethane

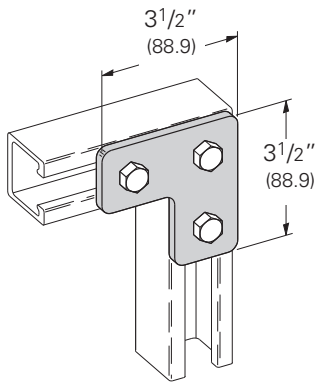

## BFV143 Four Hole Flat Corner Plate

- Material: Injection Molded Glass Reinforced Polyurethane

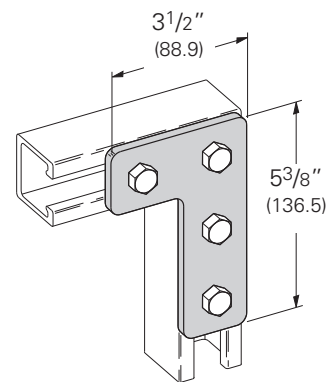

## BFV132 Five Hole Flat Cross Plate

- Material: Injection Molded Glass Reinforced Polyurethane

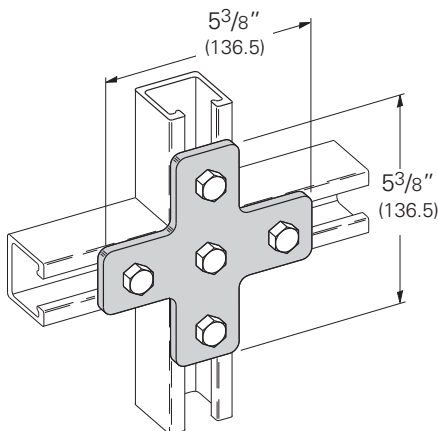

## BFV133 Four Hole Flat Tee Plate

- Material: Injection Molded Glass Reinforced Polyurethane

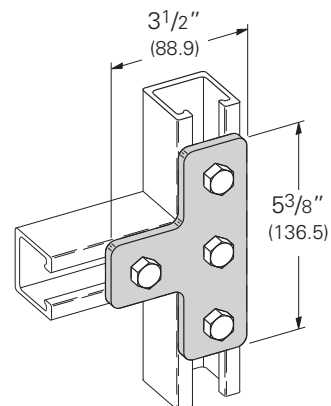

Reference page 183 for general fitting specifications.

**BFV135**  
**Three Hole Flat Gusset Corner Plate**

- Material: Injection Molding Glass Reinforced Polyurethane

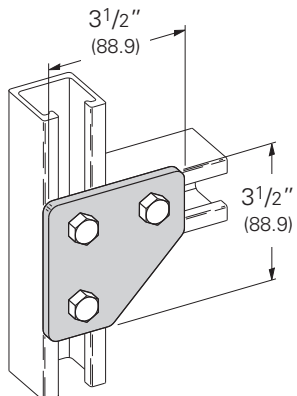

**BFV142**  
**Four Hole Flat Gusset Corner Plate**

- Material: Injection Molding Glass Reinforced Polyurethane

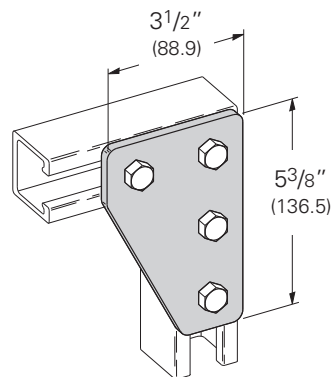

**BFV337**  
**Three Hole Flat Gusset Tee Plate**

- Material: Injection Molding Glass Reinforced Polyurethane

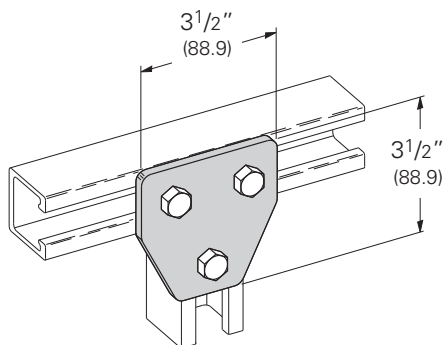

**BFV136**  
**Four Hole Flat Gusset Tee Plate**

- Material: Injection Molding Glass Reinforced Polyurethane

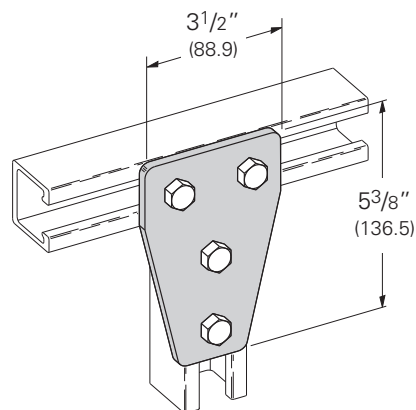

**BFV532**  
**Five Hole Flat Gusset Tee Plate**

- Material: Injection Molding Glass Reinforced Polyurethane

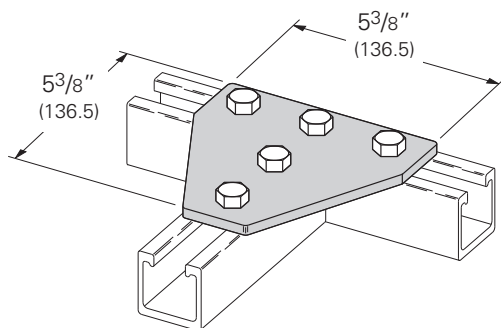

**BFV334**  
**Seven Hole Flat Gusset Cross Plate**

- Material: Injection Molding Glass Reinforced Polyurethane

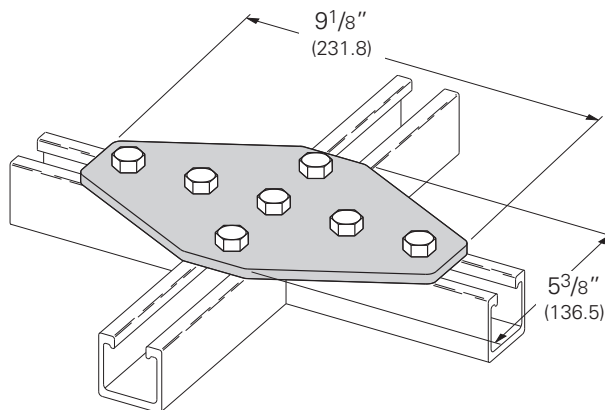

Reference page 183 for general fitting specifications.



# Fiberglass

## BFV101 Two Hole 90° Corner Angle

- Material: Injection Molded Glass Reinforced Polyurethane

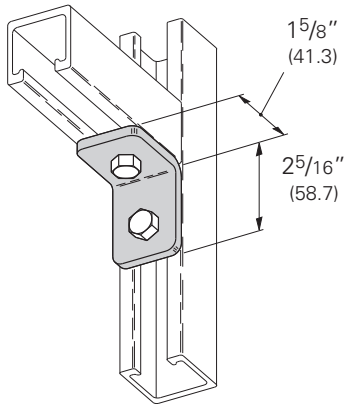

## BFV103 Three Hole 90° Corner Angle

- Material: Injection Molded Glass Reinforced Polyurethane

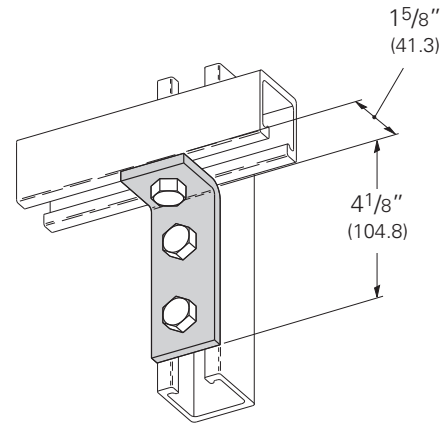

## BFV104 Four Hole 90° Corner Angle

- Material: Injection Molded Glass Reinforced Polyurethane

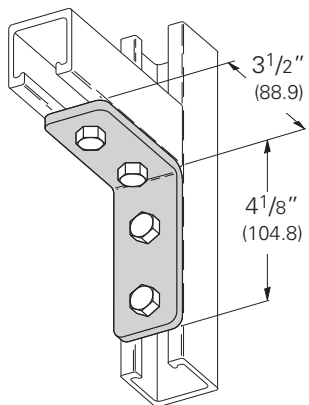

## BFV118 Four Hole 90° Gussetted Shelf Angle

- Material: Injection Molded Glass Reinforced Polyurethane

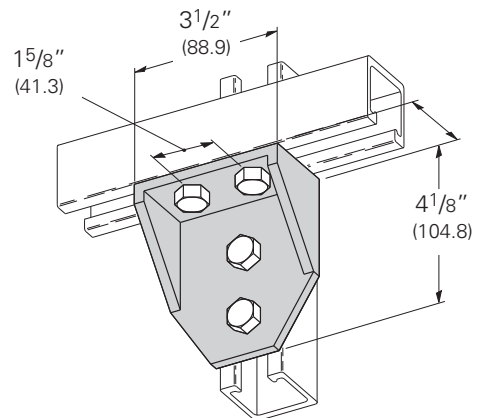

## BFV558 Four Hole 90° Corner Angle

- Material: Injection Molded Glass Reinforced Polyurethane

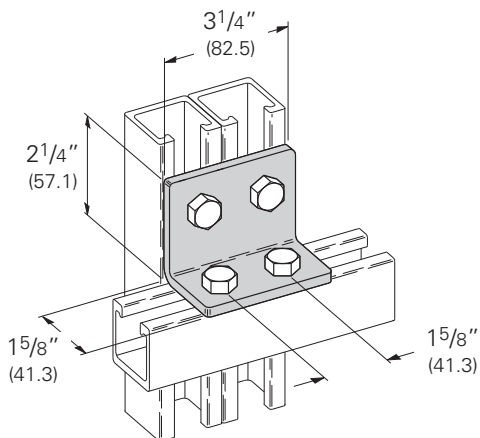

## BFV371-2G Three Hole 90° Gussetted Corner Angle

- Material: Injection Molded Glass Reinforced Polyurethane

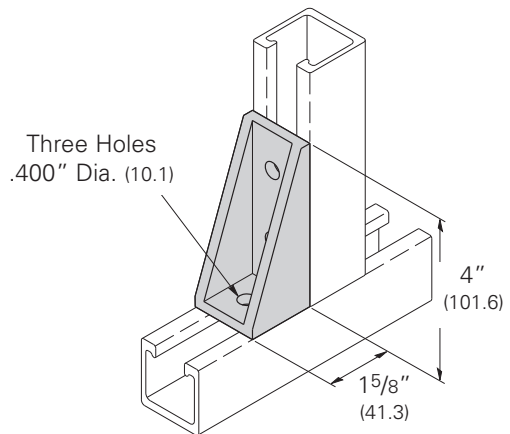

Reference page 183 for general fitting specifications.

## BFV280SQ Post Base for BF\*22

- Material: Glass Reinforced Polyurethane

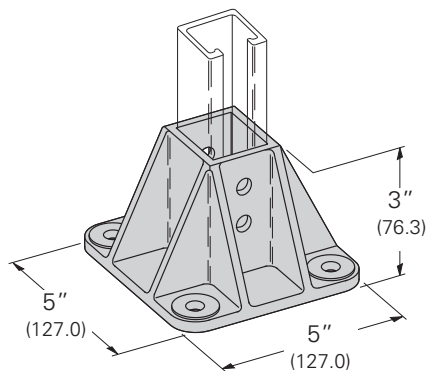

## BFV281SQ Post Base for BF\*22A

- Material: Glass Reinforced Polyurethane

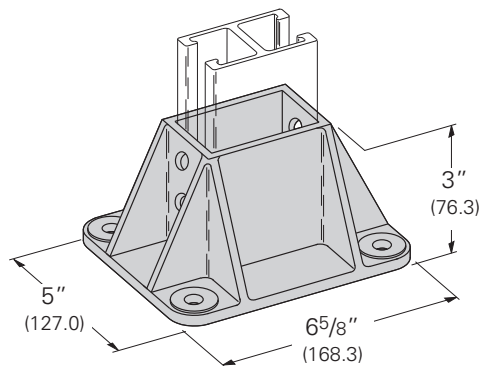

## BFV650 Channel Spacer

- Spacer I.D. accommodates 3/8" rod or bolts.
- Material: Polyurethane

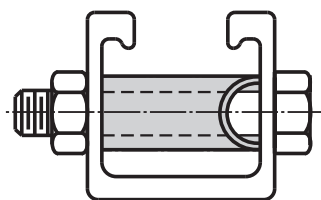
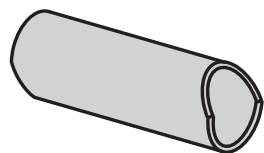

Used when attaching fittings to side walls of channel. This channel spacer prevents wall compression in heavy load conditions.

## B217P Plastic Closure Strip

- Available in 10 Ft. (3.05 m) lengths.
- Material: PVC

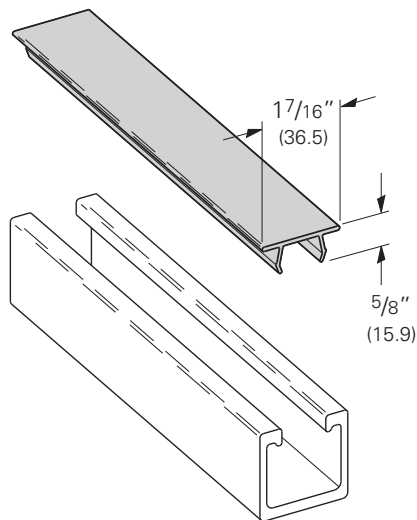

Reference page 183 for general fitting specifications.