



*Think Automation and beyond...*





**ø30mm  
Switches & Pilot Lights**





---











IDEC CORPORATION

# ø30 ø30 series Switches & Pilot Lights (Selection Guide)









Function	XN Series Emergency Stop Switch				HN Series Emergency Stop Switch
Category	Plastic Bezel		Flush Bezel	Padlockable	–
	Pushlock Pull/Turn Reset		Pushlock Pull/Turn Reset	Pushlock Turn Reset	Pushlock Turn Reset
Shape		 ø60mm Mushroom			
Model	XN1E-BV4 XN1E-LV4 XN1E-TV4	XN1E-BV5	XN5E-BV4 XN5E-LV4 XN5E-TV4	XN4E-BL4 XN4E-LL4 XN4E-TL4	HN1E-BV4 HN1E-LV4
Page	7		8	9	14











Function	Pushbutton							
Category	Flush		Extended		Extended with Half Shroud		Extended with Full Shroud	
	Momentary/Maintained							
Shape								
Model	ABN1 AON1	(Diecast) ABD1 AOD1	ABN2 AON2	(Diecast) ABD2 AOD2	ABN2G AON2G	(Diecast) ABGD2 AOGD2	ABN2F AON2F	(Diecast) ABFD2 AOFD2
Page	21	74	21	74	21	74	21	74







Function	Pushbutton									
Category	Mushroom		Mushroom with Full Shroud		Palm Mushroom		Jumbo Mushroom with Shallow Shroud		Jumbo Mushroom with Deep Shroud	
	Momentary/Maintained					Momentary				
Shape										
Model	ABN3 AON3	(Diecast) ABD3 AOD3	ABN3G AON3G	(Diecast) ABGD3 AOGD3	ABN4 AON4	(Diecast) ABD4 AOD4	ABN4G AON4G	(Diecast) ABGD4 AOGD4	ABN4F AON4F	(Diecast) ABFD4 AOFD4
Page	22	75	22	75	22	75	22	75	22	75

Function	Pushbutton				
Category	Mushroom Pushlock Turn Reset		Mushroom Push Turn Lock		Mushroom Pushlock Key Reset
Shape					
Model	AVN3	(Diecast) AVD3	AJN3	(Diecast) AJD3	ABN3K
Page	23	76	23	76	23

























# ø30 Series Switches & Pilot Lights (Selection Guide) ø30



Function	Pushbutton					
Category	Pin Lock	Mushroom Pull		Mushroom Push-Pull		Square Flush Momentary
Shape	 	 	 	 		
Model	(Diecast) ABD8P	ATN23	(Diecast) AZD3	ATN21 ATN22	(Diecast) AYD31	UBQN1
Page	76	24	76	24	76	22





















Function	Pushbutton			Twin Maintained Pushbutton	
Category	Square Extended Momentary	Square Twin Momentary	Square Twin Maintained	Flush Twin Maintained	Mushroom Twin Maintained
Shape	 	 	 	 	 
Model	UBQN2	UWQN1	UWQN2	ABBN11	ABBN33
Page	22	25	25	25	25

Function	Pilot Light (LED)		
Category	Dome	Square	Rectangular (Marking)
Shape	 	 	 
Model	APN1 APNE1	(Diecast) APD1 APDE1	UPQN3B
Page	26	77	27









# ø30 ø30 series Switches & Pilot Lights (Selection Guide)









Function	Illuminated Pushbutton (LED)									
Category	Extended		Extended with Half Shroud		Extended with Full Shroud		Mushroom		Mushroom Pushlock Turn Reset	
	Momentary/Maintained									
Shape	    		    		    		    		   	
Model	ALN2 ALNE2 AOLN2 AOLNE2	(Diecast) ALD2 AOLD2	ALGN2 ALGNE2 AOLGN2 AOLGNE2		ALFN2 ALFNE2 AOLFN2 AOLFNE2	(Diecast) ALFD2 AOLFD2	ALN3 ALNE3 AOLN3 AOLNE3	(Diecast) ALD3 AOLD3	AVLN3 AVLNE3	(Diecast) AVLD3 AVLDE3
Page	29	78	30		31	79	32	80	33	81

Function	Illuminated Pushbutton (LED)
Category	Mushroom Push Turn Lock
Shape	    
Model	AJLN3
Page	33

Function	Selector Switch						Illuminated Selector Switch	
Category	Knob		Lever		Key		Knob	
Shape	    		    		    		    	
Model	ASN ASTN	(Diecast) ASD	ASN□L ASTN□L	(Diecast) ASD□L	ASN□K ASTN□K	(Diecast) ASD□K	ASLN	(Diecast) ASLD
Page	34, 41	82	36, 42	83	38, 43	84	44	85

# ø30 Series Switches & Pilot Lights (Selection Guide) ø30

Function	Selector Pushbutton				Mono-Lever Switch	
Category	Ring		Lever		Standard	Interlocking
Shape	 		 		 	 
Model	ABN	(Diecast) ASBD2	ABN□L	(Diecast) ASBD2L	ARN ARNS	ARNL
Page	46	87	46	87	48	48

Function	Cam Switch			
Category	Knob	Key	Enclosed	Spring Return Enclosed
Shape	  (ACSNO only)	  (ACSNK only)	 	 
Model	ACSNO ACSSO	ACSNK ACSSK	UCSQO	UCSQM
Page	51	51	51	51

# ø30 XN Series Emergency Stop Switches

## ø30 mm, 4-contact Emergency Stop Switch. Padlockable and flush bezel are available.

- Padlockable, flush bezel, ø60mm jumbo mushroom, illuminated, LED push-on are available.
- IDEC's original "Safe break action" and reverse energy structure ensure the highest level of safety.
- Safety lock mechanism (IEC 60947-5-5, 6.2)
- Direct opening action mechanism (IEC 60947-5-5, 5.2, IEC60947-5-1, Annex K)
- Short depth behind the panel – only 47.7 mm for 4-contact, illuminated (flush bezel: 60.4 mm, padlockable: 61.4 mm)
- Padlockable can be locked using padlocks when latched (main contact: OFF). The rugged aluminum diecast shroud allows for installing a maximum of 20 padlocks using a hasp (total weight: 1500g maximum).
- Gold-plated silver contacts.
- Red (Munsell 5R4/12) or bright red (Munsell 7.5R4.5/14) colors are available.



## Standards

Applicable Standards	Mark	File No. or Organization
UL508 CSA C22.2 No. 14		UL/c-UL File No. E68961 (padlockable only)
IEC60947-5-5 UL991 NFPA79		UL Listing File No. E305148
EN60947-5-5		TÜV SÜD
		EU Low Voltage Directive
GB14048.5		CCC No. 2008010305290010

## Contact Ratings

### NC main contacts (black)/NO monitor contacts (blue)

Rated Insulation Voltage (Ui)		250V				
Rated Thermal Current (Ith)		5A				
Rated Operating Voltage (Ue)		30V	125V	250V		
Rated Operating Current	Main Contacts	AC 50/60 Hz	Resistive Load (AC-12)	–	5A	3A
			Inductive Load (AC-15)	–	3A	1.5A
	DC	Resistive Load (DC-12)	2A	0.4A	0.2A	
		Inductive Load (DC-13)	1A	0.22A	0.1A	
Monitor Contacts	AC 50/60 Hz	Resistive Load (AC-12)	–	1.2A	0.6A	
		Inductive Load (AC-14)	–	0.6A	0.3A	
	DC	Resistive Load (DC-12)	2A	0.4A	0.2A	
		Inductive Load (DC-13)	1A	0.22A	0.1A	
Contact Material		Gold-plated Silver				

- Minimum applicable load: 5V AC/DC, 1 mA (reference value) (May vary depending on the operating conditions and load types.)
- The rated operating currents are measured at resistive/inductive load types specified in IEC 60947-5-1.

## Illumination Ratings (LED)

Rated Voltage	Operating Voltage	Rated Current
24V AC/DC	24V AC/DC ±10%	15 mA





## Specifications

Applicable Standards	IEC60947-5-1, EN60947-5-1 IEC60947-5-5, EN60947-5-5 JIS C8201-5-1, UL508, UL991, NFPA79 CSA C22.2 No. 14, GB14048.5
Operating Temperature	Non-illuminated: –25 to +60°C (no freezing) Illuminated: –25 to +55°C (no freezing)
Storage Temperature	–45 to +80°C
Operating Humidity	45 to 85% RH (no condensation)
Minimum Force Required for Direct Opening Action	80N
Minimum Operator Stroke Required for Direct Opening Action	4.0 mm
Maximum Operator Stroke	4.5 mm
Contact Resistance	50 mΩ maximum (initial value)
Insulation Resistance	100 MΩ minimum (500V DC megger)
Overvoltage Category	II
Impulse Withstand Voltage	2.5 kV
Pollution Degree	3
Operating Frequency	900 operations/hour
Shock Resistance	Operating extremes: 150 m/s <sup>2</sup> Damage limits: 1000 m/s <sup>2</sup>
Vibration Resistance	Operating extremes: 10 to 500 Hz, amplitude 0.35 mm, acceleration 50 m/s <sup>2</sup> Damage limits: 10 to 500 Hz, amplitude 0.35 mm, acceleration 50 m/s <sup>2</sup>
Durability (at 900 operations/h, on-duration 40%)	Mechanical: 250,000 operations minimum Electrical: 100,000 operations minimum 250,000 operations minimum (24V AC/DC, 100 mA)
Degree of Protection	Operator: IP65 (IEC60529) Terminal: IP20 (when XW9Z-VL2MF is installed)
Short-circuit Protection	250V/10A fuse (Type aM, IEC60269-1/IEC60269-2)
Conditional Short-circuit Current	1000A
Terminal Style	M3 screw terminal
Recommended Tightening Torque for Terminal Screw	0.6 to 1.0 N·m
Recommended Tightening Torque for Locking Ring	2.5 N·m
Applicable Wire Size	0.75 to 1.25 mm <sup>2</sup> (AWG18 to 16)
Total Weight of a Hasp and Padlocks	1500g maximum (padlockable)
Reinforced Insulation (IEC 60664-1)	Between live part and metal bezel (flush bezel, padlockable)
Weight	83g (XN1E-LV404Q4MR) 93g (XN1E-BV504MR) 89g (XN5E-LV404Q4MR) 120g (XN4E-LL404Q4MR)

# XN series Emergency Stop Switches ø30



## Plastic Bezel

### Non-illuminated Pushlock Pull/Turn Reset (Solder Terminal)

Shape	NC Main Contact	NO Monitor Contact	Part No.		① Operator Color Code
			IP20 Fingersafe Terminal	w/Terminal Cover	
 	1NC	—	XN1E-BV401MF①	XN1E-BV401M①	R: Red RH: Bright red
	2NC	—	XN1E-BV402MF①	XN1E-BV402M①	
	3NC	—	XN1E-BV403MF①	XN1E-BV403M①	
	4NC	—	XN1E-BV404MF①	XN1E-BV404M①	
	1NC	1NO	XN1E-BV411MF①	XN1E-BV411M①	
	2NC	1NO	XN1E-BV412MF①	XN1E-BV412M①	
	3NC	1NO	XN1E-BV413MF①	XN1E-BV413M①	
	2NC	2NO	XN1E-BV422MF①	XN1E-BV422M①	
 	1NC	—	XN1E-BV501MF①	XN1E-BV501M①	
	2NC	—	XN1E-BV502MF①	XN1E-BV502M①	
	3NC	—	XN1E-BV503MF①	XN1E-BV503M①	
	4NC	—	XN1E-BV504MF①	XN1E-BV504M①	
	1NC	1NO	XN1E-BV511MF①	XN1E-BV511M①	
	2NC	1NO	XN1E-BV512MF①	XN1E-BV512M①	
	3NC	1NO	XN1E-BV513MF①	XN1E-BV513M①	
	2NC	2NO	XN1E-BV522MF①	XN1E-BV522M①	



- Specify a color code in place of ① in the Part No.
- Only solid wires can be used on the IP20 fingersafe terminal switches.

### Illuminated Pushlock Pull/Turn Reset (Solder Terminal)

Shape	Illumination	Rated Voltage	NC Main Contact	NO Monitor Contact	Part No.		Operator Color
					IP20 Fingersafe Terminal	w/Terminal Cover	
 	LED	24V AC/DC	1NC	—	XN1E-LV401Q4MFR	XN1E-LV401Q4MR	Red only
			2NC	—	XN1E-LV402Q4MFR	XN1E-LV402Q4MR	
			3NC	—	XN1E-LV403Q4MFR	XN1E-LV403Q4MR	
			4NC	—	XN1E-LV404Q4MFR	XN1E-LV404Q4MR	
			1NC	1NO	XN1E-LV411Q4MFR	XN1E-LV411Q4MR	
			2NC	1NO	XN1E-LV412Q4MFR	XN1E-LV412Q4MR	
			3NC	1NO	XN1E-LV413Q4MFR	XN1E-LV413Q4MR	
			2NC	2NO	XN1E-LV422Q4MFR	XN1E-LV422Q4MR	

- Only solid wires can be used on the IP20 fingersafe terminal switches.

### Illuminated Push-ON Pushlock Pull/Turn Reset (Solder Terminal)



Shape	Illumination	Rated Voltage	NC Main Contact	NO Monitor Contact	Part No.		Operator Color
					IP20 Fingersafe Terminal	w/Terminal Cover	
 	LED	24V AC/DC	2NC	—	XN1E-TV402Q4MFR	XN1E-TV402Q4MR	Red only
			3NC	—	XN1E-TV403Q4MFR	XN1E-TV403Q4MR	
			2NC	1NO	XN1E-TV412Q4MFR	XN1E-TV412Q4MR	

- Push-ON is illuminated when the operator is latched, and turns off when reset.
- Only solid wires can be used on the IP20 fingersafe terminal switches.

# ø30 XN Series Emergency Stop Switches



## Flush Bezel

### Non-illuminated Pushlock Pull/Turn Reset (Solder Terminal)

Shape	NC Main Contact	NO Monitor Contact	Part No.		Operator Color Code
			IP20 Fingersafe Terminal	w/Terminal Cover	
 	1NC	—	XN5E-BV401MF①	XN5E-BV401M①	R: Red RH: Bright red
	2NC	—	XN5E-BV402MF①	XN5E-BV402M①	
	3NC	—	XN5E-BV403MF①	XN5E-BV403M①	
	4NC	—	XN5E-BV404MF①	XN5E-BV404M①	
	1NC	1NO	XN5E-BV411MF①	XN5E-BV411M①	
	2NC	1NO	XN5E-BV412MF①	XN5E-BV412M①	
	3NC	1NO	XN5E-BV413MF①	XN5E-BV413M①	
	2NC	2NO	XN5E-BV422MF①	XN5E-BV422M①	



- Specify a color code in place of ① in the Part No.
- Only solid wires can be used on the IP20 fingersafe terminal switches.

### Illuminated Pushlock Pull/Turn Reset (Solder Terminal)

Shape	Illumination	Rated Voltage	NC Main Contact	NO Monitor Contact	Part No.		Operator Color
					IP20 Fingersafe Terminal	w/Terminal Cover	
 	LED	24V AC/DC	1NC	—	XN5E-LV401Q4MFR	XN5E-LV401Q4MR	Red only
			2NC	—	XN5E-LV402Q4MFR	XN5E-LV402Q4MR	
			3NC	—	XN5E-LV403Q4MFR	XN5E-LV403Q4MR	
			4NC	—	XN5E-LV404Q4MFR	XN5E-LV404Q4MR	
			1NC	1NO	XN5E-LV411Q4MFR	XN5E-LV411Q4MR	
			2NC	1NO	XN5E-LV412Q4MFR	XN5E-LV412Q4MR	
			3NC	1NO	XN5E-LV413Q4MFR	XN5E-LV413Q4MR	
			2NC	2NO	XN5E-LV422Q4MFR	XN5E-LV422Q4MR	

- Only solid wires can be used on the IP20 fingersafe terminal switches.

### Illuminated Push-ON Pushlock Pull/Turn Reset (Solder Terminal)

Shape	Illumination	Rated Voltage	NC Main Contact	NO Monitor Contact	Part No.		Operator Color
					IP20 Fingersafe Terminal	w/Terminal Cover	
 	LED	24V AC/DC	2NC	—	XN5E-TV402Q4MFR	XN5E-TV402Q4MR	Red only
			3NC	—	XN5E-TV403Q4MFR	XN5E-TV403Q4MR	
			2NC	1NO	XN5E-TV412Q4MFR	XN5E-TV412Q4MR	

- Push-ON is illuminated when the operator is latched, and turns off when reset.
- Only solid wires can be used on the IP20 fingersafe terminal switches.



# XN Series Emergency Stop Switches ø30



## Padlockable

### Non-illuminated Pushlock Pull/Turn Reset (Padlockable)

Shape	NC Main Contact	NO Monitor Contact	Part No.		Operator Color
			IP20 Fingersafe Terminal	w/Terminal Cover	
 	1NC	—	XN4E-BL401MFRH	XN4E-BL401MRH	Bright red only
	2NC	—	XN4E-BL402MFRH	XN4E-BL402MRH	
	3NC	—	XN4E-BL403MFRH	XN4E-BL403MRH	
	4NC	—	XN4E-BL404MFRH	XN4E-BL404MRH	
	1NC	1NO	XN4E-BL411MFRH	XN4E-BL411MRH	
	2NC	1NO	XN4E-BL412MFRH	XN4E-BL412MRH	
	3NC	1NO	XN4E-BL413MFRH	XN4E-BL413MRH	
	2NC	2NO	XN4E-BL422MFRH	XN4E-BL422MRH	



- Only solid wires can be used on the IP20 fingersafe terminal switches.
- Padlocks and hasps are not supplied with the emergency stop switches and must be ordered separately. See page 12.

### Illuminated Pushlock Pull/Turn Reset (Padlockable)

Shape	Illumination	Rated Voltage	NC Main Contact	NO Monitor Contact	Part No.		Operator Color
					IP20 Fingersafe Terminal	w/Terminal Cover	
 	LED	24V AC/DC	1NC	—	XN4E-LL401Q4MFR	XN4E-LL401Q4MR	Red only
			2NC	—	XN4E-LL402Q4MFR	XN4E-LL402Q4MR	
			3NC	—	XN4E-LL403Q4MFR	XN4E-LL403Q4MR	
			4NC	—	XN4E-LL404Q4MFR	XN4E-LL404Q4MR	
			1NC	1NO	XN4E-LL411Q4MFR	XN4E-LL411Q4MR	
			2NC	1NO	XN4E-LL412Q4MFR	XN4E-LL412Q4MR	
			3NC	1NO	XN4E-LL413Q4MFR	XN4E-LL413Q4MR	
			2NC	2NO	XN4E-LL422Q4MFR	XN4E-LL422Q4MR	

- Only solid wires can be used on the IP20 fingersafe terminal switches.
- Padlocks and hasps are not supplied with the emergency stop switches and must be ordered separately. See page 12.

### LED Push-ON Pushlock Pull/Turn Reset (Padlockable)

Shape	Illumination	Rated Voltage	NC Main Contact	NO Monitor Contact	Part No.		Operator Color
					IP20 Fingersafe Terminal	w/Terminal Cover	
 	LED	24V AC/DC	2NC	—	XN4E-TL402Q4MFR	XN4E-TL402Q4MR	Red only
			3NC	—	XN4E-TL403Q4MFR	XN4E-TL403Q4MR	
			2NC	1NO	XN4E-TL412Q4MFR	XN4E-TL412Q4MR	

- Push-ON is illuminated when the operator is latched, and turns off when reset.
- Only solid wires can be used on the IP20 fingersafe terminal switches.
- Padlocks and hasps are not supplied with the emergency stop switches and must be ordered separately. See page 12.

# ø30 XN Series Emergency Stop Switches

## Dimensions

Plastic Bezel  
Non-illuminated  
IP20 Fingersafe

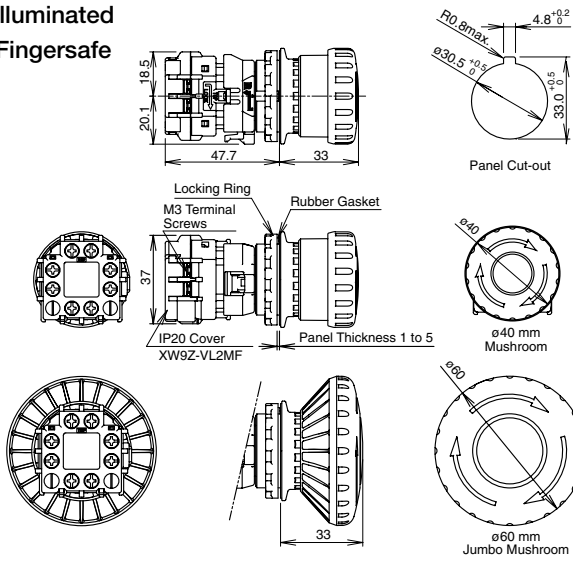

w/Terminal Cover

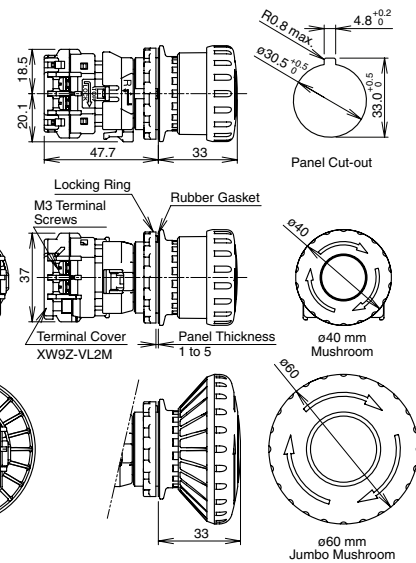

## Illuminated/Push-ON

IP20 Fingersafe

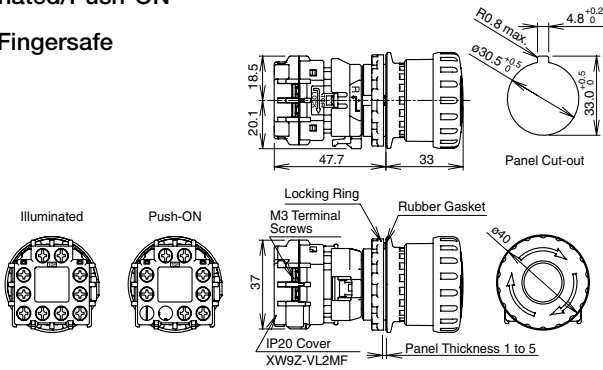

w/Terminal Cover

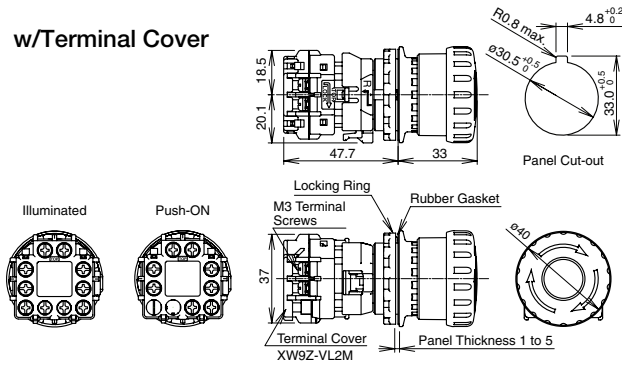

## Flush Bezel

Non-Illuminated

IP20 Fingersafe

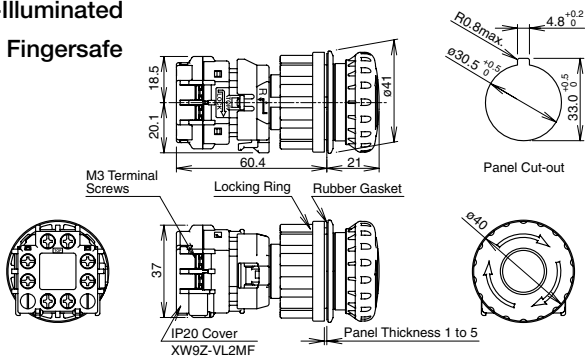

w/Terminal Cover

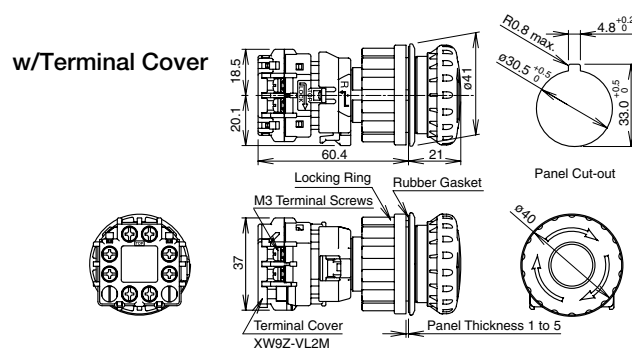

## Illuminated/Push-ON

IP20 Fingersafe

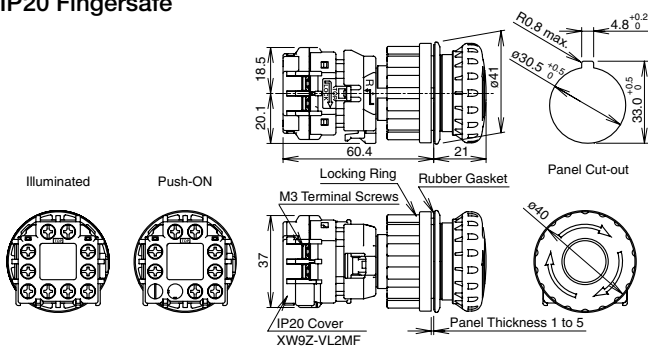

w/Terminal Cover

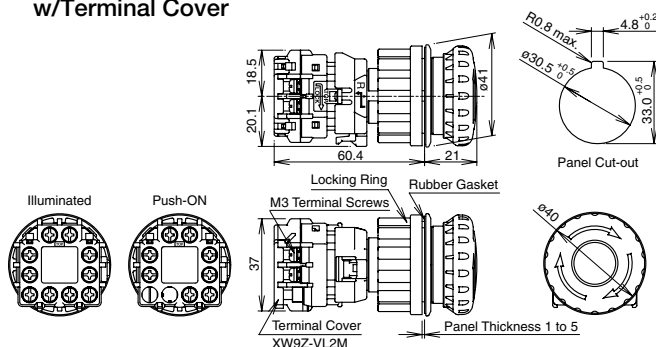

All dimensions in mm.

# XN Series Emergency Stop Switches $\phi 30$

## Dimensions

Padlockable  
Non-illuminated  
IP20 Fingersafe

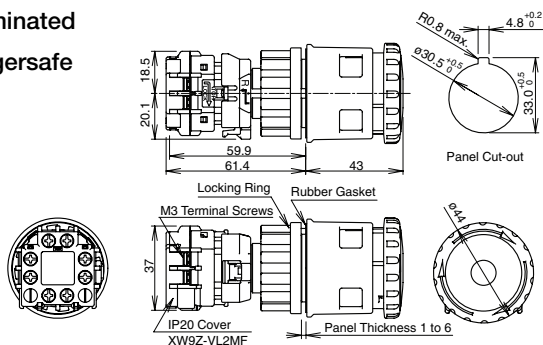

w/ Terminal Cover

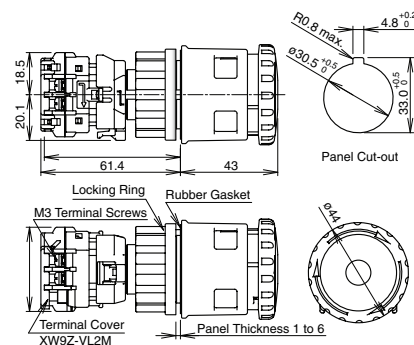

illuminated/Push-ON

IP20 Fingersafe

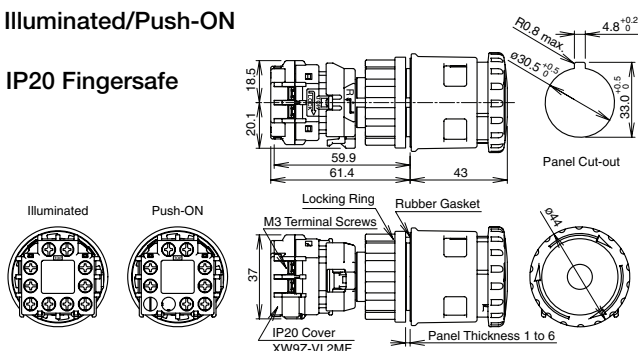

w/ Terminal Cover

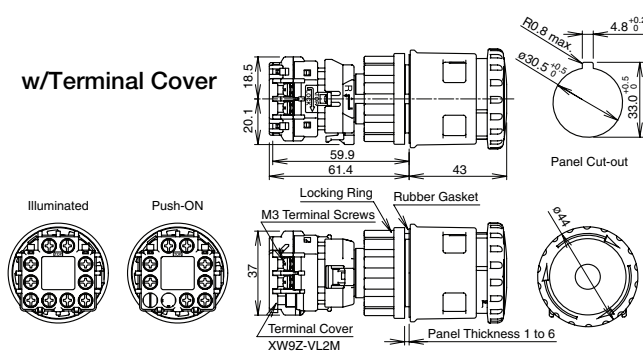

## Mounting Hole Layout

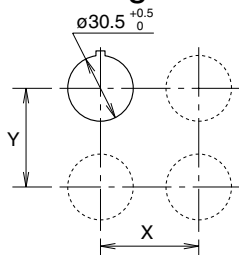

	X	Y
Plastic Bezel	70 mm minimum	
Flush Bezel	70 mm minimum	

- The values shown above are the minimum dimensions for mounting with other  $\phi 30$  mm pushbuttons. For other switches & pilot lights of different sizes and styles, determine the values according to the dimensions, operation, and wiring convenience.
- For padlockable, determine the values according to the size and number of padlocks and hasp.

## LED Unit Internal Circuit

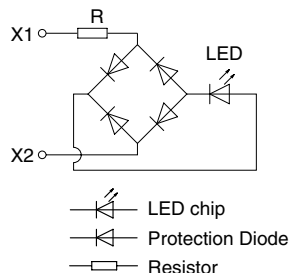

## Terminal Arrangement (Bottom View)

Non-illuminated

NC main contacts (black) only

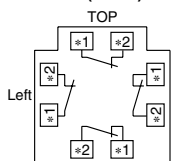

- 1NC: Terminals on right
- 2NC: Terminals on right and left
- 3NC: Terminals on right, left, and top

With 1NO monitor contact (blue)

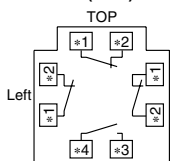

- 1NC: Terminals on top
- 2NC: Terminals on right and left

With 2NO monitor contacts (blue)

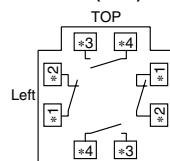

illuminated

NC main contacts (black) only

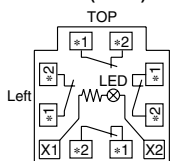

- 1NC: Terminals on right
- 2NC: Terminals on right and left
- 3NC: Terminals on right, left, and top

With 1NO monitor contact (blue)

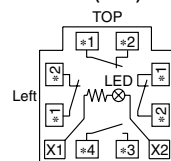

- 1NC: Terminals on top
- 2NC: Terminals on right and left

With 2NO monitor contacts (blue)

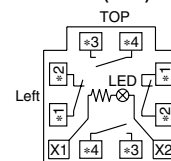

Push-ON

NC main contacts (black) only

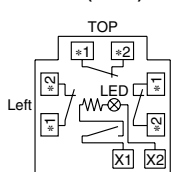

- 2NC: Terminals on right and left
- 3NC: Terminals on right, left, and top

With 1NO monitor contact (blue)

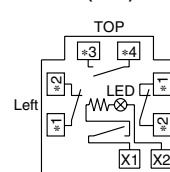

- Contact 1-2: NC main contact (black)
- Contact 3-4: NO monitor contact (blue)
- Contact Number (1-4) Starting with the contact of TOP side, in a counter-clockwise direction.

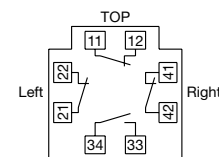

(Example: 1NO-3NC contact)

## Applicable Crimping Terminal

Ring Terminal

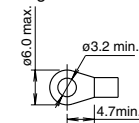

Spade Terminal

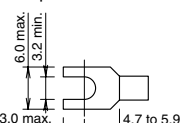

Solid Wire

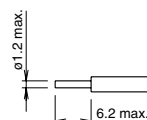

Only solid wire can be used for IP20.

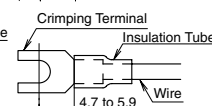
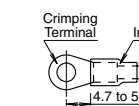





- Be sure to install an insulating tube on the crimping terminal.

All dimensions in mm.

# ø30 XN Series Emergency Stop Switches

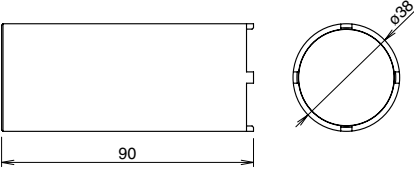
## Accessories and Replacement Parts

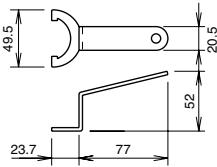
Name & Shape	Material	Part No.	Ordering No.	Package Quantity	Remarks
	PPE	XW9Z-VL2M	XW9Z-VL2MPN02	2	<ul style="list-style-type: none"> <li>Black</li> <li>Used for screw terminals.</li> <li>Attached to IP20 protection cover units.</li> </ul>
	Polyamide	XW9Z-VL2MF	XW9Z-VL2MF-PN02	2	<ul style="list-style-type: none"> <li>Black</li> <li>Used to change terminal cover to IP20 fingersafe terminal.</li> <li>Only solid wires can be used. Once installed, IP20 terminal cover cannot be removed.</li> </ul>
	Brass	XN9Z-T1	XN9Z-T1	1	<ul style="list-style-type: none"> <li>Used to tighten the locking ring when installing the XN emergency stop switch onto a panel.</li> </ul> 
	Steel Trivalent chromate plating	TWST-T1	TWST-T1	1	<ul style="list-style-type: none"> <li>Used to tighten the locking ring when installing the XN emergency stop switch onto a panel.</li> </ul> 

- The XN series emergency stop switches are supplied with either terminal cover or IP20 fingersafe terminal cover.
- Padlocks and hasps are not supplied and must be ordered separately.

## Nameplates (for ø30 Emergency Stop Switches)

Description & Shape	Legend	Part No.	Package Quantity	Dimensions (mm)
	(blank)	HNAV-0	1	Polyamide Mounting panel thickness XN4E-□L4: 1.0 to 4.5 mm XN□E-□V4: 1.0 to 3.5 mm 
	EMERGENCY STOP	HNAV-27		

Plate color: Yellow (Munsell 2.5Y 8/10 or equivalent),  
Legend: Black

## Padlock and Hasp

Padlocks and hasps of the following specifications can be used with padlockable emergency stop switches.

### Padlock Size

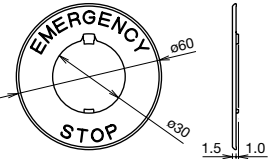
A	B	C	D
7 mm maximum	19 mm minimum	39 mm minimum	15 mm minimum (Note)

Note: When the padlock is installed from the side of the bezel, dimension D requires a minimum of 6 mm. When the padlock is installed from the front of the button, dimension D requires a minimum of 15 mm.

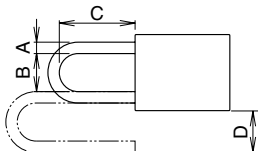

Manufacturer	Part No.
PANDUIT CORP.	PSL-HD3 PSL-1A
Master Lock	420 421

Use only padlocks or hasps that satisfy the specifications shown on the left. The maximum total weight for padlocks and hasps is 1500g.

Make sure that the total weight does not exceed 1500g, otherwise the XN emergency stop switch may be damaged.

Make sure that locking and unlocking of the padlock and hasp do not interfere with other devices.

Padlocks and hasps are available from the following manufacturers.

Manufacturer	URL
PANDUIT CORP.	<a href="http://www.panduit.com/">http://www.panduit.com/</a>
Master Lock® Company LLC	<a href="http://www.masterlock.com/">http://www.masterlock.com/</a>

## Operating Instructions

### Removing the Contact Block

First unlock the operator button. Grab the yellow bayonet ring ① and pull back the bayonet ring until the latch pin clicks ②, then turn the contact block counterclockwise and pull out ③.

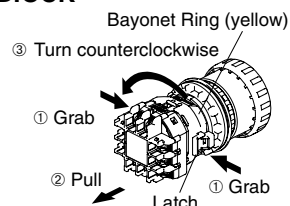

#### Notes for removing the contact block

1. Do not attempt to remove the contact block while the operator is latched, otherwise the switch may be damaged.
2. When the contact block is removed, the monitor contact (NO contact) is closed.
3. While removing the contact block, do not use excessive force, otherwise the switch may be damaged.
4. An LED lamp is built into the contact block for illuminated pushbuttons. When removing the contact block, pull the contact block straight to prevent damage to the LED lamp. If excessive force is used, the LED lamp may be damaged and fail to light.

### Panel Mounting

Remove the locking ring from the operator and check that the rubber gasket is in place. Insert the operator from panel front into the panel hole. Face the side without thread on the operator with TOP marking upward, and tighten the locking ring using ring wrench XN9Z-T1 or TWST-T1 to a torque of 2.5 N·m maximum.

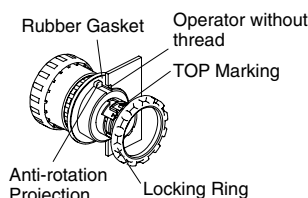

#### When using a nameplate

When using a nameplate HNAV-□, break the projection from the nameplate using pliers.



### Installing the Contact Block

First unlock the operator button.

Align the small ▼ marking on the edge of the operator with the small ▲ marking on the yellow bayonet ring. Hold the contact block, not the bayonet ring. Press the contact block onto the operator and turn the contact block clockwise until the bayonet ring clicks.

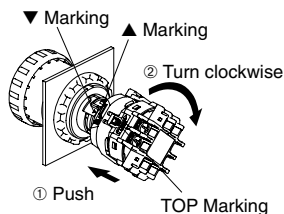

#### Notes for installing the contact block

1. Do not attempt to install the contact block when the operator is latched, otherwise the switch may be damaged.
2. Make sure that the bayonet ring is in the locked position.

### Installing & Removing Terminal Covers

To remove the terminal cover, pull out the two latches on the top side of the terminal cover. Do not exert excessive force to the latches, otherwise the latches may break.

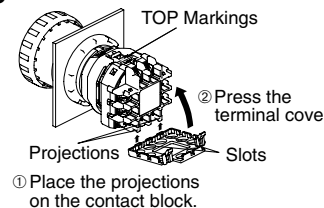

#### IP20 Fingersafe Terminal Cover XW9Z-VL2MF

To install the IP20 fingersafe terminal cover, align the TOP marking on the cover with the TOP marking on the contact block, and press the cover toward the contact block.

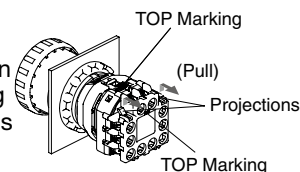

#### Notes:

1. Once installed, the XW9Z-VL2MF cannot be removed.
2. With the XW9Z-VL2MF installed, crimping terminals cannot be used. Use solid wires.
3. The XW9Z-VL2MF cannot be installed after wiring.
4. Make sure that the XW9Z-VL2MF is securely installed. IP20 cannot be achieved when installed loosely, and electric shocks may occur.

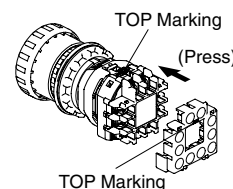

### Notes for Operation

When using the XN emergency stop switches in safety-related part of a control system, observe safety standards and regulations of the relevant country or region. Also be sure to perform a risk assessment before operation.

#### Wiring

Tighten the M3 terminal screws to a torque of 0.6 to 1.0 N·m.

#### Contact Bounce

When the button is reset by pulling or turning, the NC main contacts will bounce. When pressing the button, the NO monitor contacts will bounce. When designing a control circuit, take the contact bounce time into consideration (reference value: 20 ms).

#### LED Illuminated Switches

An LED lamp is built into the contact block and cannot be replaced.

#### Handling

Do not expose the switch to excessive shocks and vibrations, for example by operating the switch with tools. Otherwise the switch may be deformed or damaged, causing malfunction or operation failure.

# ø30 HN Series Emergency Stop Switches

## Emergency Stop Switches (Unibody) Specifications

### Standards

Applicable Standards	Mark	File No. or Organization
UL508 CSA C22.2 No. 14		UL Listing File No. E55996
EN60947-5-5		TÜV SÜD
		EU Low Voltage Directive
GB14048.5		CCC No. 2013010305610376

### Specifications

Operating Temperature	-25 to +60°C (no freezing) Illuminated units: -25 to +55°C
Storage Temperature	-40 to +80°C
Operating Humidity	45 to 85% RH (no condensation)
Operating Force	50N
Minimum Force Required for Direct Opening Action	5.5 mm
Maximum Operator Stroke	10 mm
Contact Resistance	50 mΩ maximum (initial value)
Insulation Resistance	100 MΩ minimum (500V DC megger)
Dielectric Strength	Between live and dead metal parts Contacts: 2,500V AC, 1 minute Illuminated parts: 1,000V AC, 1 minute
Vibration Resistance	Damage limits: 30 Hz, amplitude 1.5 mm Operating extremes: 5 to 55 Hz, amplitude 0.5 mm
Shock Resistance	Damage limits: 1,000 m/s <sup>2</sup> Operating extremes: 100 m/s <sup>2</sup>
Operating Frequency	900 operations/h
Life	Mechanical: 250,000 operations minimum Electrical: 100,000 operations minimum
Degree of Protection	IP65
Terminal Style	M3.5 screw
Weight (approx.)	58g (HN1E-BV402R) 65g (HN1E-LV402Q4R)

### Contact Ratings







Rated Insulation Voltage (Ui)		250V			
Rated Thermal Current (Ith)		10A			
Rated Operational Voltage (Ue)		24V	110V	220V	
Rated Operational Current	AC 50/60 Hz	Resistive Load (AC-12)	6A	3A	3A
		Inductive Load (AC-15)	6A	3A	3A
	DC	Resistive Load (DC-12)	6A	2A	1A
		Inductive Load (DC-13)	1.5A	0.3A	0.15A

Note: The operational current represents the classification by making and breaking currents (IEC 60947-5-1). Minimum applicable load (reference value): 3V AC/DC, 5 mA (Applicable range may vary with operating conditions and load types.)

### LED Lamp Ratings







Rated Operating Voltage of Unit	LED Lamp		
	Part No.	Rated Voltage	Rated Current
24V AC/DC	LSTD-2R	24V AC/DC ±10%	10 mA

## Pushlock Turn Reset Switches (Unibody)

Shape	Contact	Part No.	Button Color
     	1NO-1NC	HN1E-BV411R	Red only
	2NC	HN1E-BV402R	

- When pressed, the button is held depressed. The button is released by turning clockwise.
- Terminal cover HW-VL7 is supplied with the switch.

## Illuminated Pushlock Turn Reset Switches (Unibody)

Shape	Lamp	Contact	Part No.	Lens Color
     	Without Lamp	1NO-1NC	HN1E-LV411Q0R	Red only
		2NC	HN1E-LV402Q0R	

- When pressed, the button is held depressed. The button is released by turning clockwise.
- Terminal cover HW-VL7 is supplied with the switch.

### Maintenance Parts

Name	Part No.	Ordering No.	Package Quantity
Terminal Cover for HW1E	HW-VL7	HW-VL7PN10	10

# HN Series Emergency Stop Switches $\phi 30$

## Dimensions

### HN1E-BV4

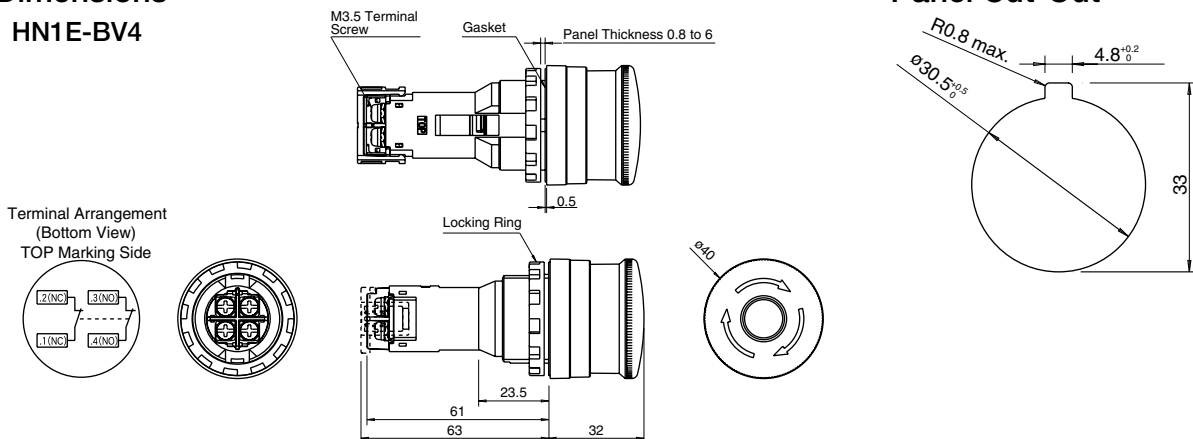

### HN1E-LV4

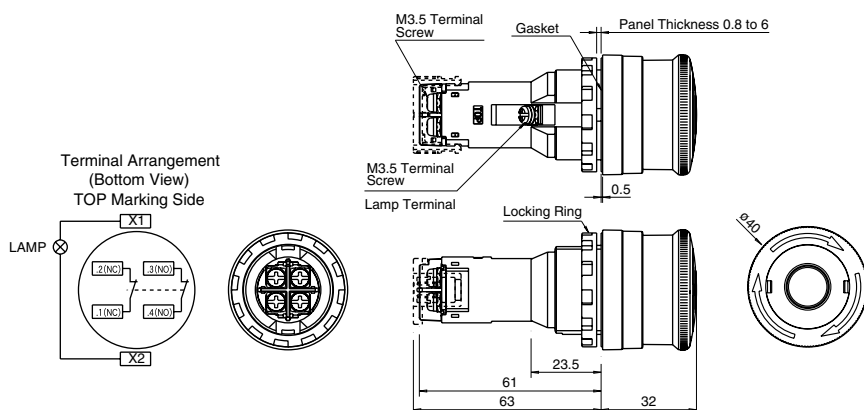

All dimensions in mm.

## Accessory

Shape	Material	Part No.	Package Quantity	Remarks
	Metal (zinc-plated)	TWST-T1	1	<ul style="list-style-type: none"> <li>Used for tightening the locking nut.</li> <li>Tighten the locking nut to a torque of 2.0 to 2.5 N·m.</li> </ul>
	Brass	XN9Z-T1	1	<ul style="list-style-type: none"> <li>Used to tighten the locking ring when installing the XN emergency stop switch onto a panel.</li> </ul>

## Nameplates (for $\phi 30$ Emergency Stop Switches)

Shape	Part No.	Legend	Package Quantity	Remarks
	HNAV-0	(blank)	1	Background: Yellow Legend: Black Applicable panel thickness: 0.8 to 4.5 mm Material: Polyamide Legend "EMERGENCY STOP" is indicated outside a $\phi 44$ mm circle.
	HNAV-27	EMERGENCY STOP		

# ø30 Series Switches & Pilot Lights

**Heavy duty switches & pilot lights offer both variety and reliability  
Endures harsh environments**

- Degree of protection: IP65
- UL, CSA approved, and EN compliant.

Applicable Standards	Mark	File No. or Organization
UL 508		UL Listing File No. E68961
CSA C22.2 No.14		CSA File No. LR21451
EN60947-5-1		EU Low Voltage Directive
GB14048.5		CCC No. 200501030514658



## Specifications and Ratings

### Contact Ratings

Pushbuttons	Contact Block	BS/BST (ø30 series)
Illuminated Pushbuttons	Rated Insulation Voltage	600V
Selector Switches	Rated Continuous Current	10A
Illuminated Selector Switches	Contact Ratings by Utilization Category	AC-15 (A600)
Selector Pushbuttons	IEC 60947-5-1	DC-13 (P600)

### Characteristics

#### Contact Ratings by Utilization Category

Operational Voltage			24V	48V	50V	110V	220V	440V
Operational Current	AC 50/60 Hz	AC-12 Control of resistive loads and solid state loads	10A	—	10A	10A	6A	2A
		AC-15 Control of electromagnetic loads (> 72 VA)	10A	—	7A	5A	3A	1A
	DC	DC-12 Control of resistive loads and solid state loads	10A	5A	—	2.2A	1.1A	—
		DC-13 Control of electromagnets	5A	2A	—	1.1A	0.6A	—

Note: The operational current represents the classification by making and breaking currents (IEC 60947-5-1).  
Minimum applicable load: 3V AC/DC, 5 mA (applicable range may vary with operating conditions and load types)  
For mono-levers and cam switches, see pages 47 and 50.

### BS (BST) Contact Block

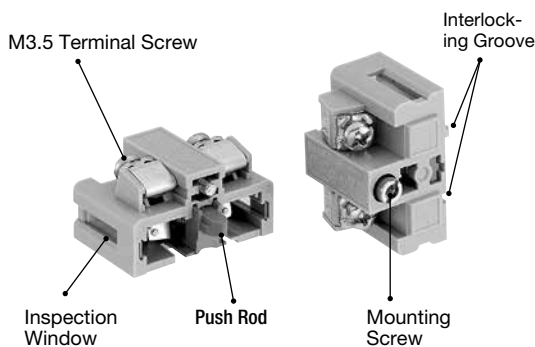

#### Contact Blocks

Contact		Single-pole Contact Block			
Part No.	BS	BS010E	BS001E	BS010SE	BS001SE
	BST	BST010	BST001	BST010S	BST001S
Push Rod		Green	Red	Black	White

BST contact blocks are used for the following switches and are not interchangeable with BS contact blocks.  
(The BS housing is dark gray and the BST housing is light gray.)

- Pushlock turn reset and push turn lock switches
- LED illuminated pushbuttons
- LED illuminated selector switches
- All models of diecast zinc housing switches & pilot lights

- Durable nylon 66 housing has a high resistance against alkalis.
- Silver contacts. Gold contact (gold-plated silver) also available.
- Up to four blocks in two layers can be mounted onto each operator.



# ø30 Series Switches & Pilot Lights ø30

## LED Illuminated Unit Specifications

Unit	Color Code ②	Input	Operating Voltage	LED Lamp			
				Lamp Base	Part No.	Voltage	
Pilot Light Illuminated Pushbutton Illuminated Selector Switch	A: amber G: green PW: pure white R: red S: blue W: white Y: yellow	Full Voltage	6V AC/DC	BA9S/13	LSTD-6②	6V AC/DC ±10%	
			12V AC/DC			LSTD-1②	12V AC/DC ±10%
			24V AC/DC			LSTD-2②	24V AC/DC ±10%
		Transformer	100/110V AC 120V AC 200/220V AC 240V AC 380V AC 400/440V AC (50/60 Hz)	BA9S/13	LSTD-6②	6V AC/DC ±10%	
DC-DC Converter	110V DC	BA9S/13	LSTD-6②	6V AC/DC ±10%			

Note: Use a pure white (PW) LED for yellow (Y) illumination.

## LED Lamp Ratings (LSTD)

Part No.	LSTD-6②	LSTD-1②	LSTD-2②
Lamp Base	BA9S/13		
Rated Voltage	6V AC/DC	12V AC/DC	24V AC/DC
Voltage Range	6V AC/DC ±10%	12V AC/DC ±10%	24V AC/DC ±10%
Current Draw	AC	8 mA	11 mA
	DC	A, R, W: 7 mA G, PW, S: 5.5 mA	10 mA
Color Code ②	A (amber), G (green), PW (pure white), R (red), S (blue), W (white)		
Lamp Base Color	Same as illumination color		
Voltage Marking	Die stamped on the base		
Life (reference value)	Approx. 50,000 hours (The luminance is reduced to 50% the initial intensity when used on complete DC.)		
Internal Circuit	<p>The diagram shows an internal circuit with two input terminals, X1 and X2. X1 is connected to a resistor, which is in series with a bridge rectifier. The bridge rectifier consists of four diodes. One of the diodes in the bridge is an LED chip. A protection diode is connected in parallel with the LED chip. A zener diode is connected in parallel with the protection diode. The other terminal of the zener diode is connected to the other side of the bridge rectifier.</p> <ul style="list-style-type: none"> <li> LED Chip</li> <li> Protection Diode</li> <li> Zener Diode</li> <li> Resistor</li> </ul>		

Note: Use a pure white (PW) LED for yellow (Y) illumination.

# ø30 ø30 Series Switches & Pilot Lights

## Specifications

Operating Temperature	-25 to +50°C (no freezing)	
Storage Temperature	-40 to +80°C (no freezing)	
Operating Humidity	45 to 85% RH (no condensation)	
Contact Resistance	50 mΩ maximum (initial value)	
Insulation Resistance	100 MΩ minimum (500V DC megger)	
Dielectric Strength	Between live and dead metal parts: 2,500V AC, 1 minute (Full voltage and pilot lights: 2,000V AC, 1 minute)	
Vibration Resistance	Operating extremes: 5 to 55 Hz, amplitude 0.5 mm	
Shock Resistance	Damage limits: 1,000 m/s <sup>2</sup> Operating extremes: 100 m/s <sup>2</sup>	
Mechanical Life (minimum operations)	Pushbuttons Momentary: 5,000,000 Maintained: 500,000 Illuminated pushbuttons Momentary: 2,500,000 Maintained: 500,000 Selector switches: 500,000 Key selector switches: 500,000 Illuminated selector switches: 500,000 Selector pushbuttons: 250,000 Mono-lever switches: 500,000 (Interlocking): 250,000 Pushlock turn reset: 500,000 Mushroom push-pull switch Two contact blocks: 500,000 Four contact blocks: 200,000	
Electrical Life (minimum operations)	Pushbuttons: 500,000 *1 Illuminated pushbuttons: 500,000 *1 Selector switches: 500,000 *2 Key selector switches: 500,000 *2 Illuminated selector switches: 500,000 *2 Selector pushbuttons: 250,000 *2 Mono-lever switches: 500,000 *3 (Interlocking): 250,000 *3 *1 Switching frequency 1,800 operations/h, duty ratio 40% *4 *2 Switching frequency 1,200 operations/h, duty ratio 40% *3 Switching frequency 900 operations/h, duty ratio 40% *4 Switching frequency 900 operations/h for square twin or twin maintained	

## Degree of Protection

Part No.	Unit	IEC 60529
A****	Pushbuttons, pilot lights, illuminated pushbuttons, selector switches, selector pushbuttons, mono-lever switches, and cam switches (ACSNO/ACSSO)	IP65
	Illuminated selector switches, key pushbuttons, key reset pushbuttons, key cam switches, and key selector switches	IP54
U****	Square pushbuttons, square pilot lights, and cam switches (UC)	IP40

Note: (3S) of NEMA ICS 6-110 applies to the pilot lights with round lens.

## Mounting Hole Layout

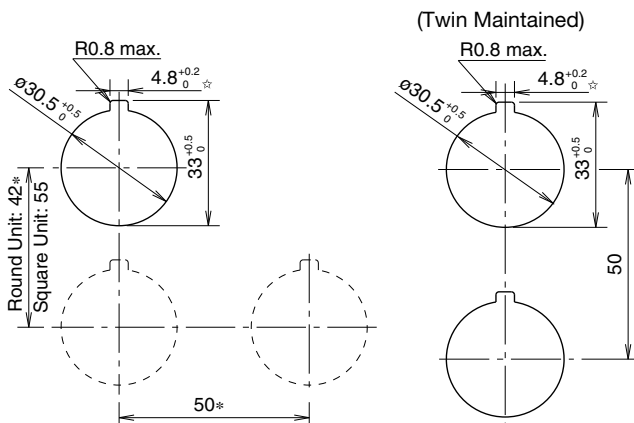

\*The minimum mounting centers are applicable to switches with one layer of contact blocks (two contact blocks). When two layers of contact blocks (four contact blocks) are mounted, determine the minimum mounting centers in consideration of convenience for wiring.

- Mushroom with shroud: 50 mm minimum
- Jumbo mushroom: 67 mm minimum
- Jumbo mushroom with shroud: 76 mm minimum
- Square twin: 55 mm minimum
- Selector switch with lever: 50 mm minimum

☆ The 4.8 mm recess is for preventing rotation and is not necessary when the nameplate or anti-rotation ring is not used.

Note: For mounting hole layout of pushbuttons, mono-lever switches, and cam switches, see each section.

# ø30 Series Switches & Pilot Lights (Ordering Information) ø30

## Ordering Information

### Standard Units

- Specify an operator or Lens/LED Color Code in the Part No.
- Black, green, and red buttons are included with flush pushbuttons.
- Terminal covers, nameplates, and accessories are ordered separately.

### Terminal Cover

- When a terminal cover is required, order an applicable terminal cover referring to page 59.

The Part No. development charts shown below can be used to specify switches and pilot lights other than those listed on the following pages. Gold-plated silver contacts are also available.

### ø30 Series Pushbuttons

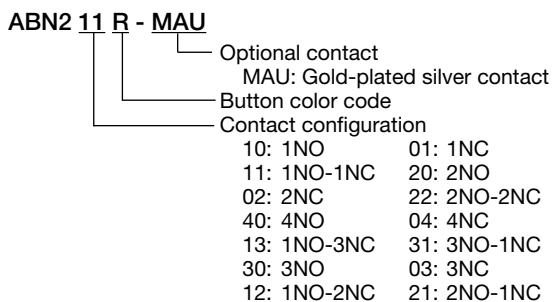

Note:

- Mushroom pull ATN23 can have a maximum of two contact blocks.
- Mushroom push-pull return ATN22 cannot have only NO or only NC contacts.
- No other contact configurations are available for square twin UWQN1 than those specified in this catalog.

### ø30 Series Illuminated Pushbuttons

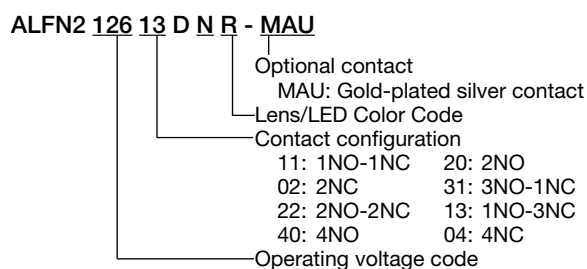

Note:

- Illuminated pushbuttons cannot have an odd number of contact blocks, such as 1NO, 1NC, 3NO, 2NO-1NC, 1NO-2NC, and 3NC

### ø30 Series Pilot Lights

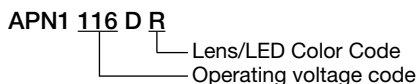

Note:

- LED lamps cannot be used on 480V AC transformers.

# ø30 ø30 Series Switches & Pilot Lights (Ordering Information)

## ø30 Series Selector Switch

ASN 2 L 11 - MAU

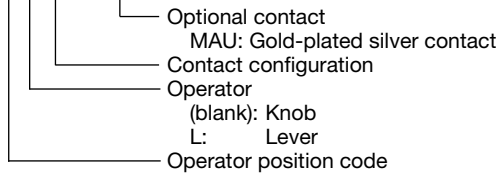

## ø30 Series Illuminated Selector Switch

ASLN 2 16 22 D N R - MAU

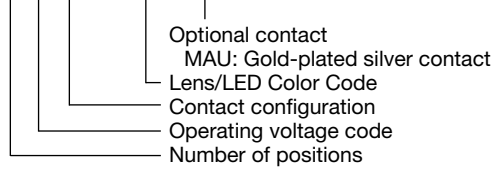

## ø30 Series Key Selector Switch

ASN 2 K 11 D - MAU

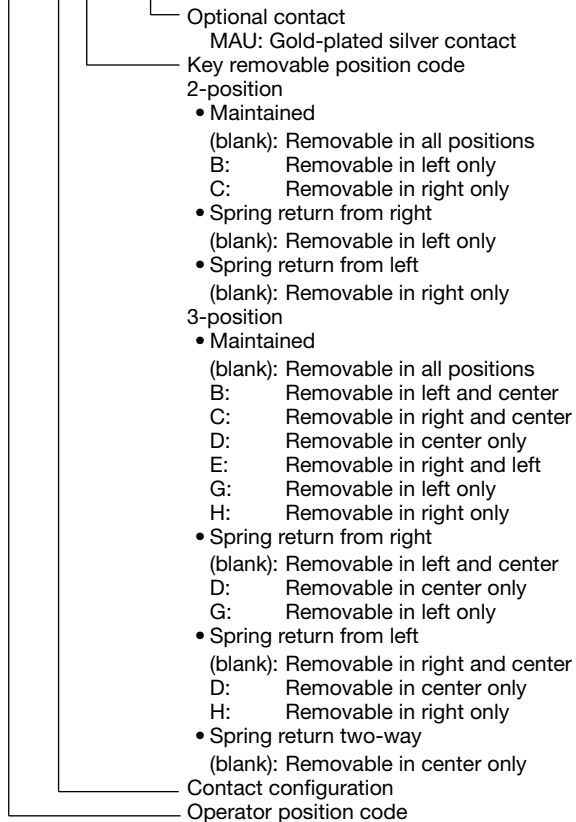











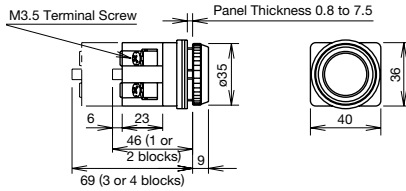

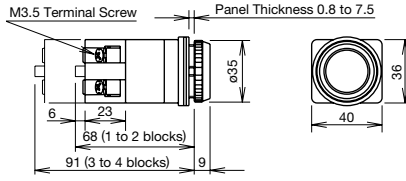

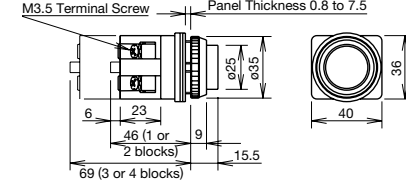
Note:

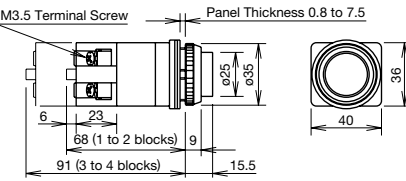
- The key cannot be removed in the return position.

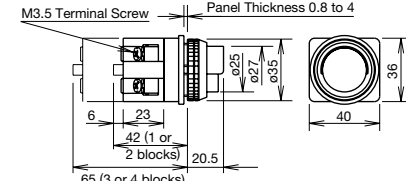
ø30 series Pushbuttons ø30

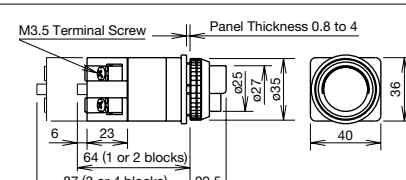
Flush / Extended / Extended w/Half Shroud / Extended w/Full Shroud Pushbuttons

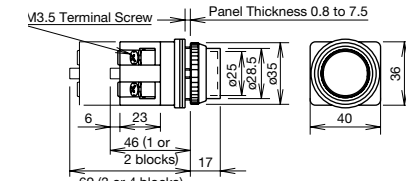
Package Quantity: 1

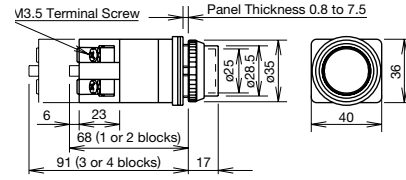











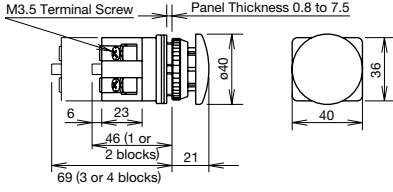

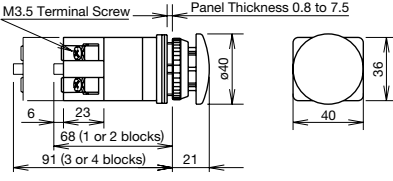

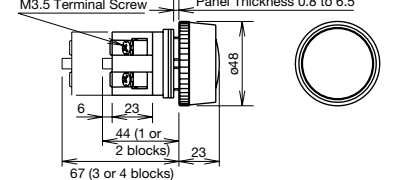
Shape	Operation	Contact	Part No.	① Button Color Code	Dimensions (mm)
Flush ABN1  (nameplate sold separately)	Momentary	1NO	ABN110①	Black (B), green (G), and red (R) buttons are supplied with each unit.	
		1NC	ABN101①		
		1NO-1NC	ABN111①		
		2NO	ABN120①		
		2NC	ABN102①		
Flush AON1  (nameplate sold separately)	Maintained	1NO	AON110①	Specify S, W, or Y when a blue, white, or yellow button is required.	
		1NC	AON101①		
		1NO-1NC	AON111①		
		2NO	AON120①		
		2NC	AON102①		
Extended ABN2  (nameplate sold separately)	Momentary	1NO	ABN210①		
		1NC	ABN201①		
		1NO-1NC	ABN211①		
		2NO	ABN220①		
		2NC	ABN202①		
Extended AON2  (nameplate sold separately)	Maintained	1NO	AON210①		
		1NC	AON201①		
		1NO-1NC	AON211①		
		2NO	AON220①		
		2NC	AON202①		
Extended with Half Shroud ABN2G  (nameplate sold separately)	Momentary	1NO	ABN2G10①	Specify a button color code in place of ① in the Part No.	
		1NC	ABN2G01①		
		1NO-1NC	ABN2G11①		
		2NO	ABN2G20①		
		2NC	ABN2G02①		
Extended with Half Shroud AON2G  (nameplate sold separately)	Maintained	1NO	AON2G10①	B: black G: green R: red S: blue W: white Y: yellow	
		1NC	AON2G01①		
		1NO-1NC	AON2G11①		
		2NO	AON2G20①		
		2NC	AON2G02①		
Extended with Full Shroud ABN2F  (nameplate sold separately)	Momentary	1NO	ABN2F10①		
		1NC	ABN2F01①		
		1NO-1NC	ABN2F11①		
		2NO	ABN2F20①		
		2NC	ABN2F02①		
Extended with Full Shroud AON2F  (nameplate sold separately)	Maintained	1NO	AON2F10①		
		1NC	AON2F01①		
		1NO-1NC	AON2F11①		
		2NO	AON2F20①		
		2NC	AON2F02①		

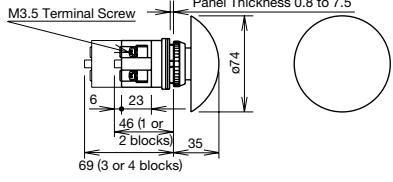
- Round bezel and shroud (metal): Chrome-plated
- Other contact configurations and gold-plated silver contacts are also available. See page 19.

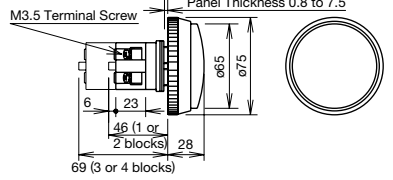
# ø30 ø30 Series Pushbuttons

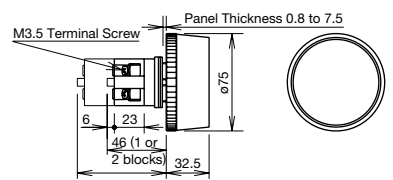
## Mushroom / Jumbo Mushroom / Square Flush / Square Extended Pushbuttons

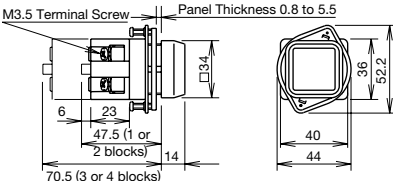
Package Quantity: 1

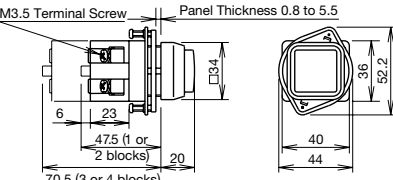





Shape	Operation	Contact	Part No.	① Button Color Code	Dimensions (mm)
<b>Mushroom ABN3</b>  	Momentary	1NO	ABN310①	B: black G: green R: red S: blue W: white Y: yellow	
		1NC	ABN301①		
		1NO-1NC	ABN311①		
		2NO	ABN320①		
		2NC	ABN302①		
		2NO-2NC	ABN322①		
<b>Mushroom AON3</b>  	Maintained	1NO	AON310①		
		1NC	AON301①		
		1NO-1NC	AON311①		
		2NO	AON320①		
		2NC	AON302①		
		2NO-2NC	AON322①		
<b>Mushroom with Full Shroud ABN3G</b>  	Momentary	1NO	ABN3G10①		
		1NC	ABN3G01①		
		1NO-1NC	ABN3G11①		
		2NO	ABN3G20①		
		2NC	ABN3G02①		
		2NO-2NC	ABN3G22①		
<b>Palm Mushroom ABN4</b>  	Momentary	1NO	ABN410①		
		1NC	ABN401①		
		1NO-1NC	ABN411①		
		2NO	ABN420①		
		2NC	ABN402①		
		2NO-2NC	ABN422①		
<b>Jumbo Mushroom with Shallow Shroud ABN4G</b>  	Momentary	1NO	ABN4G10①		
		1NC	ABN4G01①		
		1NO-1NC	ABN4G11①		
		2NO	ABN4G20①		
		2NC	ABN4G02①		
		2NO-2NC	ABN4G22①		
<b>Jumbo Mushroom with Deep Shroud ABN4F</b>  	Momentary	1NO	ABN4F10①		
		1NC	ABN4F01①		
		1NO-1NC	ABN4F11①		
		2NO	ABN4F20①		
		2NC	ABN4F02①		
		2NO-2NC	ABN4F22①		
<b>Square Flush UBQN1</b>  	Momentary	1NO	UBQN110①	B: black G: green R: red Y: yellow	
		1NC	UBQN101①		
		1NO-1NC	UBQN111①		
		2NO	UBQN120①		
		2NC	UBQN102①		
		2NO-2NC	UBQN122①		
<b>Square Extended UBQN2</b>  	Momentary	1NO	UBQN210①		
		1NC	UBQN201①		
		1NO-1NC	UBQN211①		
		2NO	UBQN220①		
		2NC	UBQN202①		
		2NO-2NC	UBQN222①		

- Specify a button color code in place of ① in the Part No.
- Round/square bezel and shroud (metal): Chrome-plated
- Other contact configurations and gold-plated silver contacts are also available. See page 19.

ø30 Series Pushbuttons ø30

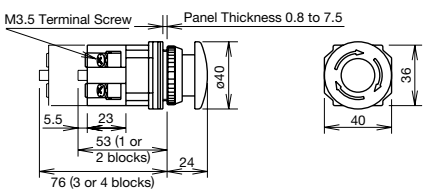
**Pushlock Turn Reset / Pushlock Key Reset / Push Turn Lock / Key ON/OFF Lock / Toggle Lever Pushbuttons**

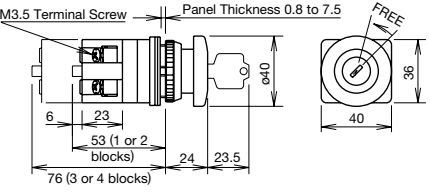

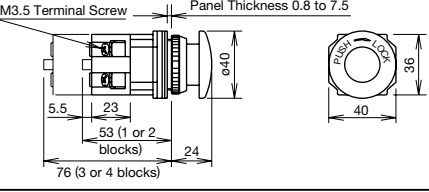
Package Quantity: 1

Shape	Contact	Part No.	① Button Color Code	Dimensions (mm)
Mushroom Pushlock Turn Reset AVN3  	1NO	AVN310N①	R: red Y: yellow	
	1NC	AVN301N①		
	1NO-1NC	AVN311N①		
	2NO	AVN320N①		
	2NC	AVN302N①		
	2NO-2NC	AVN322N①		
Mushroom Pushlock Key Reset ABN3K  	1NO	ABN3K10①	B: black G: green R: red Y: yellow	
	1NC	ABN3K01①		
	1NO-1NC	ABN3K11①		
	2NO	ABN3K20①		
	2NC	ABN3K02①		
	2NO-2NC	ABN3K22①		
Pushlock Push Turn Lock AJN3  	1NO	AJN310N①	B: black G: green R: red Y: yellow	
	1NC	AJN301N①		
	1NO-1NC	AJN311N①		
	2NO	AJN320N①		
	2NC	AJN302N①		
	2NO-2NC	AJN322N①		

- Specify a button color code in place of ① in the Part No.
  - Round bezel (metal): Chrome-plated
  - Cylinder (metal): Chrome-plated
  - Other contact configurations and gold-plated silver contacts are also available. See page 19.
  - **Pushlock Turn Reset:** Button is maintained when pressed and is reset when turned clockwise. Red buttons only.
- Note: ø30 pushlock turn reset switches cannot be used as emergency stop switches. When emergency stop switches are required, use XN or HN series emergency stop switches (ISO 13850 and IEC 60947-5-5 compliant).
- **Pushlock Key Reset:** Button is maintained when pressed and is reset with a key. Key is removable from both depressed and reset positions. Two keys are supplied.
- Note: ø30 pushlock key reset switches cannot be used as emergency stop switches. When emergency stop switches are required, use HW series emergency stop switches with a HW9Z-A30 ring adapter (ISO 13850 and IEC 60947-5-5 compliant).
- **Push Turn Lock:** Button is locked when turned clockwise in the depressed position and is reset when turned counterclockwise.

## Pull / Push-Pull / Pin Lock Pushbuttons

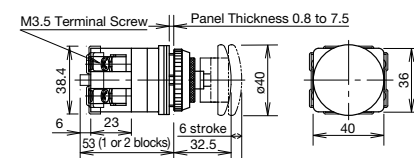
Package Quantity: 1

Shape	Contact	Part No.	① Button Color Code	Dimensions (mm)
Mushroom Pull ATN23  (nameplate sold separately)	1NO	ATN2310①	B: black G: green R: red Y: yellow	
	1NO-1NC	ATN2311①		
	2NO	ATN2320①		
	2NC	ATN2302①		
Mushroom Push-Pull ATN21  (nameplate sold separately)	1NO-1NC	ATN2111①		
	2NO	ATN2120①		
	2NC	ATN2102①		
	2NO-2NC	ATN2122①		
Mushroom Push-Pull Return ATN22  (nameplate sold separately)	1NO-1NC	ATN2211①		
	2NO-2NC	ATN2222①		

- Specify a button color code in place of ① in the Part No.
  - Round bezel and shroud (metal): Chrome-plated
  - Square bezel (metal): Chrome-plated
  - Other contact configurations and gold-plated silver contacts are also available. See page 19.
  - **Pull:** Pulling the button operates the contacts, and releasing the button return the contacts. Suitable to prevent unintended operation when an object touches the pushbutton. Up to 2 contact blocks (1 layer) can be mounted on pull switches.
  - **Push-Pull:** 2-position pushbutton. Pushing or pulling operates the contacts. Button is maintained in both depressed and reset positions.
  - **Push-Pull Return:** 3-position pushbutton. Pushing or pulling the button operates the contacts. Button is spring-returned to the center position.
- Note: ø30 push pull switches cannot be used as emergency stop switches. When emergency stop switches are required, use XN series emergency stop switches (ISO 13850 and IEC 60947-5-5 compliant).

### Contact Operation

Contact	ATN23	
	Normal	Pull
1NO		
1NC		
1NO-1NC		
2NO		
2NC		









Contact	ATN21	
	Push	Pull
1NO-1NC		
2NO		
2NC		
2NO-2NC		

Contact	ATN22		
	Push	Normal	Pull
1NO-1NC			
2NO-2NC			

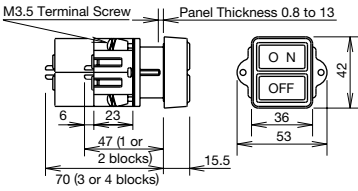

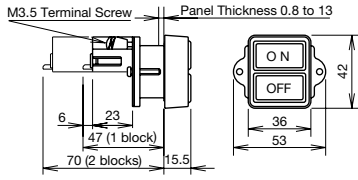
**Square Twin / Twin Maintained Pushbuttons**

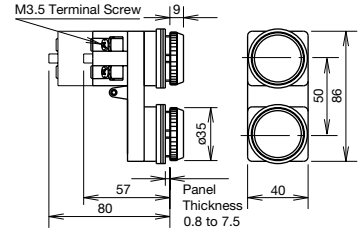
Package Quantity: 1

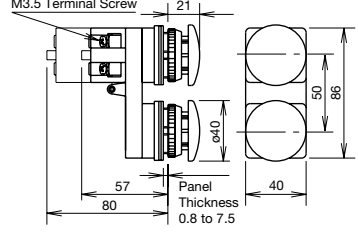

Shape	Contact		Part No.	Button Color	Dimensions (mm)
Square Twin (Momentary) UWQN1  	ON	OFF		ON: Black OFF: Red	
	1NO	1NO	UWQN11010		
	1NO	1NC	UWQN11001		
	2NO	2NC	UWQN12002		
Square Twin (Maintained) UWQN2  	ON	OFF		ON: Black OFF: Red	
	1NO	-	UWQN21000		
	1NC	-	UWQN20100		
	1NO-1NC	-	UWQN21100		
	2NO	-	UWQN22000		
	2NC	-	UWQN20200		
Flush Twin Maintained ABBN11  	Top	Bottom		Black (B), green (G), and red (R) buttons are supplied with each unit.	
	1NO	-	ABBN1110		
	1NC	-	ABBN1101		
	1NO-1NC	-	ABBN1111		
	2NO	-	ABBN1120		
		2NC	-		
Mushroom Twin Maintained (Without buttons) ABBN33  	Top	Bottom			
	1NO	-	ABBN3310		
	1NC	-	ABBN3301		
	1NO-1NC	-	ABBN3311		
	2NO	-	ABBN3320		
		2NC	-		
	2NO-2NC	-	ABBN3322		

- Round bezel (metal): Chrome-plated
  - Other contact configurations and gold-plated silver contacts are also available. See page 19.
  - **Square Twin (Momentary):** Two independent momentary switches are contained in one unit, each operated by ON or OFF button. With the ø30 adapter removed from the sleeve, the unit can mount in a ø25.5mm mounting hole for the ø25 series.
  - **Square Twin (Maintained):** The contact operates when ON button is pressed and is maintained in the depressed position. The button is reset by pressing the OFF button.
  - **Twin Maintained:** The contact operates when the top button is pressed and is maintained in the depressed position. The button is reset by pressing the bottom button.
- Different combinations of flush, extended HW9Z-A30 buttons, and colors are available (ABN1B-\*, ABN2B-\*). See page 65.  
 Mushroom buttons for the ABBN33 are ordered separately. Specify the color code (ABN3B-\*). See page 65.

# ø30 ø30 Series Pilot Lights

## Dome Pilot Lights

Package Quantity: 1

Shape	Lamp	Lamp Receptacle	Part No.	② Lens/LED Color Code	Applicable Lamp
Dome APN1 APNE1    	Without Lamp	BA9S	APN199②	C: clear DNA: amber DNY: yellow G: green O: orange R: red S: blue W: white	See pages 17 for lamps.
	LED	BA9S	APN1③DN②	A: amber G: green PW: pure white R: red S: blue W: white Y: yellow	
				A: amber G: green R: red S: blue W: white Y: yellow	

### Operating Voltage Code

Specify an operating voltage code in place of ③ in the Part No.

③ Operating Voltage Code	Input
66: 6V AC/DC 11: 12V AC/DC 22: 24V AC/DC	Full Voltage
16: 100/110V AC 126: 120V AC 26: 200/220V AC 246: 240V AC 386: 380V AC 46: 400/440V AC	Transformer
16D: 110V DC	DC-DC Converter *

- Specify a Lens/LED Color Code in place of ② in the Part No.
- Use a pure white (PW) LED for yellow (Y) illumination.

\* DC-DC converter types are not approved by UL and CSA, and not CE compliant (operating voltage 90 to 140V DC).

## Dimensions

### Full Voltage

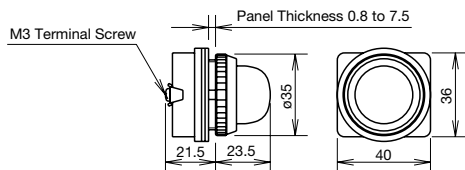

### Transformer



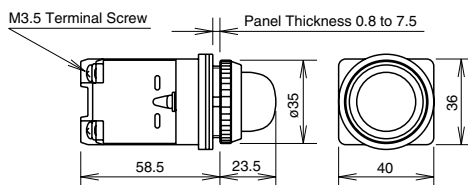

### DC-DC Converter



All dimensions in mm.

**Square / Rectangular (Marking) Pilot Lights**

Package Quantity: 1

Shape	Lamp	Lamp Receptacle	Part No.	② Lens/LED Color Code	Applicable Lamp
Square UPQN3B  	Without Lamp	BA9S	UPQN3B99②	DA: amber DY: yellow C: clear G: green O: orange R: red S: blue W: white	See pages 18 for lamps.
	LED	BA9S	UPQN3B③D②	A: amber G: green R: red S: blue W: white Y: yellow	
Rectangular (Marking) UPQN4  	Without Lamp	BA9S	UPQN499②	DA: amber DY: yellow G: green O: orange R: red S: blue W: white	
	LED	BA9S	UPQN4③D②	A: amber G: green R: red S: blue W: white Y: yellow	

**Operating Voltage Code**

Specify an operating voltage code in place of ③ in the Part No.

③ Operating Voltage Code	Input Type
66: 6V AC/DC 11: 12V AC/DC 22: 24V AC/DC	Full Voltage
16: 100/110V AC 126: 120V AC 26: 200/220V AC 246: 240V AC 386: 380V AC 46: 400/440V AC	Transformer
16D: 110V DC	DC-DC Converter *

- Specify a Lens/LED Color Code in place of ② in the Part No.
- Use a pure white (PW) LED for yellow (Y) illumination.
- On the rectangular marking pilot light, a clear lens and a color marking plate are used for white illumination.  
Marking plate: 24 × 30 mm, 2 mm thick

\* DC-DC converter types are not approved by UL and CSA, and not CE compliant (operating voltage 90 to 140V DC).

# ø30 ø30 Series Pilot Lights

## Dimensions

### Square Full Voltage UPQN3B

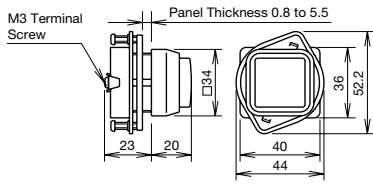

### Rectangular Full Voltage UPQN4

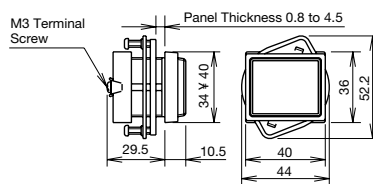

### Square Transformer Square DC-DC Converter UPQN3B

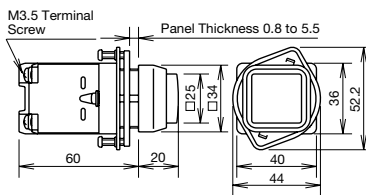

### Rectangular Transformer Rectangular DC-DC Converter UPQN4

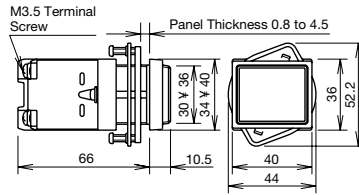

All dimensions in mm.

## Reflector

1. The lamp housing of the square LED illuminated pilot lights has a built-in reflector.
2. Make sure that the reflector does not fall off when removing the lens or marking plate.
3. When replacing the LED lamp of UPQNE4 (rectangular), use a lamp holder tool (OR-55).
4. To remove the reflector, insert a flat screwdriver inside the groove of the reflector and lightly push out.

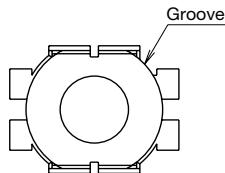

## Panel Mounting

1. Tighten the square ring to the operator and position the ring correctly.
2. Lightly tighten the screw to secure the pilot light onto the panel.

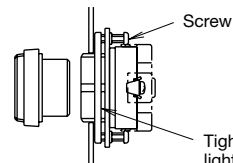



Tighten the screw lightly so that the panel does not bend.

Recommended tightening torque: 0.15 N·m

# ø30 Series Illuminated Pushbuttons ø30

## Round Extended Illuminated Pushbuttons

Package Quantity: 1

Shape	Lamp Receptacle	Operation	Lamp	Contact	Part No.	Applicable Lamp
Round Extended ALN2 AOLN2 ALNE2 AOLNE2    	BA9S	Momentary	Without Lamp	1NO-1NC	ALN29911DN <sup>②</sup>	See pages 17 for lamps.
				2NO	ALN29920DN <sup>②</sup>	
				2NC	ALN29902DN <sup>②</sup>	
			LED	1NO-1NC	ALN2 <sup>③</sup> 11DN <sup>②</sup>	
				2NO	ALN2 <sup>③</sup> 20DN <sup>②</sup>	
				2NC	ALN2 <sup>③</sup> 02DN <sup>②</sup>	
		Maintained	Without Lamp	1NO-1NC	AOLN29911DN <sup>②</sup>	
				2NO	AOLN29920DN <sup>②</sup>	
				2NC	AOLN29902DN <sup>②</sup>	
			LED	1NO-1NC	AOLN2 <sup>③</sup> 11DN <sup>②</sup>	
				2NO	AOLN2 <sup>③</sup> 20DN <sup>②</sup>	
				2NC	AOLN2 <sup>③</sup> 02DN <sup>②</sup>	

### Color Code and Operating Voltage Code

② Lens/LED Color Code	③ Operating Voltage Code	Input
Specify a Lens/LED Color Code in place of ②. A: amber G: green PW: pure white R: red S: blue W: white Y: yellow	66: 6V AC/DC 11: 12V AC/DC 22: 24V AC/DC  16: 100/110V AC 126: 120V AC 26: 200/220V AC 246: 240V AC 386: 380V AC 46: 400/440V AC	Full voltage  Transformer
Use a pure white (PW) LED for yellow (Y) illumination.		

### Dimensions

ALN2/AOLN2  
BA9S/Full Voltage

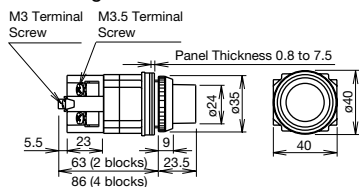

ALN2/AOLN2  
BA9S/Transformer

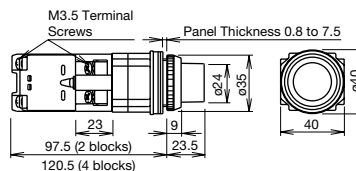



All dimensions in mm.

# ø30 ø30 series Illuminated Pushbuttons

## Round Extended with Half Shroud Illuminated Pushbuttons

Package Quantity: 1

Shape	Lamp Receptacle	Operation	Lamp	Contact	Part No.	Applicable Lamp
Round Extended ALGN2 AOLGN2 ALGNE2 AOLGNE2    	BA9S	Momentary	Without Lamp	1NO-1NC	ALGN29911DN②	See pages 17 for lamps.
				2NO	ALGN29920DN②	
				2NC	ALGN29902DN②	
			LED	1NO-1NC	ALGN2③11DN②	
				2NO	ALGN2③20DN②	
				2NC	ALGN2③02DN②	
		Maintained	Without Lamp	1NO-1NC	AOLGN29911DN②	
				2NO	AOLGN29920DN②	
				2NC	AOLGN29902DN②	
			LED	1NO-1NC	AOLGN2③11DN②	
				2NO	AOLGN2③20DN②	
				2NC	AOLGN2③02DN②	

### Color Code and Operating Voltage Code

Specify a code in place of ② or ③ in the Part No.

② Lens/LED Color Code	③ Operating Voltage Code	Input
Specify a Lens/LED Color Code in place of ②.	66: 6V AC/DC 11: 12V AC/DC 22: 24V AC/DC	Full voltage
A: amber G: green PW: pure white R: red S: blue W: white Y: yellow	16: 100/110V AC 126: 120V AC 26: 200/220V AC 246: 240V AC 386: 380V AC 46: 400/440V AC	Transformer
Use a pure white (PW) LED for yellow (Y) illumination.		

### Dimensions

ALFN2/AOLFN2  
BA9S/Full Voltage

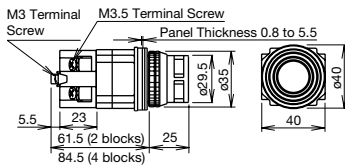

ALFN2/AOLFN2  
BA9S/Transformer

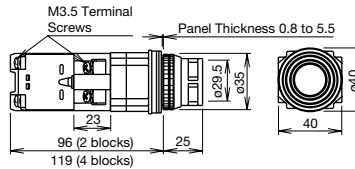



All dimensions in mm.

# ø30 Series Illuminated Pushbuttons ø30

## Round Extended with Half Shroud Illuminated Pushbuttons

Package Quantity: 1

Shape	Lamp Receptacle	Operation	Lamp	Contact	Part No.	Applicable Lamp
Round Extended ALFN2 AOLFN2 ALFNE2 AOLFNE2    	BA9S	Momentary	Without Lamp	1NO-1NC	ALFN29911DN②	See pages 17 for lamps.
				2NO	ALFN29920DN②	
				2NC	ALFN29902DN②	
			LED	1NO-1NC	ALFN2③11DN②	
				2NO	ALFN2③20DN②	
				2NC	ALFN2③02DN②	
		Maintained	Without Lamp	1NO-1NC	AOLFN29911DN②	
				2NO	AOLFN29920DN②	
				2NC	AOLFN29902DN②	
			LED	1NO-1NC	AOLFN2③11DN②	
				2NO	AOLFN2③20DN②	
				2NC	AOLFN2③02DN②	

### Color Code and Operating Voltage Code

Specify a code in place of ② or ③ in the Part No.

② Lens/LED Color Code	③ Operating Voltage Code	Input
Specify a Lens/LED Color Code in place of ②.	66: 6V AC/DC 11: 12V AC/DC 22: 24V AC/DC	Full voltage
A: amber G: green PW: pure white R: red S: blue W: white Y: yellow	16: 100/110V AC 126: 120V AC 26: 200/220V AC 246: 240V AC 386: 380V AC 46: 400/440V AC	Transformer
Use a pure white (PW) LED for yellow (Y) illumination.		

### Dimensions

ALFN2/AOLFN2  
BA9S/Full Voltage

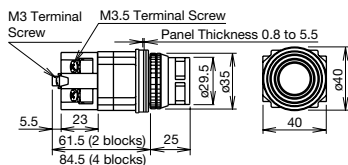

ALFN2/AOLFN2  
BA9S/Transformer

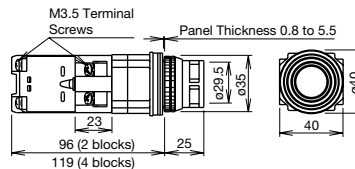





All dimensions in mm.

# ø30 ø30 series Illuminated Pushbuttons

## Mushroom (ø40) Illuminated Pushbuttons

Package Quantity: 1

Shape	Lamp Receptacle	Operation	Lamp	Contact	Part No.	Applicable Lamp
ø40 Mushroom ALN3 AOLN3 ALNE3 AOLNE3       	BA9S	Momentary	Without Lamp	1NO-1NC	ALN39911DN②	See pages 17 for lamps.
				2NO	ALN39920DN②	
				2NC	ALN39902DN②	
			LED	1NO-1NC	ALN3③11DN②	
				2NO	ALN3③20DN②	
				2NC	ALN3③02DN②	
		Maintained	Without Lamp	1NO-1NC	AOLN39911DN②	
				2NO	AOLN39920DN②	
				2NC	AOLN39902DN②	
			LED	1NO-1NC	AOLN3③11DN②	
				2NO	AOLN3③20DN②	
				2NC	AOLN3③02DN②	

### Color Code and Operating Voltage Code

Specify a code in place of ② or ③ in the Part No.

② Lens/LED Color Code	③ Operating Voltage Code	Input
Specify a Lens/LED Color Code in place of ②.  A: amber G: green R: red S: blue W: white Y: yellow  Use a pure white (PW) LED for yellow (Y) illumination.	66: 6V AC/DC 11: 12V AC/DC 22: 24V AC/DC  16: 100/110V AC 126: 120V AC 26: 200/220V AC 246: 240V AC 386: 380V AC 46: 400/440V AC	Full voltage  Transformer

### Dimensions

ALN3/AOLN3  
BA9S/Full Voltage

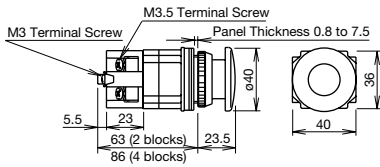

ALN3/AOLN3  
BA9S/Transformer

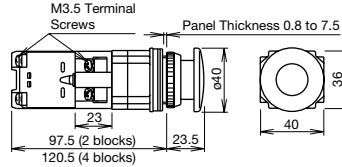







# ø30 Series Illuminated Pushbuttons ø30

## Pushlock Turn Reset/Push Turn Lock Illuminated Pushbuttons

Package Quantity: 1

Shape	Lamp Receptacle	Operation	Lamp	Contact	Part No.	Applicable Lamp
ø40 Mushroom Pushlock Turn Reset AVLN3 AVLNE3  	BA9S	Pushlock Turn Reset	Without Lamp	1NO-1NC	AVLN39911DNR	See pages 17 for lamps.
				2NO	AVLN39920DNR	
				2NC	AVLN39902DNR	
			LED	1NO-1NC	AVLN3③11DNR	
				2NO	AVLN3③20DNR	
				2NC	AVLN3③02DNR	
ø40 Mushroom Push Turn Lock AJLN3  	BA9S	Push Turn Lock	Without Lamp	1NO-1NC	AJLN39911DN②	
				2NO	AJLN39920DN②	
				2NC	AJLN39902DN②	
			LED	1NO-1NC	AJLN3③11DN②	
				2NO	AJLN3③20DN②	
				2NC	AJLN3③02DN②	

### Color Code and Operating Voltage Code

Specify a code in place of ② or ③ in the Part No.

② Lens/LED Color Code	③ Operating Voltage Code	Input
Specify a Lens/LED Color Code in place of ②.	66: 6V AC/DC 11: 12V AC/DC 22: 24V AC/DC	Full voltage
A: amber G: green R: red W: white Y: yellow	16: 100/110V AC 126: 120V AC 26: 200/220V AC 246: 240V AC 386: 380V AC 486: 400/440V AC	Transformer

- **Pushlock Turn Reset:** Lens is maintained when pressed and is reset when turned clockwise. Red lens only.  
 Note: AVNL3 and AVNLE3 pushlock turn reset switches cannot be used as emergency stop switches. When emergency stop switches are required, use XN or HN series emergency stop switches (ISO 13850 and IEC 60947-5-5 compliant).
- **Push Turn Lock:** Lens is maintained when turned clockwise in the depressed position and is reset when turned counterclockwise.

### Dimensions

#### AVLN3

#### BA9S/Full Voltage

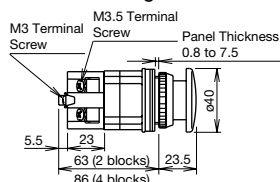

#### AVLN3

#### BA9S/Transformer

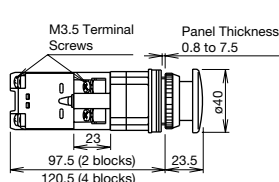

#### AJLN3

#### BA9S/Full Voltage

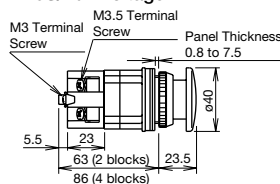

#### AJLN3

#### BA9S/Transformer

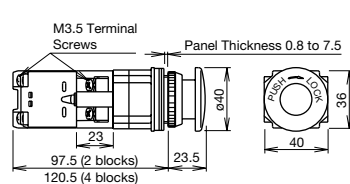

All dimensions in mm.

# ø30 ø30 Series Selector Switches

## ASN Selector Switches (Knob Operator)

Package Quantity: 1

ASN



- Knob: Black
- Round bezel (metal): Chrome-plated
- Units marked with ★ differ in shape. See page 40 for dimensions.
- When a terminal cover is required, order an applicable terminal cover referring to page 59.
- Nameplates are ordered separately.



	Contact Configuration	Contact Block		Operator Position		Maintained	Spring Return from Right	Maintained	Spring Return from Left		
		Mounting Position	Contact	L	R	L R	L R	L R	L R		
90° 2-position	1NO	1	NO	●		ASN310	ASN410	/	/		
		2	—								
	1NO-1NC	1	NO	●	●	ASN311	ASN411				
		2	NC								
	2NO	1	NO	●	●	ASN320	ASN420				
		2	NO	●	●						
	2NO-2NC	1	NO	●	●	ASN322	ASN422				
		2	NC	●	●						
		3	NO	●	●						
		4	NC	●	●						
1EM-1LB	1	EM	■	■	ASN37S (Note)	ASN47S (Note)					
	2	LB	■	■							
45° 3-position	1NO	1	NO	●		/	/	ASN3010	ASN4010		
		2	—								
	1NO-1NC	1	NO	●	●			ASN3011	ASN4011		
		2	NC								
	2NO	1	NO	●	●			ASN3020	ASN4020		
		2	NO	●	●						
	2NO-2NC	1	NO	●	●			ASN3022	ASN4022		
		2	NC	●	●						
		3	NO	●	●						
		4	NC	●	●						
1EM-1LB	1	EM	■	■	ASN307S (Note)	ASN407S (Note)					
	2	LB	■	■							
90° 2-position	1NO-1NC	1	NO	●		ASN111	ASN211	/	/		
		2	NC		●						
	2NO-2NC	1	NO	●		ASN122	ASN222				
		2	NC		●						
		3	NO	●							
		4	NC		●						
	2NO-2NC	1	NO	●		ASN15S ★	ASN25S ★				
		2	NO	●							
		3	NC		■						
		4	NC		■						
	2NC	1	NC		■	ASN17S ★	ASN27S ★				
		2	NC		■						
	4NC	1	NC		■	ASN18S ★	ASN28S ★				
		2	NC		■						
		3	NC		■						
		4	NC		■						
	1NO-1NC	1	NO	●		/	/			ASN1011	ASN2011
		2	NC		●						
	2NO-2NC	1	NO	●						ASN1022	ASN2022
		2	NC		●						
3		NO	●								
4		NC		●							
2NO-2NC	1	NO	●		ASN105S ★			ASN205S ★			
	2	NO	●								
	3	NC		■							
	4	NC		■							
2NC	1	NC		■	ASN107S ★			ASN207S ★			
	2	NC		■							
4NC	1	NC		■	ASN108S ★			ASN208S ★			
	2	NC		■							
	3	NC		■							
	4	NC		■							

Note: The overlapping time is shorter for left to right than right to left. Take overlapping time into consideration.

ø30 Series Selector Switches **ø30**

ASN-T Selector Switches (Knob Operator)

[Twin Rod Type]

Package Quantity: 1

ASN-T



- Knob: Black
- Round bezel (metal): Chrome-plated
- When a terminal cover is required, order an applicable terminal cover referring to page 31.
- Nameplates are ordered separately.



	Contact Configuration	Contact Block		Operator Position			Maintained	Spring Return from Left	Maintained	Spring Return from Right
		Mounting Position	Contact	L	C	R	L C R	L C R	L C R	L C R
45° 3-position	2NO	1	NO	●			ASN120-T	ASN220-T	/	/
		2	NO			●				
	4NO	1	NO	●			ASN140-T	ASN240-T		
		2	NO			●				
		3	NO	●						
	2NO	1	NO			●	/	/		
		2	NO	●						
	4NO	1	NO			●	/	/	/	ASN2040-T
		2	NO	●						
		3	NO			●				
			4	NO	●					

ASN-T are twin-rod units.

# ø30 ø30 Series Selector Switches

## ASN□L Selector Switches (Lever Operator)

Package Quantity: 1

ASN□L



- Lever: Black
- Round bezel (metal): Chrome-plated
- Units marked with ★ differ in shape. See page 40 for dimensions.
- When a terminal cover is required, order an applicable terminal cover referring to page 59.
- Nameplates are ordered separately.



	Contact Configuration	Contact Block		Operator Position			Maintained	Spring Return from Right	Maintained	Spring Return from Left
		Mounting Position	Contact	L	R		L R	L R	L R	L R
90° 2-position	1NO	1	NO		●		ASN3L10	ASN4L10	/	/
		2	—							
	1NO-1NC	1	NO		●		ASN3L11	ASN4L11		
		2	NC	●						
	2NO	1	NO		●		ASN3L20	ASN4L20		
		2	NO		●					
	2NO-2NC	1	NO		●		ASN3L22	ASN4L22		
		2	NC	●						
		3	NO		●					
	1EM-1LB	1	EM	■■■■			ASN3L7S (Note)	ASN4L7S (Note)		
2		LB	■■■■							
90° 2-position	1NO	1	NO	●		/	/	ASN30L10	ASN40L10	
		2	—							
	1NO-1NC	1	NO	●				ASN30L11	ASN40L11	
		2	NC		●					
	2NO	1	NO	●				ASN30L20	ASN40L20	
		2	NO		●					
	2NO-2NC	1	NO	●				ASN30L22	ASN40L22	
		2	NC		●					
		3	NO	●						
	1EM-1LB	1	EM	■■■■				ASN30L7S (Note)	ASN40L7S (Note)	
2		LB	■■■■							
45° 3-position	1NO-1NC	1	NO	●		ASN1L11	ASN2L11	/	/	
		2	NC							●
	2NO-2NC	1	NO	●		ASN1L22	ASN2L22			
		2	NC							●
		3	NO	●						
	2NO-2NC	1	NO	●		ASN1L5S ★	ASN2L5S ★			
		2	NO							●
		3	NC							●
		4	NC	■■■■						
	2NC	1	NC	■■■■			ASN1L7S ★			ASN2L7S ★
		2	NC	■■■■						
	4NC	1	NC	■■■■			ASN1L8S ★			ASN2L8S ★
		2	NC	■■■■						
		3	NC	■■■■						
		4	NC	■■■■						
	1NO-1NC	1	NO			ASN10L11	ASN20L11			
		2	NC	●						
	2NO-2NC	1	NO			ASN10L22	ASN20L22			
2		NC	●							
3		NO			●					
2NO-2NC	1	NO			ASN10L5S ★	ASN20L5S ★				
	2	NO	●							
	3	NC	■■■■							
	4	NC	■■■■							
2NC	1	NC	■■■■			ASN10L7S ★	ASN20L7S ★			
	2	NC	■■■■							
4NC	1	NC	■■■■			ASN10L8S ★	ASN20L8S ★			
	2	NC	■■■■							
	3	NC	■■■■							
	4	NC	■■■■							

Note: The overlapping time is shorter for left to right than right to left. Take overlapping time into consideration.

# ø30 Series Selector Switches ø30

## ASN□L-T Selector Switches (Lever Operator)

## [Twin Rod Type]

Package Quantity: 1

ASN□L-T



- Lever: Black
- Round bezel (metal): Chrome-plated
- When a terminal cover is required, order an applicable terminal cover referring to page 59.
- Nameplates are ordered separately.



	Contact Configuration	Contact Block		Operator Position			Maintained	Spring Return from Left	Maintained	Spring Return from Right		
		Mounting Position	Contact	L	C	R	L C R	L C R	L C R	L C R		
45° 3-position	2NO	1	NO	●			ASN1L20-T	ASN2L20-T	/	/		
		2	NO			●						
	4NO	1	NO	●			ASN1L40-T	ASN2L40-T				
		2	NO			●						
		3	NO	●								
	2NO	1	NO			●	/	/			/	ASN20L20-T
		2	NO	●								
	4NO	1	NO			●	/	/			/	/
		2	NO	●								
		3	NO			●						
			4	NO	●							ASN20L40-T

ASN□-T are twin-rod units.

# ø30 ø30 Series Selector Switches

## ASN□K Key Selector Switches

Package Quantity: 1

ASN□K

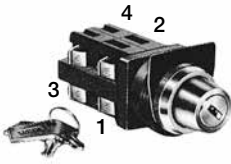

- Cylinder: Chrome-plated
- Round bezel (metal): Chrome-plated
- On spring-returned types, the keys can be released only from the maintained position. On maintained types, the key can be released from every position. Key retained positions are also available. See page 20.
- Key selector switch is supplied with two standard keys. Two different keys are available upon request.
- When a terminal cover is required, order an applicable terminal cover referring to page 59.
- Nameplates are ordered separately.

	Contact Configuration	Contact Block		Operator Position			Maintained	Spring Return from Right	Maintained	Spring Return from Left		
		Mounting Position	Contact	L	R		L R	L R	L R	L R		
90° 2-position	1NO	1	NO		●		ASN3K10	ASN4K10	/	/		
		2	—		—							
	1NO-1NC	1	NO	●		●	ASN3K11	ASN4K11				
		2	NC		●							
	2NO	1	NO			●	ASN3K20	ASN4K20				
		2	NO			●						
	2NO-2NC	1	NO	●		●	ASN3K22	ASN4K22				
		2	NC		●							
		3	NO	●		●						
		4	NC		●							
1EM-1LB	1	EM	■			ASN3K7S (Note)	ASN4K7S (Note)					
2	LB	■										
1NO	1	NO	●			/	/	ASN30K10	ASN40K10			
	2	—										
1NO-1NC	1	NO	●		●			ASN30K11	ASN40K11			
	2	NC		●								
2NO	1	NO	●					ASN30K20	ASN40K20			
	2	NO	●									
2NO-2NC	1	NO	●		●			ASN30K22	ASN40K22			
	2	NC		●								
	3	NO	●		●							
	4	NC		●								
1EM-1LB	1	EM	■			ASN30K7S (Note)	ASN40K7S (Note)					
2	LB	■										
45° 3-position	1NO-1NC	1	NO	●		●	ASN1K11	ASN2K11	/	/		
		2	NC			●						
	2NO-2NC	1	NO	●		●	ASN1K22	ASN2K22				
		2	NC			●						
		3	NO	●		●						
		4	NC			●						
	1NO-1NC 1EM-1LB	1	NO	●		●	ASN1K5S	ASN2K5S				
		2	NC			●						
		3	EM	■								
		4	LB	■								
	1EM-1LB	1	EM	■			ASN1K7S	ASN2K7S				
		2	LB	■								
	2EM-2LB	1	EM	■			ASN1K8S	ASN2K8S				
		2	LB	■								
		3	EM	■								
		4	LB	■								
	1NO-1NC	1	NO	●		●	/	/			ASN10K11	ASN20K11
		2	NC			●						
2NO-2NC	1	NO	●		●	ASN10K22			ASN20K22			
	2	NC			●							
	3	NO	●		●							
	4	NC			●							
1NO-1NC 1EM-1LB	1	NO	●		●	ASN10K5S			ASN20K5S			
	2	NC			●							
	3	EM	■									
	4	LB	■									
1EM-1LB	1	EM	■			ASN10K7S	ASN20K7S					
	2	LB	■									
2EM-2LB	1	EM	■			ASN10K8S	ASN20K8S					
	2	LB	■									
	3	EM	■									
	4	LB	■									

Note: The overlapping time is shorter for left to right than right to left. Take overlapping time into consideration.

ø30 Series Selector Switches ø30

ASN□K-T Key Selector Switches

[Twin Rod Type]

Package Quantity: 1

ASN□K-T



- Cylinder: Chrome-plated
- Round bezel (metal): Chrome-plated
- On spring-returned types, the keys can be released only from the maintained position.  
On maintained types, the key can be released from every position.
- Key retained positions are also available. See page 20.
- Key selector switch is supplied with two standard keys.  
Two different keys are available upon request.
- When a terminal cover is required, order an applicable terminal cover referring to page 59.
- Nameplates are ordered separately.



Contact Configuration	Contact Block		Operator Position			Maintained	Spring Return from Right	Maintained	Spring Return from Left	
	Mounting Position	Contact	L	R		L R	L R	L R	L R	
90° 2-position	1NO	1	NO		●		ASN3K10-T	ASN4K10-T	/	
		2	—	—						
	1NO-1NC	1	NO		●		ASN3K11-T	ASN4K11-T		
		2	NC	●						
	2NO	1	NO		●		ASN3K20-T	ASN4K20-T		
		2	NO		●					
	2NO-2NC	1	NO	●			ASN3K22-T	ASN4K22-T		
		2	NC		●					
		3	NO		●					
	1EM-1LB	1	EM	■			ASN3K7S-T	ASN4K7S-T		
		2	LB	■						
	1NO	1	NO	●			/	/		ASN40K10-T
2		—	—							
1NO-1NC	1	NO	●			ASN40K11-T				
	2	NC		●						
2NO	1	NO	●			ASN40K20-T				
	2	NO	●							
2NO-2NC	1	NO	●			ASN40K22-T				
	2	NC		●						
	3	NO	●							
1EM-1LB	1	EM	■			ASN40K7S-T				
	2	LB	■							
45° 3-position	2NO	1	NO	●					ASN1K20-T	ASN2K20-T
		2	NO		●					
	4NO	1	NO	●			ASN1K40-T	ASN2K40-T		
		2	NO		●					
		3	NO	●						
	2NO-2NC	1	NO	●			ASN1K5S-T	ASN2K5S-T		
		2	NO		●					
		3	NC	■						
	2NC	1	NC	■			ASN1K7S-T	ASN2K7S-T		
		2	NC	■						
	4NC	1	NC	■			ASN1K8S-T	ASN2K8S-T		
		2	NC	■						
		3	NC	■						
	2NO	1	NO	●			/	/	ASN20K20-T	
		2	NO		●					
	4NO	1	NO	●					ASN20K40-T	
		2	NO		●					
		3	NO	●						
	2NO-2NC	1	NO	●					ASN20K5S-T	
		2	NO		●					
3		NC	■							
2NC	1	NC	■			ASN20K7S-T				
	2	NC	■							
4NC	1	NC	■			ASN20K8S-T				
	2	NC	■							
	3	NC	■							
4NC	1	NC	■							
	2	NC	■							
4NC	3	NC	■							
	4	NC	■							

ASN-T are twin-rod units.

# ø30 ø30 Series Selector Switches

## Dimensions

### Knob Operator

Dimensions of knob operator marked with ★ or "-T" in the Part No.

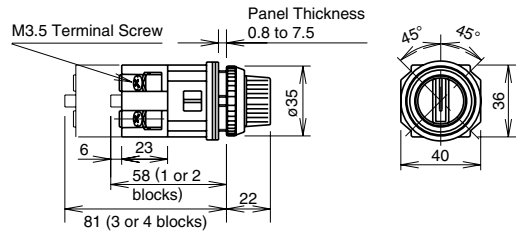
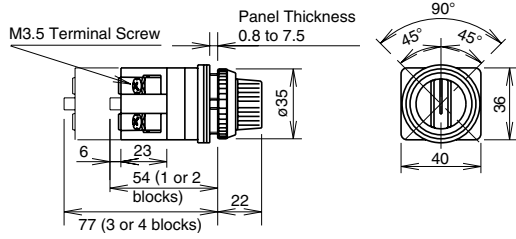

### Lever Operator

Dimensions of lever operator marked with ★ or "-T" in the Part No.

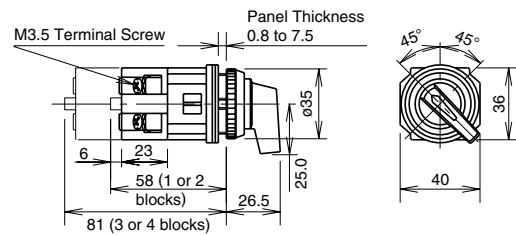
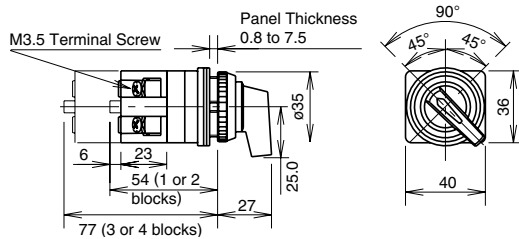

### Key Selector

Dimensions of key selector switches marked with "-T" in the Part No.

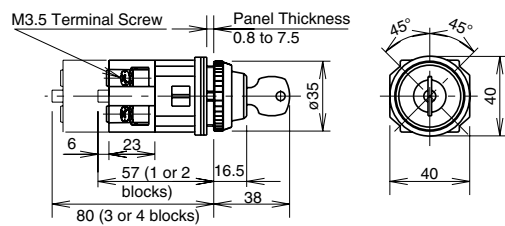
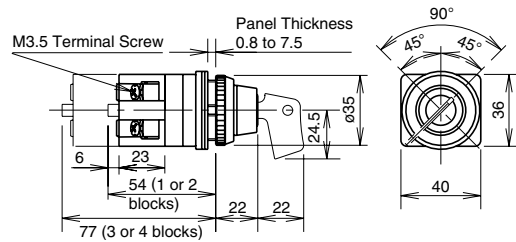

All dimensions in mm.

## Contact Block Mounting Position and Contact Configuration Chart



		Left	Center	Right	
		L	C	R	← Operator position
1	NO	●			
2	NO			●	
3	NC		■		
4	NC	■			



# ø30 Series Selector Switches ø30

## ASTN Selector Switches (Knob Operator)

Package Quantity: 1

No. of Positions	ASTN		• Knob operator: Black • Round bezel (metal): Chrome-plated							
										
		UL LISTED		CE		CCC				
90° 2-position	Contact Configuration	Contact Block		Operator Position		Maintained	Spring Return from Right	—	—	
		Mounting Position	Contact	L	R			—	—	
	1NO-1NC	1	NO		●	ASTN3211	ASTN4211	—	—	
		2	NC	●						
	2NO-2NC	1	NO		●	ASTN3222	ASTN4222	—	—	
2		NO		●						
	3	NC	●							
	4	NC	●							
45° 3-position	Contact Configuration	Contact Block		Operator Position			Maintained	Spring Return from Left	Spring Return from Right	Spring Return Two-way
		Mounting Position	Contact	L	C	R				
	2NO	1	NO	●			—	—	—	ASTN5120
		2	NO			●				
	2NO-2NC	1	NO	●			ASTN1122	ASTN2122	ASTN20122	ASTN5122
		2	NO			●				
		3	NC			●				
		4	NC			●				
	2NO-2NC	1	NO	●			ASTN1222	ASTN2222	ASTN20222	ASTN5222
		2	NO			●				
		3	NC			●				
		4	NC			●				
	4NO	1	NO	●			ASTN1340	—	—	—
		2	NO			●				
		3	NO	●						
		4	NO			●				
	2NO-2NC	1	NO	●			ASTN1422	—	ASTN20422	—
		2	NC			●				
		3	NC			●				
		4	NO			●				
	2NO	1	NO	●			ASTN1520	—	ASTN20520	—
		2	NO			●				
	4NO	1	NO	●			ASTN1540	—	ASTN20540	—
		2	NO			●				
		3	NO	●						
		4	NO			●				
	1NO-1NC	1	NC			●	ASTN1611	—	—	—
		2	NO			●				
2NO-2NC	1	NC			●	ASTN1622	—	—	—	
	2	NO			●					
	3	NC			●					
	4	NO			●					
1NO-1NC	1	NO	●			—	—	—	ASTN5111	
	2	NC			●					

**Notes:**

1. The operator of the 2-way spring return unit may slightly deviate from the center position.
2. Turn the operator to each position accurately.

**Contact Block Mounting Position and Contact Configuration Chart**



		Left	Center	Right	Operator Position
		L	C	R	
1	NO	●			
2	NO			●	
3	NC			●	
4	NC	●			



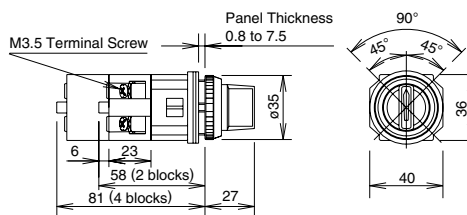





**Dimensions**



# ø30 ø30 Series Selector Switches

## ASTN□L Selector Switches (Lever Operator)

Package Quantity: 1

No. of Positions	ASTN□L		<ul style="list-style-type: none"> <li>Lever operator: Black</li> <li>Round bezel (metal): Chrome-plated</li> </ul>							
										
90° 2-position	Contact Configuration	Contact Block		Operator Position		Maintained	Spring Return from Right	—	—	
		Mounting Position	Contact	L	R			—	—	
	1NO-1NC	1	NO	●	●	ASTN32L11	ASTN42L11	—	—	
		2	NC	●						
2NO-2NC	1	NO		●	ASTN32L22	ASTN42L22				
	2	NO		●						
	3	NC	●							
	4	NC	●							
45° 3-position	Contact Configuration	Contact Block		Operator Position			Maintained	Spring Return from Left	Spring Return from Right	Spring Return Two-way
		Mounting Position	Contact	L	C	R				
	2NO	1	NO	●			—	—	—	ASTN51L20
		2	NO			●				
	2NO-2NC	1	NO	●			ASTN11L22	ASTN21L22	ASTN201L22	ASTN51L22
		2	NO			●				
		3	NC			●				
		4	NC	●						
	2NO-2NC	1	NO	●			ASTN12L22	ASTN22L22	ASTN202L22	ASTN52L22
		2	NO			●				
		3	NC			●				
		4	NC	●						
	4NO	1	NO	●			ASTN13L40	—	—	—
		2	NO			●				
		3	NO	●						
		4	NO			●				
	2NO-2NC	1	NO	●			ASTN14L22	—	ASTN204L22	—
		2	NC			●				
		3	NC			●				
		4	NO			●				
2NO	1	NO	●			ASTN15L20	—	ASTN205L20	—	
	2	NO			●					
4NO	1	NO	●			ASTN15L40	—	ASTN205L40	—	
	2	NO			●					
	3	NO	●							
	4	NO			●					
1NO-1NC	1	NC			●	ASTN16L11	—	—	—	
	2	NO			●					
2NO-2NC	1	NC			●	ASTN16L22	—	—	—	
	2	NO			●					
	3	NC			●					
	4	NO			●					
1NO-1NC	1	NO	●			—	—	—	ASTN51L11	
	2	NC			●					

**Notes:**

- The operator of the 2-way spring return unit may slightly deviate from the center position.
- Turn the operator to each position accurately.

**Contact Block Mounting Position and Contact Configuration Chart**







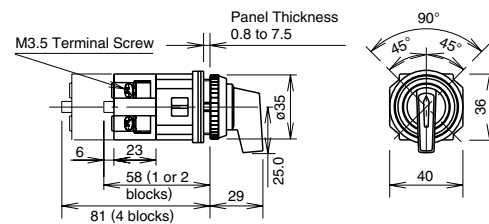

		Left	Center	Right	Operator Position
		L	C	R	
1	NO	●			
2	NO			●	
3	NC			●	
4	NC	●			

**Dimensions**



**ASTN□K Key Selector Switches**

Package Quantity: 1

No. of Positions	ASTN□K		<ul style="list-style-type: none"> <li>• Cylinder: Chrome-plated</li> <li>• Round bezel (metal): Chrome-plated</li> <li>• On the spring-returned, the keys can be released only from the maintained position.</li> <li>• On the maintained, the key can be released from every position. Key retained positions are also available. See page 20.</li> </ul>							
										
90° 2-position	Contact Configuration	Contact Block	Operator Position			Maintained	Spring Return from Right	—	—	
		Mounting Position	Contact	L	R			—	—	
	1NO-1NC	1	NO	●	●	ASTN32K11	ASTN42K11	—	—	
		2	NC	●						
	2NO-2NC	1	NO	●	●	ASTN32K22	ASTN42K22	—	—	
2		NO		●						
3		NC	●							
4	NC	●								
45° 3-position	Contact Configuration	Contact Block	Operator Position			Maintained	Spring Return from Left	Spring Return from Right	Spring Return Two-way	
		Mounting Position	Contact	L	C	R				
	2NO	1	NO	●			—	—	—	ASTN51K20
		2	NO			●				
	2NO-2NC	1	NO	●			ASTN11K22	ASTN21K22	ASTN201K22	ASTN51K22
		2	NO			●				
		3	NC			●				
	4	NC	●							
	2NO-2NC	1	NO	●			ASTN12K22	ASTN22K22	ASTN202K22	ASTN52K22
		2	NO			●				
		3	NC			●				
	4	NC	●							
	4NO	1	NO	●			ASTN13K40	—	—	—
		2	NO			●				
		3	NO	●						
		4	NO			●				
	2NO-2NC	1	NO	●			ASTN14K22	—	ASTN204K22	—
		2	NC			●				
		3	NC			●				
	4	NO			●					
	2NO	1	NO			●	ASTN15K20	—	ASTN205K20	—
		2	NO	●						
	4NO	1	NO	●			ASTN15K40	—	ASTN205K40	—
		2	NO			●				
		3	NO	●						
		4	NO			●				
	1NO-1NC	1	NC			●	ASTN16K11	—	—	—
		2	NO			●				
2NO-2NC	1	NC			●	ASTN16K22	—	—	—	
	2	NO			●					
	3	NC			●					
4	NO			●						
1NO-1NC	1	NO	●			—	—	—	ASTN51K11	
	2	NC			●					

Notes:

1. The operator of the 2-way spring return unit may slightly deviate from the center position.
2. Turn the operator to each position accurately.

**Contact Block Mounting Position and Contact Configuration Chart**



	Left	Center	Right	Operator Position
	L	C	R	
1	NO	●		
2	NO		●	
3	NC		●	
4	NC	●		

**Dimensions**

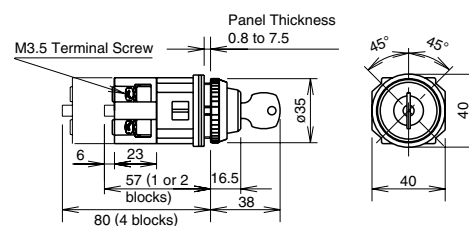

# ø30 ø30 series Illuminated Selector Switches

## ASLN Illuminated Selector Switches

90° 2-position

Package Quantity: 1

ASLN (Base BA9S)



Contact Configuration	Contact Block		Operator Position		Lamp	Maintained L R	Spring Return from Right L R	Spring Return from Left L R
	Mounting Position	Contact	L	R				
1NO-1NC	1	NO		●	Without Lamp	ASLN29911N②	ASLN219911N②	ASLN229911N② *
	2	NC	●		LED	ASLN2③11DN②	ASLN21③11DN②	ASLN22③11DN② *
2NO	1	NO		●	Without Lamp	ASLN29920N②	ASLN219920N②	ASLN229920N② *
	2	NO		●	LED	ASLN2③20DN②	ASLN21③20DN②	ASLN22③20DN② *
2NO-2NC	1	NO		●	Without Lamp	ASLN29922N②	ASLN219922N②	ASLN229922N② *
	2	NC	●					
	3	NO		●	LED	ASLN2③22DN②	ASLN21③22DN②	ASLN22③22DN② *
	4	NC	●					

### Color Code and Operating Voltage Code

Specify a code in place of ② or ③ in the Part No.

② Lens/LED Color Code	③ Operating Voltage Code	Input
A: amber G: green R: red S: blue W: white Y: yellow	66: 6V AC/DC 11: 12V AC/DC 22: 24V AC/DC	Full voltage
Use a pure white (PW) LED for yellow (Y) illumination.	16: 100/110V AC 136: 120V AC 26: 200/220V AC 256: 240V AC 386: 380V AC 46: 400/440V AC	Transformer

On the 2-position selector switches marked with \* above, the contact operation is reversed as follows.

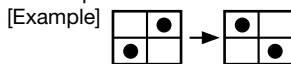

### Contact Block Mounting Position and Contact Configuration Chart

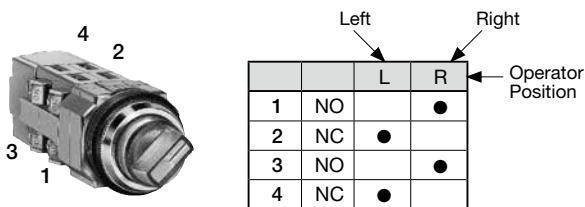

### Dimensions

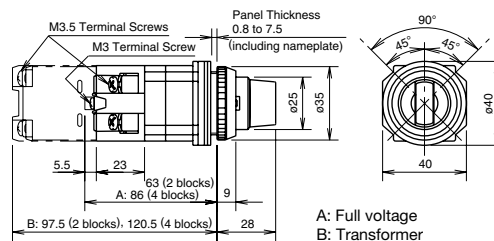

# ø30 Series Illuminated Selector Switches ø30

## ASLN Illuminated Selector Switches

45° 3-position

Package Quantity: 1

Contact Configuration	Contact Block		Operator Position			Lamp	Maintained	Spring Return from Right	Spring Return from left	Spring Return Two-way
	Mounting Position	Contact	L	C	R					
2NO	1	NO	●			Without Lamp	ASLN39920N②	ASLN319920N②	ASLN329920N②	ASLN339920N②
	2	NO			●	LED	ASLN3③20DN②	ASLN31③20DN②	ASLN32③20DN②	ASLN33③20DN②
2NC	1	NC		■		Without Lamp	ASLN39902N②	ASLN319902N②	ASLN329902N②	ASLN339902N②
	2	NC		■		LED	ASLN3③02DN②	ASLN31③02DN②	ASLN32③02DN②	ASLN33③02DN②
2NO-2NC	1	NO	●			Without Lamp	ASLN39922N②	ASLN319922N②	ASLN329922N②	ASLN339922N②
	2	NO			●					
	3	NC		■		LED	ASLN3③22DN②	ASLN31③22DN②	ASLN32③22DN②	ASLN33③22DN②
	4	NC		■						
4NO	1	NO	●			Without Lamp	ASLN39940N②	ASLN319940N②	ASLN329940N②	ASLN339940N②
	2	NO			●					
	3	NO	●			LED	ASLN3③40DN②	ASLN31③40DN②	ASLN32③40DN②	ASLN33③40DN②
	4	NO			●					
4NC	1	NC		■		Without Lamp	ASLN39904N②	ASLN319904N②	ASLN329904N②	ASLN339904N②
	2	NC		■						
	3	NC		■		LED	ASLN3③04DN②	ASLN31③04DN②	ASLN32③04DN②	ASLN33③04DN②
	4	NC		■						

### Color Code and Operating Voltage Code

Specify a code in place of ② or ③ in the Part No.

② Lens/LED Color Code	③ Operating Voltage Code	Input
A: amber G: green R: red S: blue W: white Y: yellow	66: 6V AC/DC 11: 12V AC/DC 22: 24V AC/DC	Full voltage
Use a pure white (PW) LED for yellow (Y) illumination.	16: 100/110V AC 136: 120V AC 26: 200/220V AC 256: 240V AC 386: 380V AC 46: 400/440V AC	Transformer

### Contact Block Mounting Position and Contact Configuration Chart

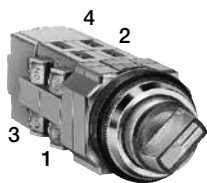

	Left	Center	Right	Operator Position
1	NO	●		
2	NO		●	
3	NC		■	
4	NC	■		

### Dimensions

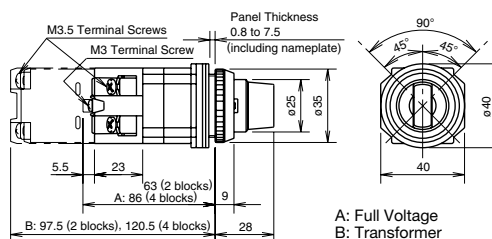

# ø30 ø30 series Selector Pushbuttons

## ABN Ring Operator / ABN□L Lever Operator Selector Pushbuttons

Package Quantity: 1

Shape	Contact Configuration	Circuit Code	Contact Block		Ring/Lever				Ring Operator	Lever Operator	① Button Color Code	
					Pushbutton							Part No.
					Mounting Position	Contact	Normal	Push	Normal	Push		
<b>ABN</b> <p>Ring Operator (90° 2-position)</p> <p>M3.5 Terminal Screw Panel Thickness 0.8 to 7.5 (including nameplate)</p> <b>ABN□L</b> <p>Lever Operator (90° 2-position)</p> <p>M3.5 Terminal Screw Panel Thickness 0.8 to 7.5 (including nameplate)</p>	1NO-1NC	A	1	NO		●		●	ABN6111①	ABN6L111①	B: black G: green R: red Y: yellow	
			2	NC	●							
		I	1	NC	●			■		ABN6411①		ABN6L411①
			2	NO		●			■			
		G	1	NO			Blocked		●	ABN9111①		ABN9L111①
			2	NC	●			●				
	2NO	D	1	NO				●	ABN7120①			
			2	NO				●				
		2NO-2NC	B	1	NC	●				ABN6122①		ABN6L122①
				2	NC	●						
				3	NO		●		●			
				4	NO		●		●			
C			1	NC	●					ABN6222①	ABN6L222①	
			2	NC	■							
		3	NO		●		●					
		4	NO				●					
I		1	NC	●					ABN6422①	ABN6L422①		
		2	NC	●								
		3	NO		●		■					
		4	NO		●		■					
D		1	NC	●			■		ABN7122①	ABN7L122①		
		2	NC	■			●					
		3	NO		●							
		4	NO				●					
E		1	NC				■		ABN7222①	ABN7L222①		
		2	NC	■								
	3	NO		●								
	4	NO				●						
F	1	NC				●		ABN7322①	ABN7L322①			
	2	NC	●									
	3	NO		●								
	4	NO				●						
H	1	NC	●			●		ABN9122①	ABN9L122①			
	2	NC	●			●						
	3	NO			Blocked		●					
	4	NO					●					

- Specify a button color code in place of ① in the Part No.
- Ring/Lever (metal): Chrome-plated

### Notes

1. Circuit Codes A, B, C, and I: When the ring or lever operator is turned, the button is pushed in.
2. Circuit Codes E and F: The right and left NC contact blocks on circuit code E or F may overlap each other while turning the ring or lever operator. The NO and NC contact blocks on circuit code F may overlap each other while pressing the button.
3. Circuit Codes G and H: The pushbutton does not operate when the ring or lever operator is turned to the left position.
4. When using the selector pushbutton, do not turn the ring or lever operator with the pushbutton depressed. Otherwise, damage or failure may be caused.

### Contact Block Mounting Position

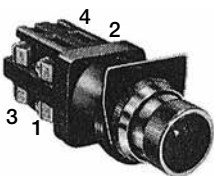

### Mounting Hole Layout

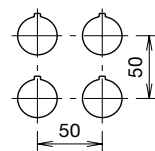

Ring Operator

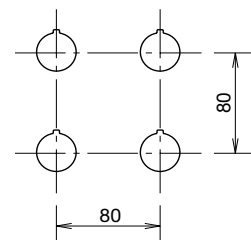

Lever Operator



# ø30 ARN/ARNS Series Mono-lever Switches

## Single lever offers up to four directions of control

Mono-lever switches operate in four directions using a single lever. Switch contacts are actuated in the direction in which the lever is pushed, enabling quick and accurate control in any desired direction. Ideal for machine tools and industrial machines. The lever action can be maintained or spring-returned in any combination.

Also available with interlock mechanism to prevent inadvertent actuation.



Applicable Standards	Mark	File No. or Organization
UL 508		UL Listing File No. E68961
CSA C22.2 No.14		CSA File No. LR21451
GB14048.5		CCC No.2013010305661112

## Specifications and Ratings

### Contact Ratings

Contact Block	BR
Rated Insulation Voltage	600V
Rated Continuous Current	10A
Contact Ratings by Utilization Category IEC 60947-5-1	AC-15 (A600) DC-13 (P600)

### Characteristics

#### Contact Ratings by Utilization Category

Operational Voltage		24V	48V	50V	110V	220V	440V	
Operational Current	AC 50/60 Hz	AC-12 Control of resistive loads and solid state loads	10A	—	10A	10A	6A	2A
		AC-15 Control of electromagnetic loads (> 72 VA)	10A	—	7A	5A	3A	1A
	DC	DC-12 Control of resistive loads and solid state loads	10A	5A	—	2.2A	1.1A	—
		DC-13 Control of electromagnets	4A	2A	—	1.1A	0.6A	—

Note: The operational current represents the classification by making and breaking currents (IEC 60947-5-1).

### Specifications

Contact Configuration	Double-break slow action Each contact block contains two independent contacts (2NO, 1NO-1NC, 2NC) Up to four contact blocks can be mounted
Operating Temperature	-25 to +50°C (no freezing)
Storage Temperature	-35 to +80°C (no freezing)
Operating Humidity	45 to 85% RH (no condensation)
Insulation Resistance	100 MΩ minimum (500V DC megger)
Dielectric Strength	Between live and dead parts: 2,500V AC, 1 minute
Mechanical Life	500,000 operations minimum
Electrical Life	(Interlocking: 250,000 operations minimum)
Lever Knob	Black
Weight (approx.)	276g (ARN4-1111-20202020)

### BR Contact Block





The contact block is made of nylon resin. Each contact block contains two pairs of double-break silver contacts. There are three types as shown in the diagram below and up to four contact blocks can be mounted in any direction. A wide variety of circuits allows diverse combinations of control.

### Control Mechanism

When the operator lever is pushed to about 30° in each direction from the neutral position, the contact in that direction activates. The lever can operate in two, three, or four directions, and combinations of maintained or spring-return from any position are possible.

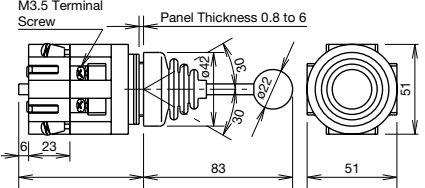
# ø30 ARN/ARNS Series Mono-lever Switches

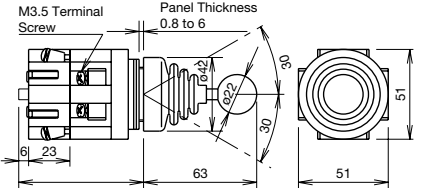
## Mono-lever Switches

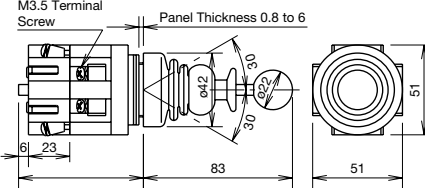
Operator	Position	Lever Action	Part No.	Dimensions (mm)
 ARN (Long Lever)	2-position (Up-Down)	Maintained	ARN2-1010-④B	 M3.5 Terminal Screw, Panel Thickness 0.8 to 6 1 block: 47, 2 blocks: 70 3 blocks: 93, 4 blocks: 116 Minimum horizontal/vertical mounting centers: 110
		Spring return	ARN2-2020-④B	
	2-position (Left-Right)	Maintained	ARN2-0101-④B	
		Spring return	ARN2-0202-④B	
	4-position (Up-Down-Left-Right)	Maintained	ARN4-1111-④B	
		Spring return	ARN4-2222-④B	
 ARNS (Short Lever)	2-position (Up-Down)	Maintained	ARNS2-1010-④B	 M3.5 Terminal Screw, Panel Thickness 0.8 to 6 1 block: 47, 2 blocks: 70 3 blocks: 93, 4 blocks: 116 Minimum horizontal/vertical mounting centers: 70
		Spring return	ARNS2-2020-④B	
	2-position (Left-Right)	Maintained	ARNS2-0101-④B	
		Spring return	ARNS2-0202-④B	
	4-position (Up-Down-Left-Right)	Maintained	ARNS4-1111-④B	
		Spring return	ARNS4-2222-④B	
 ARNL (Interlocking) The operator lever is locked only in the center position.	2-position (Up-Down)	Maintained	ARNL2-1010-④B	 M3.5 Terminal Screw, Panel Thickness 0.8 to 6 1 block: 47, 2 blocks: 70 3 blocks: 93, 4 blocks: 116 Minimum horizontal/vertical mounting centers: 110
		Spring return	ARNL2-2020-④B	
	2-position (Left-Right)	Maintained	ARNL2-0101-④B	
		Spring return	ARNL2-0202-④B	
	4-position (Up-Down-Left-Right)	Maintained	ARNL4-1111-④B	
		Spring return	ARNL4-2222-④B	

Specify Contact Configuration from the table below in place of ④.  
Terminal covers are ordered separately.

### Lever Operator Position

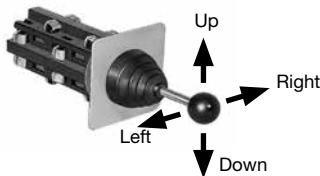

### Panel Cut-Out

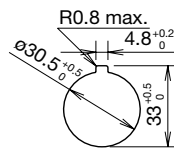

### Mono-Lever with Terminal Cover

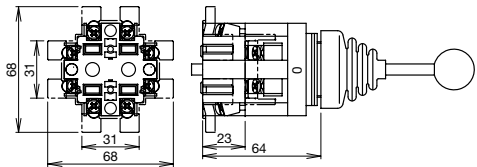

## Ordering Information

When ordering, specify items ① to ⑤ according to the following example.

[Example] ① ARN ② 4 - ③ 1012 - 2 0 0 0 2 1 1 ④ B

Up Right Down Left

① Model	② No. of Contact Blocks	③ Lever Action	④ Contact Arrangement	⑤ Lever Knob Color
ARN ARNS ARNL	1: 1 block 2: 2 blocks 3: 3 blocks 4: 4 blocks	Order of Entry: Up→Right→ Down→Left  1: Maintained 2: Spring return 0: Blocked	Order of Entry: Up→Right→ Down→Left  10: 1NO 01: 1NC 11: 1NO-1NC 20: 2NO 02: 2NC 00: Blocked	B: black

Contact Block Position	Terminal No.	Direction of Lever Operation				Terminal No.	Contact Block Type
		Lever Operation Mode					
		1	0	1	2		
1	1	NO	-	-	-	2	BR-2E
	3	-	-	NC	-	4	
2	5	-	NO *	-	-	6	BR-1E
	7	-	-	-	NO	8	
3	9	NO	-	-	-	10	BR-2E
	11	-	-	NC	-	12	
4	13	-	NC *	-	-	14	BR-3E
	15	-	-	-	NC	16	

\*: Contacts marked with \* do not operate.

- To calculate the number of contact blocks required, add the number of NO and NC contacts on each pair of adjoining positions (up + right, right + down, down + left, and left + up). The largest of the four sums is the number of contact blocks required. Up to four contact blocks can be mounted.







- Specify the same number of contacts for the contact blocks of opposing corner (up-down, right-left), except for the blocked direction.
- When UL and CSA markings are required on the mono-lever switch, specify as shown below.

[Example] ARN4-1012-20000211B-U

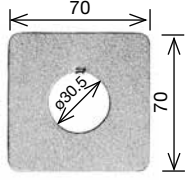

# ARN/ARNS Series Accessories and Replacement Parts ø30

## Accessories and Maintenance Parts

Shape	Specification	Part No.	Ordering No.	Package Quantity	Description
Nameplate		MLO	MLO	1	Chrome-plated brass (matte surface)
			MLOPN10	10	
Terminal Cover		ARN-VL2	ARN-VL2	1	Terminal covers are ordered separately. When ordering, specify the Part No. and the required quantity. Order 2 pieces for each contact block.
Contact Block (BR)		BR-1E	BR-1E	1	2NO contact
		BR-2E	BR-2E	1	1NO-1NC contact
		BR-3E	BR-3E	1	2NC contact
Bellows		ARN-BL	ARN-BL	1	For ARN/ARNS (Locking ring not included)
Bellows (Interlocking)		ARNL-BL	ARNL-BL	1	For ARNL (Locking ring not included)
Knob		ARNB-①	ARNB-①	1	Specify a color code in place of ①. B (black), G (green), R (red) For ARN/ARNS

# ø30/ø25 CS series Cam Switches

## 71 standard circuits to choose from

- Wide variety of heavy-duty oiltight cam switches
- Operators available up to 12 positions
- Contact blocks rated at 600V, 10A
- Ideal for ammeter/voltmeter applications
- UL listed and CSA approved

Applicable Standards	Mark	File No. or Organization
GB14048.5		CCC No.2012010305525956 (ACSNO, ACSNK) No.2013010305604910 (ACSSO, ACSSK) No.2013010305600565 (UCSQO, UCSQM)



(except ACSSO and ACSSK)

## Specifications and Ratings

### Contact Ratings

Rated Insulation Voltage	600V
Rated Continuous Current	10A
Contact Ratings by Utilization Category IEC 60947-5-1	AC-15 (A600) DC-13 (P600)

### Characteristics

#### Contact Ratings by Utilization Category

Operational Voltage		24V	110V	220V	440V	
Operational Current	AC 50/60 Hz	AC-12 Control of resistive loads and solid state loads	—	10A	6A	2A
		AC-15 Control of electromagnetic loads (> 72 VA)	—	5A	3A	1A
	DC	DC-12 Control of resistive loads and solid state loads	8A	3A	1A	0.4A
		DC-13 Control of electromagnets	5A	1.2A	0.45A	0.2A

Note: The operational current represents the classification by making and breaking currents (IEC 60947-5-1).

### Specifications

Contact Configuration	Double-break slow action contacts Two contacts in one deck Up to 6 decks available (Spring-return: Up to 3 decks)	
Operation	Maintained	Spring return
Angle	30°, 45°, 60°, 90°	45°
Operator Positions	2 to 12	2, 3, 4
Operating Temperature	-20 to +50°C (no freezing)	
Storage Temperature	-40 to +80°C (no freezing)	
Operating Humidity	45 to +85% RH (no condensation)	
Insulation Resistance	100 MΩ (500V DC megger)	
Dielectric Strength	2500V AC, 1 minute (between live and dead parts)	
Mechanical Life	1 to 3 decks: 500,000 operations 4 to 6 decks: 200,000 operations	
Electrical Life	200,000 operations minimum	
Degree of Protection	ACSNO, ACSSO: IP65 (IEC 60529) ACSNK, ACSSK: IP54 (IEC 60529) UCS: IP40 (IEC 60529)	
Weight (approx.)	319g (ACSNO-663-S2B)	



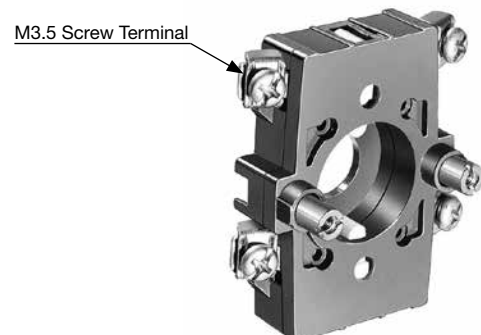

### CSB Contact Block

The CSB contact block contains two poles of double-break contacts. The contacts are operated by a cam designed to perform a required contact operation. Up to six contact blocks can be mounted on a maintained-action operator base, and up to three contact blocks on a spring return operator base.

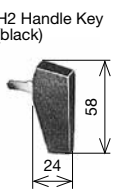

# CS Series Cam Switches ø30/ø25

## Cam Switches

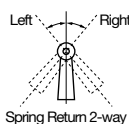
① Model		② Contact Block Decks	③ Positions	④ Angle	⑤ Spring Return	⑥ Handle	⑦ Contact Arrangement	Nameplate
ø30 Series	ø25 Series							
ACSNO	ACSSO	Maintained: 1 to 6 decks Spring return: 1 to 3 decks	Maintained: 2 to 12 positions Spring return: 2 to 4 positions	Maintained: 30°, 45°, 60°, 90° Spring return: 45° only	Spring return from right Spring return from left Spring return two-way	Y2, S2, P2, F2, 25S2 (25S2 is for ACSSO only) (one specified handle supplied)		See page 61. (ordered separately)
 <p>(Photo: ACSNO with Y2 handle)</p>								
ACS NK	ACSSK	Maintained: 1 to 6 decks Spring return: 1 to 3 decks	Maintained: 2 to 8 positions Spring return: 2 to 4 positions	Maintained: 45°, 90° Spring return: 45° only	Spring return from right Spring return from left Spring return two-way	Two standard keys are supplied. When the H2 key handle is required, specify H2.	See page 55 to 57.	
 <p>Standard Key (2 keys supplied)</p>  <p>H2 Handle Key (black)</p>								
UCSQO	(Enclosed)	Maintained: 1 to 6 decks Spring return: 1 to 3 decks	Maintained: 2 to 12 positions Spring return: 2 to 4 positions	Maintained: 30°, 45°, 60°, 90° Spring return: 45° only	Spring return from right Spring return from left Spring return two-way	Y2, S2, F2, P2 (one specified handle supplied)		Type CQ See page 60.
 <p>(Photo: With Y2 handle)</p>								
UCSQM	(Enclosed)	Spring return: 1 to 3 decks	Spring return: 3 positions	Spring return: 45° only	Spring return two-way		C1007 C1008 C1009 C1010 C1018 C2006 C2007 C2021 See page 55 to 57.	Type CQM See page 60.
 <p>Indicator Left: Green Right: Red</p>  <p>Left Right Spring Return 2-way</p>								

For handles and accessories, see page 52 and 53.

### Dimensions ACSNO/ACSSO

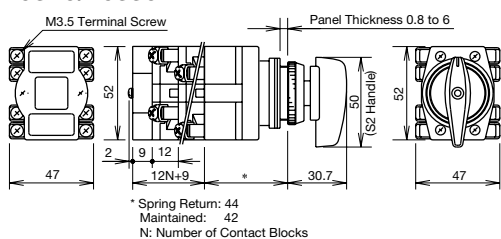

### ACS NK/ACSSK

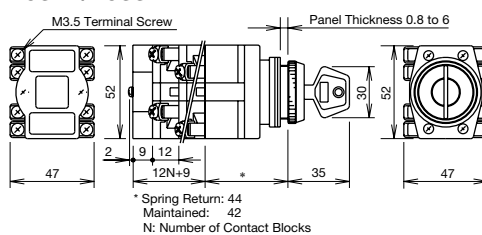

### Panel Cut-out

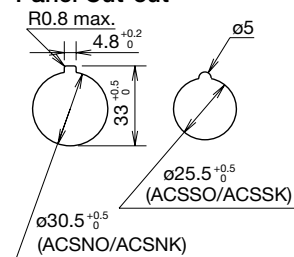

- Minimum horizontal/vertical mounting centers  
With P2 handle: 125  
With other handles: 70

### UCSQO

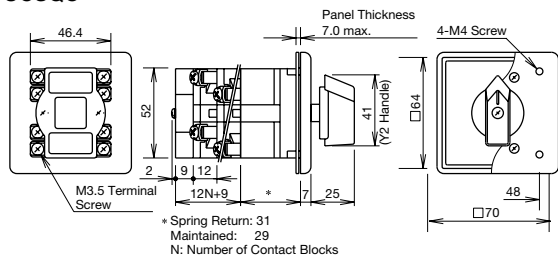

### UCSQM

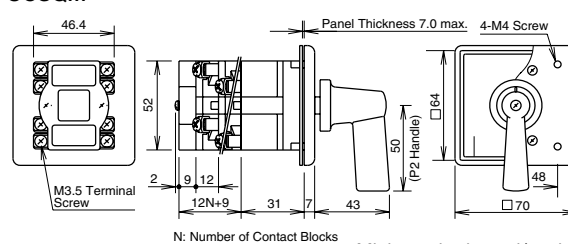

### Panel Cut-out

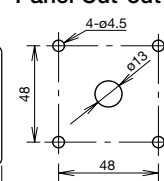

- Minimum horizontal/vertical mounting centers  
With P2 handle: 125  
With other handles: 70

All dimensions in mm.

# ø30/ø25 CS Series Cam Switches

## Ordering Information

When ordering, specify items ① through ⑦ as the designation example below.

① Model	② Contact Block Decks	③ Positions	④ Angle	⑤ Spring Return	⑥ Handle	⑦ Key irremovable position	⑧ Circuit No.
------------	--------------------------	----------------	------------	--------------------	-------------	-------------------------------	------------------

①	②		③		④		⑤		⑥	⑦	⑧
	Decks	Code	Positions	Code	Angle	Code	Return	Code			
ACSNO	1 deck	1	2 positions	2	30°	3	Spring return from left	RO	(Code) Y2, S2, P2, F2, H2, 25S2 (Color) B: Black See table below.  25S2 is for ACSSO only.  Standard ACSNK/ACSSK: no specification required	For ACSNK/ACSSK, specify the code(s) of irremovable position(s) in numerical order.	For standard contact configurations, use designation code on pages 55 to 57. For custom contact configurations, use the Custom Contact Configuration Specification Sheet on page 58.
ACSNK	2 decks	2	3 positions	3	45°	4	Spring return from right	OR			
ACSSO	3 decks	3	4 positions	4	60°	6	Spring return two-way	RR			
ACSSK	4 decks	4	5 positions	5	90°	9					
UCSQO	5 decks	5	6 positions	6							
UCSQM	6 decks	6	7 positions	7							
			8 positions	8							
			9 positions	9							
			10 positions	10							
			11 positions	11							
			12 positions	12							
	Spring return: 1 to 3 decks only		Spring return: 2 to 4 positions only		ACSNK/ACSSK: 45° and 90° only Spring return: 45° only		Spring return code is required only for spring return.				

### Designation Example



**UCSQO - 2 3 4 RR - S2B - C2006**

①      ②③④ ⑤      ⑥      ⑧  
**ACSNO - 2 3 4 RR - Y2B - MAU-C2006-ZT2**

- When a special contact configuration is required, specify the contact configuration using the Custom Contact Configuration Specification Sheet on page 58.
- A specified handle is attached.
- Accessories such as nameplates and jumpers are separately ordered.
- The key of the key operated cam switch is removable at every position unless otherwise specified. The key is irremovable at return position. The return and irremovable positions must be specified in Part No. Positions at 180° from irremovable positions are also irremovable.  
Example: 4-positions, spring return from right, irremovable at positions 3 and 4

**ACSNK-344OR-134-C3012**

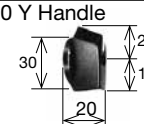
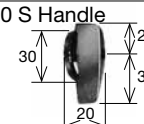
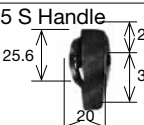
### Handle Designation Code

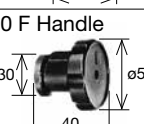
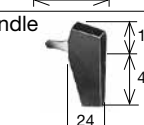
Shape	Code	Color	Applicable Cam Switch	
 ø25, ø30 Y Handle	Y2	B: black	ACSNO ACSSO UCSQO UCSQM	
 ø25, ø30 S Handle	S2			
 ø25, ø25 S Handle	25S2			ACSSO
 ø25, ø30 P Handle	P2			ACSNO ACSSO UCSQO UCSQM
 ø25, ø30 F Handle	F2			
 Key Handle	H2		ACSNK ACSSK	

### Spring Return Operation

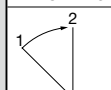
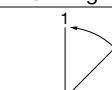
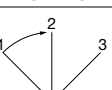
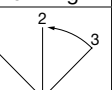
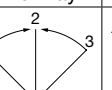
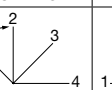
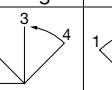
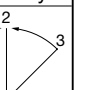

Available combinations of operator positions, angles, and return directions are listed in the table below.



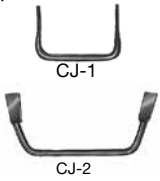

Positions	2-position		3-position		4-position		3-position	
	From Left	From Right	From Left	From Right	Two-way	From Left	From Right	Two-way
Return Direction								
③ ④ ⑤ Codes	24RO	24OR	34RO	34OR	34RR	44RO	44OR	34RR
Applicable Cam Switches	ACSNO, ACSSO, ACSNK, ACSSK, UCSQO							UCSQM
Contact Block Decks	1 to 3 decks							

Note: Maintained do not require spring return code ⑤.

# CS Series Accessories and Replacement Parts ø30/ø25

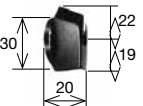
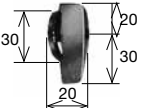
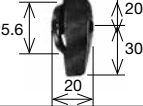
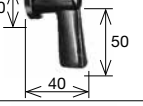
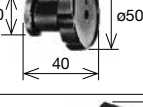
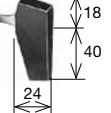
## Accessories and Replacement Parts

Shape	Material	Part No.	Ordering No.	Package Quantity	Remarks
Jumper  CJ-1 CJ-2	Metal (copper)	CJ-1	CJ-1PN10	10	For connecting terminals of adjoining contact blocks
		CJ-2	CJ-2PN10	10	For connecting terminals of the same contact block
Rubber Boot 	Nitril rubber	CR-1	CR-1	1	For preventing ingress of dust into the contact blocks Not applicable for the UCSQO and UCSQM
Terminal Cover  CS-VL2-13S      CS-VL2-46S Supplied with 2 self-tapping screws for mounting	Plastic (PPE)	CS-VL2-13S	CS-VL2-13S	1	For 1 to 3 decks of contact blocks
		CS-VL2-46S	CS-VL2-46S	1	For 4 to 6 decks of contact blocks

Shape	Material (Color)	Part No.	Ordering No.	Package Quantity
ø25, ø30 Y Handle 	Polybutylene terephthalate (Black)	CSH-YB	CSH-YB	1
ø25, ø30 S Handle 	Polybutylene terephthalate (Black)	CSH-SB	CSH-SB	1
ø25 S Handle 	Phenol resin (Black)	CSH-25SB	CSH-25SB	1
ø25, ø30 P Handle 	Phenol resin (Black)	CSH-PB	CSH-PB	1
ø25, ø30 F Handle 	Bakelite (Black)	CSH-FB	CSH-FB	1
Key Handle 	Phenol resin (Black)	CSH-H2B	CSH-H2B	1
Spare Keys 	Metal (brass nickel-plated)	CSH-K301	CSH-K301PN02	2
Handle Shaft 	Polyamide	CS-HF2C	CS-HF2CPN05	5
Handle Screw 	For Y, ø30 S, and ø25 S handles M3 × 12	CS-SCW-M3-12	CS-SCW-M3-12PN10	10
Handle Screw 	For P and F handles M3 × 25	CS-SCW-M3-25	CS-SCW-M3-25PN10	10

Instructions

Installing the Terminal Cover for the CS series Cam Switches

- Complete wiring before installing the terminal cover on the bottom plate of the contact block.
- The terminal cover has six holes. Of the four round holes at four corners, use two diagonal pair of holes to install the terminal cover. Either pair can be used.
- Insert the attached self-tapping screws into the pair of holes and tighten the screws to a torque of 0.8 to 1.0 N·m.
- For 1 through 3 decks of contact blocks, use terminal cover CS-VL2-13S.
- For 4 through 6 decks of contact blocks, use terminal cover CS-VL2-46S.
- The CS-VL2-46S consists of the CS-VL2-13S and a terminal cover for the fourth through sixth decks. Combine the two parts together as shown. Note that once combined, the two parts cannot be separated.

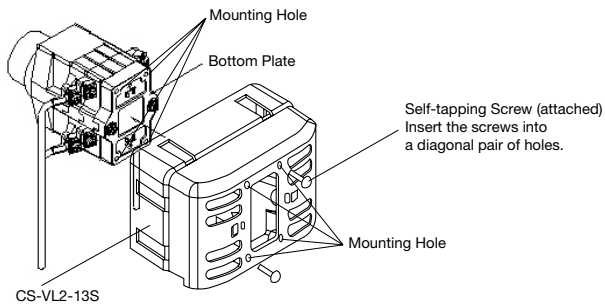

Minimum Mounting Centers for Installing the Terminal Cover

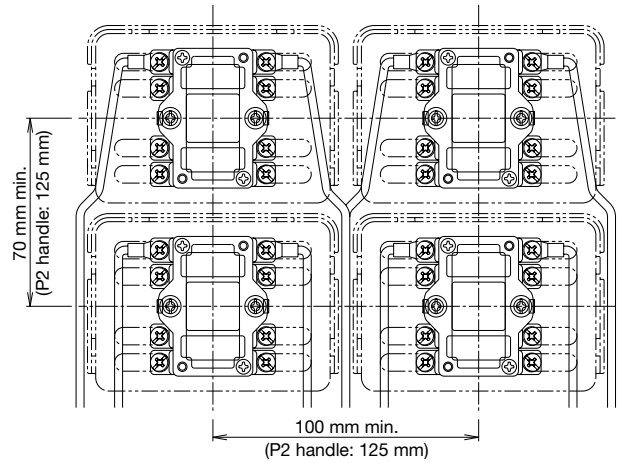

- Although the minimum mounting centers are 100 mm horizontally and 70 mm vertically, determine the mounting centers in consideration of convenience of wiring. For the P2 handle, the minimum mounting centers are 125 mm horizontally and vertically.

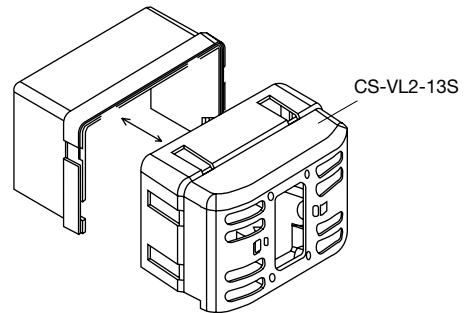

For 4 through 6 decks of contact blocks (CS-VL2-46S)

Terminal Cover Dimensions

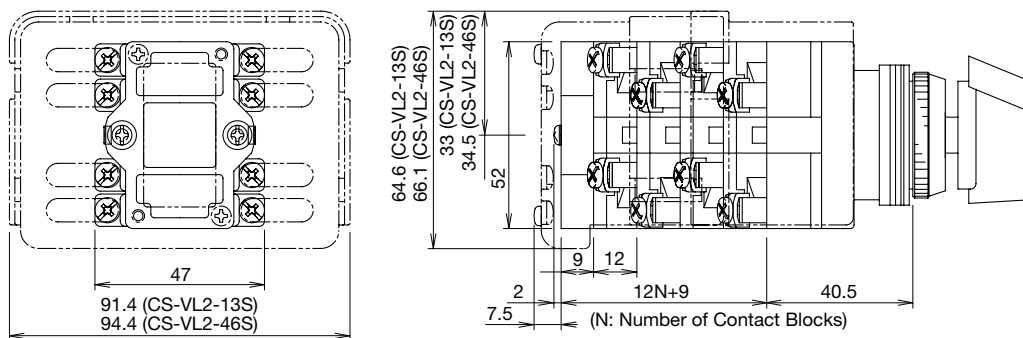

All dimensions in mm.

### Standard Contact Configurations

- The following table lists 76 standard contact configurations for easy designation of required cam switch operation.
- When other contact configurations are required, specify the number of contact block decks, operator positions, angles, and contact operation using the Custom Contact Configuration Specification Sheet on page 58.

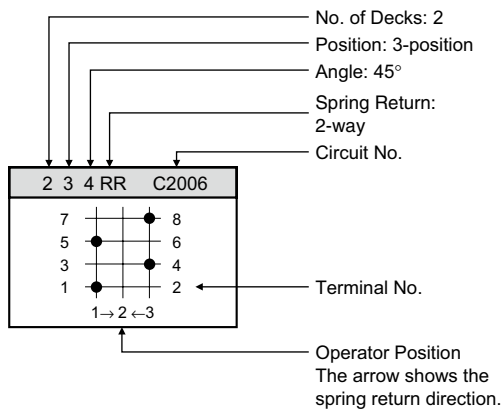

Symbol	Contact Operation
●	Contacts closed.
▬	Contacts remain closed between two operator positions.
▬ ▬	Overlapping Contacts Contacts of different decks are both closed at one point while the handle is turned to the next position.
○	Residual Contacts When the handle is returned to the center, the contacts remain closed. The contacts are opened when the handle is turned to the opposite direction.

### Listing Order of the Table

The 76 standard contact configurations are listed in the order of the circuit number.

### Same Circuits

Shown in the following examples, circuits of Fig. 1 and Fig. 2 have the same functions. When ordering, examine the standard contact configurations. Your requirements may be satisfied simply by changing external wiring of the standard contact configurations.

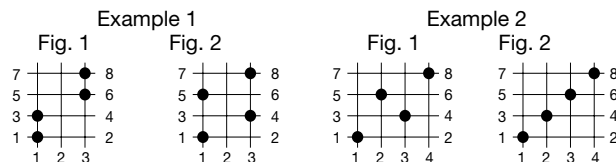

### Terminal Numbers

- The terminal numbers on the contact blocks correspond with the numbers shown in the chart as shown below.

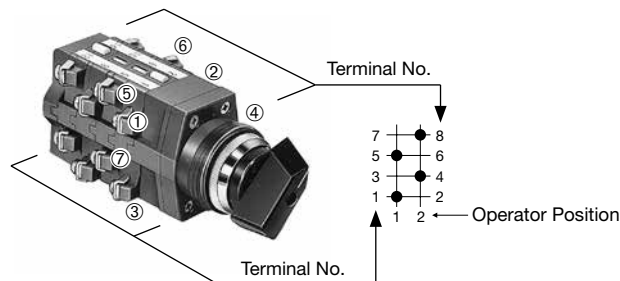

Standard Contact Configuration Chart

1 2 9 C1001	1 2 9 C1002	1 2 4 OR C1003	1 2 4 OR C1004	1 3 4 C1005
1 3 4 C1006	1 3 4 RR C1007	1 3 4 RR C1008	1 3 4 RR C1009	1 3 4 RR C1010
1 4 4 C1011	1 2 9 C1013	1 2 9 C1014	1 2 4 OR C1015	1 3 4 C1016
1 2 4 C1017	1 3 4 RR C1018	1 2 6 C1019		
2 2 9 C2001	2 2 9 C2002	2 3 4 C2003	2 3 4 C2004	2 3 4 C2005

# ø30/ø25 CS Series Instructions

<p>2 3 4 RR C2006</p>	<p>2 3 4 RR C2007</p>	<p>2 4 4 C2008</p>	<p>2 4 4 C2009</p>	<p>2 4 9 C2011</p>
<p>2 2 9 C2014</p>	<p>2 2 9 C2015</p>	<p>2 3 4 C2016</p>	<p>2 3 4 C2017</p>	
<p>2 3 4 C2019</p>	<p>2 3 4 C2020</p>	<p>2 3 4 RR C2021</p>	<p>2 4 4 C2022</p>	
		<p>2 5 3 C2027</p>	<p>2 3 6 C2028</p>	<p>2 3 6 C2029</p>
<p>3 2 9 C3001</p>	<p>3 3 4 C3002</p>	<p>3 5 4 C3003</p>	<p>3 6 4 C3004</p>	<p>3 3 4 C3005</p>
<p>3 4 9 C3008</p>	<p>3 4 9 C3009</p>	<p>3 2 9 C3010</p>	<p>3 3 4 C3011</p>	<p>3 4 4 C3012</p>
<p>3 6 3 C3013</p>	<p>3 3 6 C3014</p>	<p>3 6 6 C3015</p>	<p>3 5 3 C3016</p>	<p>3 4 4 C3017</p>
<p>3 3 6 C3018</p>		<p>4 4 4 C4001</p>	<p>4 8 4 C4002</p>	<p>4 4 9 C4003</p>
<p>4 2 4 C4004</p>	<p>4 2 9 C4005</p>	<p>4 2 9 C4006</p>	<p>4 4 9 C4007</p>	<p>4 3 4 C4008</p>



# CS Series Instructions ø30/ø25

4 5 4 <b>C4009</b>	5 3 4 <b>C5001</b>	6 4 4 <b>C6001</b>	6 12 3 <b>C6002</b>	
6 4 9 <b>C6003</b>	6 9 3 <b>C6004</b>	6 6 6 <b>C6005</b>	6 6 4 <b>C6006</b>	









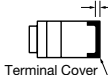

## Application Examples (Voltmeter and Ammeter Circuits)

1 2 6 C1019 (ammeter switching, 1CT circuit)	2 3 6 C2029 (ammeter switching, 2CT circuit)	2 4 9 C2011 (ammeter switching, 2CT circuit)
2 4 4 C2022 (voltmeter switching, 3PT circuit)	3 4 9 C3008 (voltmeter switching, 2PT circuit)	3 4 9 C3009 (voltmeter switching, 3PT circuit)
6 4 9 C6003 (ammeter switching, 3CT circuit)	4 4 9 C4003 (ammeter switching, 3CT circuit)	4 4 9 C4007 (ammeter switching, 2CT circuit)



## ø30 Series Accessories and Replacement Parts ø30

### Terminal Covers

Terminal Cover		N-VL2	N-VL3	N-VL4	APN-PVL	APD-PVL	Use of terminal covers increases the depth by the dimensions below. 
		 38.4H × 22W	 38H × 30.4W	 38.4H × 24W	 38H × 46W	 37H × 44W	
<b>ø30 Series Switches &amp; Pilot Lights</b>							
Pilot Light APN, APNE, UPQN, UPQNE	Full Voltage				X		+5.0 mm
Pilot Light APD, APDE						X	+5.2 mm
Pilot Light APN, APNE, APD, APDE, UPQN, UPQNE	Transformer DC-DC Converter		X				+2.7 mm
Pushbutton ABN, ABD, AON, AOD, AVN, ABGD, AJN, ABFD, ATN, AOFD, UBQN, AVD, UOQN, AJD, UWQN, AZD, ABBN, AYD, ABBS (ø25)  Selector Switch ASN, ASD, ASTN  Selector Pushbutton ABN, ASBD	1 contact block 	X					+0 mm
	2 contact blocks 	X 2 pieces					
	3 contact blocks 	X 2 pieces					
	4 contact blocks 	X 2 pieces					
Illuminated Pushbutton ALN, ALD, ALNE, ALDE, AOLN, AOLD, AOLNE, AOLDE, ALGN, ALGD, ALGNE, ALGDE, AOLGN, AOLGDE, ALFN, ALFD, ALFNE, ALFDE, AOLFN, AOLFD, AOLFNE, AOLFDE, AVLN, AVLD, AVLNE, AVLDE, AJLN, AJLD, AJLNE, AJLDE, ULQN, UOLQN  Illuminated Selector Switch ASLN, ASLD  Push-to-Check Pilot Light APN1**P	Full Voltage			X 2 pieces			+4.5 mm
	Transformer DC-DC Converter		X				+1.5 mm

#### Ordering Terminal Covers

- When ordering terminal covers, specify the Part No. and the quantity.

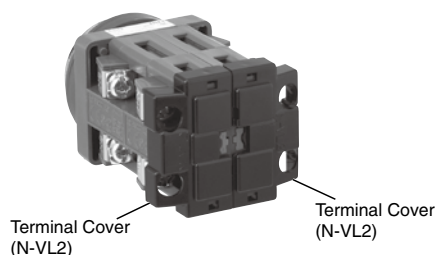

# ø30 ø30 series Accessories and Replacement Parts

## Nameplates

Model	Legend	Material	Part No.	Ordering No.	Package Quantity	Dimensions (mm)	Applicable Unit
NA	Blank	Aluminium 1.2 mm thick White letters on black background	NA-0	NA-0	1		ø30 switches & pilot lights
				NA-0PN10	10		
	With Legend		NA-*	NA-*	1		
				NA-*PN10	10		
NALO	Blank	Aluminium 1.2 mm thick Black	NALO	NALO	1		
				NALOPN10	10		
MLO	Blank	Brass (chrome-plated) 1.0 mm thick Matte	MLO	MLO	1		ARN/ARNS Mono-Lever
				MLOPN10	10		
CQ	Blank	Aluminium 0.5 mm thick White letters on black background	CQ-0	CQ-0	1	<ul style="list-style-type: none"> <li>• With adhesive tapes on the back</li> </ul>	UCSQO Cam Switch
				CQ-0PN10	10		
	With Legend (Legend Codes 31 and 53 only)		CQ-*	CQ-*	1		
				CQ-*PN10	10		
CQM	Blank	Aluminium 0.5 mm thick White letters on black background	CQM-0	CQM-0	1	<ul style="list-style-type: none"> <li>• With adhesive tapes on the back</li> </ul>	UCSQM Cam Switch
				CQM-0PN10	10		
	With Legend (Legend Code 31 only)		CQM-*	CQM-*	1		
				CQM-*PN10	10		

• Specify a legend code in place of \* in the Ordering No.

## ø30 Series Accessories and Replacement Parts ø30

### Nameplates

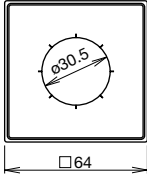
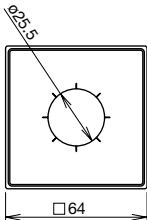
Model	Legend	Material	Part No.	Ordering No.	Package Quantity	Dimensions (mm)	Applicable Unit
CQN	Blank	Aluminium 0.5 mm thick  White letters on black background	CQN-0	CQN-0	1	<ul style="list-style-type: none"> <li>With adhesive tapes on the back</li> </ul> 	ACSNO, ACSNK Cam Switches ø30 mm Selector Switches
				CQN-0PN10	10		
	With Legend (Legend Codes 31, 35, and 53 only)		CQN-*	CQN-*	1		
				CQN-*PN10	10		
CQS	Blank	Aluminium 0.5 mm thick  White letters on black background	CQS-0	CQS-0	1	<ul style="list-style-type: none"> <li>With adhesive tapes on the back</li> </ul> 	ACSSO, ACSSK Cam Switches ø25 mm Selector Switches
				CQS-0PN10	10		
	With Legend (Legend Code 53 only)		CQS-*	CQS-*	1		
				CQS-*PN10	10		

• Specify a legend code in place of \* in the Ordering No.

### Legends

Code	Legend
0	(blank)
1	ON
2	OFF
3	START
4	STOP
31	OFF-ON
35	HAND-AUTO
53	HAND-OFF-AUTO

### Shape and Engraving Area

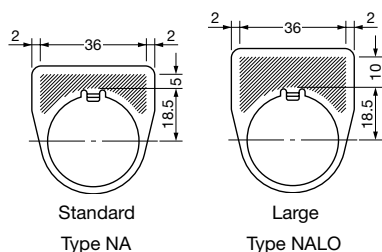











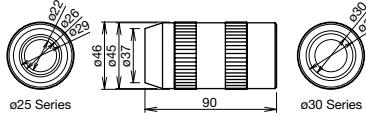

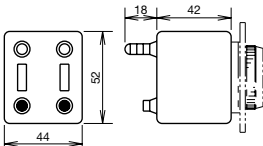

### Example

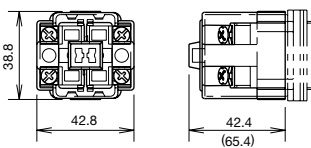
Shape	Engraving Area		Max. No. of Lines	No. of Letters on 1 Line
	Height	Width		
Standard	5	36	1	14
Large	10	36	2	14

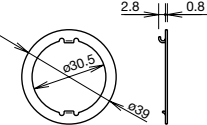
The above example is when the letter is 4 mm tall.

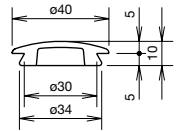

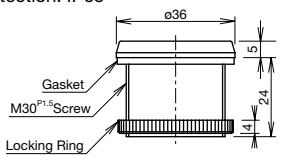

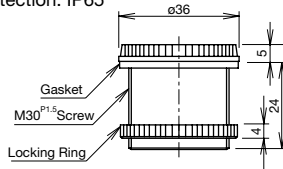



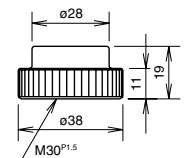

# ø30 ø30 series Accessories and Replacement Parts

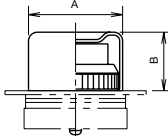
## Accessories

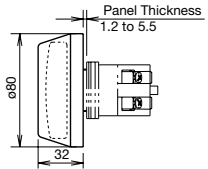
Shape	Material	Part No.	Ordering No.	Package Quantity	Dimensions (mm)
Locking Ring Wrench 	Nitril rubber	OR-12	OR-12	1	<ul style="list-style-type: none"> <li>Used to tighten the locking ring when installing the ø30 or ø25 switch onto a panel.</li> </ul> 
Lamp Holder Tool 	Nitril rubber	OR-55	OR-55	1	<ul style="list-style-type: none"> <li>Used to install and remove the LED lamps. See page 67.</li> </ul> 
Contact Rubber Boot For momentary 1 layer of contact blocks (2 contact blocks) 	Nitril rubber (black)	OC-99	OC-99	1	<ul style="list-style-type: none"> <li>Rubber boot used to prevent oil and dirt from entering into the contact block.</li> <li>Temperature range: -5 to +60°C</li> <li>Cannot be used for zinc diecast switches &amp; pilot lights.</li> </ul> 
Contact Rubber Boot For 1 layer of contact blocks (2 contact blocks) 	Silicone rubber (translucent)	OC-90	OC-90	1	<ul style="list-style-type: none"> <li>Applicable to AVN3 and AJN3.</li> <li>Applicable to ø30 diecast zinc pushbuttons and selector switches.</li> </ul> 
Contact Rubber Boot For 2 layers of contact blocks (4 contact blocks) 		OC-290	OC-290	1	
Anti-rotation Ring 	Metal (diecast) (zinc-plated)	OGL-11	OGL-11PN10	10	<ul style="list-style-type: none"> <li>Used to prevent the operator from turning. Generally used when using no nameplates on selector switches and selector pushbuttons.</li> </ul> 
Rubber Mounting Hole Plug 	Nitril rubber (black)	OB-13B	OB-13BPN05	5	<ul style="list-style-type: none"> <li>Used to plug unused ø30mm mounting holes.</li> <li>Gray also available. Ordering No.: OB-13PN05</li> </ul> 
Plastic Mounting Hole Plug 	Plastic (gray) Plug: ABS Gasket: Chloroprene rubber	OBP-11	OBP-11	1	<ul style="list-style-type: none"> <li>Tightening torque: 1.2 N·m.</li> <li>Degree of protection: IP65</li> </ul> 
Metallic Mounting Hole Plug 	Metal (diecast) (zinc-plated)	OB-11	OB-11	1	<ul style="list-style-type: none"> <li>Tightening torque: 1.2 N·m.</li> <li>Degree of protection: IP65</li> </ul> 

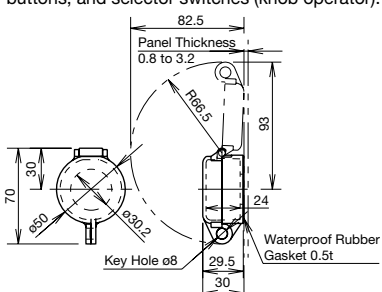

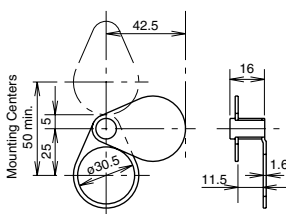

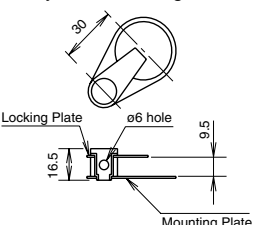



# ø30 Series Accessories and Replacement Parts ø30

## Accessories

Shape		Material	Part No.		Ordering No.	Package Quantity	Dimensions (mm)							
		Nitril rubber	Color	Part No.	-	-	<ul style="list-style-type: none"> <li>• Metallic bezels covered with a rubber boot to enhance waterproof characteristics.</li> <li>• Button is not included. Applicable to extended pushbuttons only.</li> </ul> 							
			Black	OC-11B	OC-11B	1								
			Green	OC-11R	OC-11R	1								
			Red	OC-11G	OC-11G	1								
			Yellow	OC-11Y	OC-11Y	1								
	For flush pushbuttons	EPDM rubber	OC-121		OC-121	1	<ul style="list-style-type: none"> <li>• Used to cover and protect pushbuttons where units are subject to water splash. Not suitable for outdoor use or where the units are subject to oil splash.</li> </ul> 							
For extended pushbuttons	OC-122		OC-122	1	<table border="1" style="margin: auto;"> <thead> <tr> <th></th> <th>A</th> <th>B</th> </tr> </thead> <tbody> <tr> <td>OC-121</td> <td style="text-align: center;">37</td> <td style="text-align: center;">16</td> </tr> <tr> <td>OC-122</td> <td style="text-align: center;">37</td> <td style="text-align: center;">16</td> </tr> </tbody> </table>			A	B	OC-121	37	16	OC-122	37
	A	B												
OC-121	37	16												
OC-122	37	16												
		Nitril rubber (black)	OC-4GN	OC-4GN	1	<ul style="list-style-type: none"> <li>• Used for ABN4G pushbuttons.</li> </ul> 								
		Polyarylate (gasket: nitril rubber)	OL-KL1	OL-KL1	1	<ul style="list-style-type: none"> <li>• Used to protect pushbuttons, illuminated pushbuttons, and selector switches (knob operator).</li> </ul> 								
		Metal (zinc-plated brass)	OL-C	OL-C	1	<ul style="list-style-type: none"> <li>• Used to protect flush pushbuttons from inadvertent operation.</li> <li>• Can be easily attached using the locking ring.</li> </ul> 								
		Metal (zinc-plated brass)	OL-H	OL-H	1	<ul style="list-style-type: none"> <li>• Used to lock an extended pushbutton in the depressed position.</li> <li>• Can be easily attached using the locking ring.</li> </ul> 								

## ø30 ø30 series Accessories and Replacement Parts

### Maintenance Parts

Shape	Specification	Part No.	Ordering No.	Package Quantity	Remarks
Metallic Bezel 	Metal (zinc diecast: chrome-plated)	OG-11	OG-11PN02	2	<ul style="list-style-type: none"> <li>Cannot be used with pin lock, selector pushbuttons, and mono-lever units.</li> </ul>
Plastic Bezel 	Polycarbonate	OGP-11*	OGP-11*PN02	2	Specify a color code in place of *. B (black), G (green), R (red), W (white), Y (yellow) <ul style="list-style-type: none"> <li>Cannot be used with pin lock, selector pushbuttons, and mono-lever units.</li> </ul>
Clear Plastic Bezel for Flush Pushbuttons 	Acrylic (clear)	OGP-13	OGP-13PN02	2	<ul style="list-style-type: none"> <li>Clear plastic bezel and full shroud.</li> <li>OGP-1411 cannot be used with LED illumination units and diecast units.</li> </ul>
Clear Plastic Bezel for Extended Pushbuttons 		OGP-14	OGP-14PN02	2	
Clear Plastic Bezel for Illuminated Pushbuttons 		OGP-1411	OGP-1411	1	
Metal Bezel for Illuminated Pushbuttons 	Metal (zinc diecast)	OL-11	OL-11PN05	5	
Clear Button Cover 	Polycarbonate (clear)	ABN1B-C	ABN1B-CPN05	5	<ul style="list-style-type: none"> <li>Used on flush and extended pushbuttons to indicate a mark or a symbol engraved on the marking plate. The clear button cover holds the marking plate. The ø30 series marking chip can only be used on the ABN1 and AON1.</li> <li>Specify a color code in place of *.                B (black), G (green), R (red), W (white), Y (yellow)</li> </ul>
Marking Plate 	Polyacetal	TN-0*	TN-0*PN10	10	



# ø30 Series Accessories and Replacement Parts ø30









## Maintenance Parts

Shape	Description	Material	Part No.	Ordering No.	Package Quantity	Color	
	NO contact		BS010E	BS010E	1	<ul style="list-style-type: none"> <li>• Push rod color: Green</li> <li>• -MAU has gold contacts</li> </ul>	
			BS010E-MAU	BS010E-MAU			
	NC contact			BS001E	BS001E	1	<ul style="list-style-type: none"> <li>• Push rod color: Red</li> <li>• -MAU has gold contacts</li> </ul>
				BS001E-MAU	BS001E-MAU		
	EM contact (early make)			BS010SE	BS010SE	1	<ul style="list-style-type: none"> <li>• Push rod color: Black</li> <li>• -MAU has gold contacts</li> </ul>
				BS010SE-MAU	BS010SE-MAU		
	LB contact (late break)			BS001SE	BS001SE	1	<ul style="list-style-type: none"> <li>• Push rod color: White</li> <li>• -MAU has gold contacts</li> </ul>
				BS001SE-MAU	BS001SE-MAU		
	NO contact		BST010	BST010	1	<ul style="list-style-type: none"> <li>• Push rod color: Green</li> <li>• -MAU has gold contacts</li> </ul>	
			BST010-MAU	BST010-MAU			
	NC contact			BST001	BST001	1	<ul style="list-style-type: none"> <li>• Push rod color: Red</li> </ul>
				BST001-MAU	BST001-MAU		
	EM contact (early make)			BST010S	BST010S	1	<ul style="list-style-type: none"> <li>• Push rod color: Black</li> </ul>
	LB contact (late break)			BST001S	BST001S	1	<ul style="list-style-type: none"> <li>• Push rod color: White</li> </ul>
		① Used for APN(E)1	AS resin	APN106LN-②	APN106LN-②PN05	5	<ul style="list-style-type: none"> <li>A (amber), C (clear), G (green), R (red), S (blue), W (white), Y (yellow)</li> <li>• Use the white (W) lens for pure white (PW) illumination</li> </ul>
		② Used for UPQNE4 U(O)LQN*B		UPQN406L-②	UPQN406L-②PN05	5	<ul style="list-style-type: none"> <li>C (clear), G (green), R (red), S (blue)</li> <li>• Use the clear (C) lens for white illumination.</li> </ul>
		UPQN406LD-②		UPQN406LD-②PN05	<ul style="list-style-type: none"> <li>A (amber), Y (yellow)</li> <li>• Use the amber (A) lens for orange illumination.</li> </ul>		
③ Used for UPQN3B U(O)LQN		ULQN06L-②		ULQN06L-②PN05	5	<ul style="list-style-type: none"> <li>C (clear), G (green), R (red), S (blue)</li> </ul>	
		UPQN06LD-②		UPQN06LD-②PN05		<ul style="list-style-type: none"> <li>A (amber), W (white), Y (yellow)</li> <li>• Use the amber (A) lens for orange illumination.</li> </ul>	
	① Used for ALN, AOLN (LED)	AS resin	ALN2L-②	ALN2L-②PN05	5	<ul style="list-style-type: none"> <li>C (clear), G (green), R (red), S (blue)</li> </ul>	
			ALN2LD-②	ALN2LD-②PN05	5	<ul style="list-style-type: none"> <li>A (amber), W (white), Y (yellow)</li> <li>• Use the white (W) lens for pure white (PW) illumination</li> </ul>	
	Flush	Polyacetal	ABN1B-①	ABN1B-①PN05	5	<ul style="list-style-type: none"> <li>G (green), R (red), Y (yellow)</li> <li>Above colors are used for ø30 switches &amp; pilot lights (dark colored operator units).</li> <li>For black, use black buttons from light colored operator units.</li> </ul>	
	Extended		ABN2B-①	ABN2B-①PN05	5		
	Mushroom		ABN3B-①	ABN3B-①PN02	2		
	Flush	Polyacetal	ABN1BN-①	ABN1BN-①PN05	5	<ul style="list-style-type: none"> <li>B (black), G (green), R (red), S (blue), Y (yellow), W (white)</li> <li>Above colors are used for ø30 diecast zinc switches &amp; pilot lights (light colored operator units).</li> </ul>	
	Extended		ABN2BN-①	ABN2BN-①PN05	5		
	Mushroom		ABN3BN-①	ABN3BN-①PN02	2		
	① Mushroom (ABN4)	Urea-formaldehyde resin	ABN4B-①	ABN4B-①	1	<ul style="list-style-type: none"> <li>B (black), G (green), R (red), Y (yellow)</li> </ul>	
	② Mushroom (ABN4G/ABN4F)		ABN4GB-①	ABN4GB-①	1		
	③ Square Flush (UBQN1)	Polyacetal	UBQN1B-①	UBQN1B-①PN02	2		
	④ Square Extended (UBQN2)		UBQN2B-①	UBQN2B-①PN02	2		

Note: Specify a button color code or Lens/LED Color Code in place of ① or ② in the Ordering No.



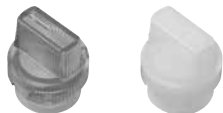

# ø30 ø30 series Accessories and Replacement Parts

## Maintenance Parts

Shape	Description	Material	Part No.	Ordering No.	Package Quantity	Remarks
Button 	For ø40 pushlock turn reset pushbuttons (for AVN3)	AS resin	AVN3B-②	AVN3B-②	1	R (red), Y (yellow)
Lens 	For ø40 pushlock turn reset pushbuttons (for AVLN3, AVLNE3)	AS resin	AVLN3L-R	AVLN3L-RPN02	2	Red only
Lens 	For ø40 pushlock turn reset pushbuttons (for AJN3)	AS resin	AJN3B-②	AJN3B-②	1	B (black), G (green), R (red), Y (yellow)
Lens 	For ø40 pushlock turn reset pushbuttons (for AJLN3)	AS resin	AJLN3L-②	AJLN3L-②	1	-G (green), -R (red), L-Y (yellow), L-A (amber), L-W (white)
Marking Plate 	For UPQN4	Acrylic	UPQN406N-W	UPQN406N-WPN05	5	
Rubber Washer (3.0mm thick) 		Synthetic soft vinyl	OW-12	OW-12PN10	10	
Rubber Washer (1.5mm thick) 			OW-11	OW-11PN10	10	
Shroud 	① Half shroud (for pushbuttons)	Metal (zinc diecast)	ABN2G	ABN2G	1	
	② Full shroud (for pushbuttons)		ABN2F	ABN2F	1	
	③ Full shroud (for mushroom pushbuttons)		ABN3G	ABN3G	1	
	④ Shallow shroud (for jumbo mushrooms)		ABN4G	ABN4G	1	
	⑤ Deep shroud (for jumbo mushrooms)		ABN4F	ABN4F	1	
	⑥ Half shroud (for illuminated pushbuttons)		ALN2GL	ALN2GL	1	• For LED illuminated pushbuttons (BA9S base)
	⑦ Full shroud (for illuminated pushbuttons)		ALN2FL	ALN2FL	1	• For LED illuminated pushbuttons (BA9S base)
Selector Knob 	Knob for illuminated selector switch	AS resin	ASLNH	ASLNH-*	1	G (green), R (red), S (blue)
			ASLNHD	ASLNHD-*		A (amber), W (white), Y (yellow)

## ø30 Series Accessories and Replacement Parts ø30

### Maintenance Parts

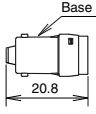

Shape	Description	Material	Part No.	Ordering No.	Package Quantity	Remarks
Spare Key 	① ASN3K/4K, ABN5	Metal (nickel plated brass)	ASN-T1SK-24401	ASN-T1SK-24401PN02	2	• Applicable to ABN3K, ABN4K, ABN5
	② ASN*K		ASN-SK-24401	ASN-SK-24401PN02		
Spare Key 	ASN□K□-T ASN*K		TW-SK-0	TW-SK-0PN02	2	
Transformer 	100/110V AC (for LED lamps)		TWR-016N	TWR-016N	1	Mounting screws are not included.
	200/220V AC (for LED lamps)		TWR-026N	TWR-026N	1	
Pin/Chain 	For ABN8P pinlock	Metal	ABN8P-PIN	ABN8P-PIN	1	Pin, chain, and plate for ABN8P

### LED Lamps

Dimensions	Operating Voltage	Current Draw		Part No.	Ordering No.	② Illumination Color Code	Package Quantity	Base
		AC	DC					
 Base BA9S/13 	6V AC/DC ±10%	8 mA	7 mA (A, R, W) 5.5 mA (G, PW, S)	LSTD-6②	LSTD-6②	A: amber G: green PW: pure white R: red S: blue W: white	1	BA9S/13
				LSTD-6②PN10	LSTD-6②PN10		10	
	12V AC/DC ±10%	11 mA	10 mA	LSTD-1②	LSTD-1②	Use a pure white (PW) LED lamp for yellow (Y) illumination.	1	
				LSTD-1②PN10	LSTD-1②PN10		10	
	24V AC/DC ±10%	11 mA	10 mA	LSTD-2②	LSTD-2②		1	
				LSTD-2②PN10	LSTD-2②PN10		10	

# ø30 ø30 series Accessories and Replacement Parts

## Transformer

DIN Rail Mount	Primary Voltage	Secondary Voltage	Part No.	Applicable Load
	100/110V AC	5.5V	TWR516	One full voltage pilot light or illuminated switch containing LSTD-6②
	200/220V AC		TWR526	
	400/440V AC		TWR546	
 	100/110V AC	23V	TWR512	One full voltage pilot light or illuminated switch containing LSTD-2②
	200/220V AC		TWR522	
	400/440V AC		TWR542	

## Specifications

Part No.	TWR5□6	TWR5□2
Operating Voltage	100/110V AC, 200/220V AC, 400/440V AC (50/60Hz)	
Current Draw	2.4 VA	
Rated Insulation Voltage	600V	
Insulation Resistance	100 MΩ minimum (500V DC megger)	
Operating Temperature	-30 to +60°C (no freezing)	
Storage Temperature	-40 to +80°C (no freezing)	
Operating Humidity	35 to 85% RH (no condensation)	
Vibration Resistance	Damage Limits: 30 Hz, amplitude 1.5 mm Operating extremes: 5 to 55 Hz, amplitude 0.5 mm	
Shock Resistance	Damage limits, Operating Extremes: 1,000 m/s <sup>2</sup>	
Dielectric Strength	2,500V AC, 1 minute	
Terminal Screw	M3.5	
Applicable Wire	2 mm <sup>2</sup> maximum, 2 wires maximum	
Weight (approx.)	87g	

## Dimensions

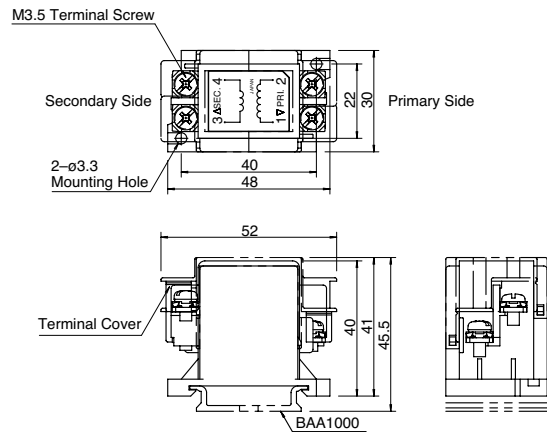

## Accessories

### DIN Rail

Part No.	Ordering No.	Length	Weight (approx.)	Material	Package Quantity
BAA1000	BAA1000PN10	1000 mm	200g	Aluminum	10
BAP1000	BAP1000PN10	1000 mm	320g	Steel	10

### End Clip

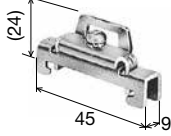
Part No.	Ordering No.	Applicable DIN Rail	Weight (approx.)	Material	Package Quantity	Dimensions
BNL6	BNL6PN10	BAA1000 BAP1000	15g	Steel (Zinc-plated)	10	 (24) 45 9

## Safety Precautions

- Turn off the power to the ø30 series switches & pilot lights before starting installation, removal, wiring, maintenance, and inspection of the products. Failure to turn power off may cause electrical shocks or fire hazard.
- To avoid a burn on your hand, use the lamp holder tool when replacing lamps.
- For wiring, use wires of a proper size to meet the voltage and current requirements. Tighten the M3.5 terminal screws to a tightening torque of 1.0 to 1.3 N·m. Failure to tighten terminal screws may cause overheat and fire.

## Instructions

### Panel Mounting for Square Pushbuttons and Pilot Lights

1. Tighten the square ring to the operator and position the ring correctly.
2. Lightly tighten the screw to secure the pilot light onto the panel.

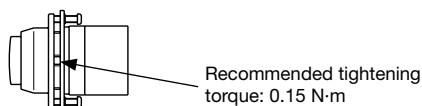

### Tightening Torque for Terminal Screws

Tighten the terminal screws to a torque of 1.0 to 1.3 N·m.

### Replacement of Lamps

Lamps can be replaced by using the lamp holder tool (OR-55) from the front of the panel.

#### How to Remove

To remove, slip the lamp holder tool onto the lamp head lightly. Then push slightly, and turn the lamp holder tool counterclockwise.

#### How to Install

To install, insert the lamp head into the lamp holder tool. Place the pins on the lamp base to the grooves in the lamp socket. Inset the lamp and turn it clockwise.



OR-55



### Installing the Anti-rotation Ring

Anti-rotation rings are used on selector switches or pushbuttons which rotate and used when using no nameplates.

Insert a 1.5mm thick rubber washer between the panel and the anti-rotation ring as shown on the right.

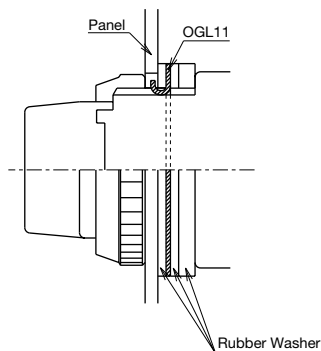

### Panel Thickness and Rubber Washer

Adjust the thickness of the rubber washers according to the panel thickness. Also, make sure to include the nameplate thickness when using a nameplate.

#### Applicable Models

- Extended Illuminated Pushbuttons with Half Shroud (LED)
- Extended Pushbuttons with Half Shroud (Diecast)
- Extended Illuminated Pushbuttons with Half Shroud (Diecast)

Panel Thickness (mm)	Rubber Washer	
	1.5mm	3.0mm
Supplied	1 piece	1 piece
0.8 to 1.8	–	1 piece
1.8 to 3.5	1 piece	–

#### Applicable Models

- Extended Illuminated Pushbuttons with Full Shroud (LED)
- Extended Illuminated Pushbuttons with Full Shroud (Diecast)
- Mushroom Pushbuttons with Full Shroud

Panel Thickness (mm)	Rubber Washer	
	1.5mm	3.0mm
Supplied	2 pieces	1 piece
0.8 to 2.0	1 piece	1 piece
2.0 to 3.5	1 piece	1 piece
3.5 to 5.0	–	1 piece
5.0 to 6.0 (6.5)	1 piece	–

The number in brackets is for mushroom pushbuttons with full shroud.

#### Applicable Models

- Toggle Lever
- Knob Push Turn Lock Illuminated Pushbuttons

Panel Thickness (mm)	Rubber Washer	
	1.5mm	3.0mm
Supplied	1 piece	1 piece
0.8 to 2.0	1 piece	1 piece
2.0 to 3.5	–	1 piece
3.5 to 5.5 (5.0)	1 piece	–

The number in brackets is for knob push turn lock illuminated pushbuttons.

#### Applicable Models

- Extended Pushbuttons with Half Shroud

Panel Thickness (mm)	Rubber Washer	
	1.5mm	3.0mm
Supplied	1 piece	1 piece
0.8	1 piece	1 piece
0.8 to 2.3	–	1 piece
2.3 to 4.0	1 piece	–

#### Applicable Models

- Extended Pushbuttons with Full Shroud

Panel Thickness (mm)	Rubber Washer	
	1.5mm	3.0mm
Supplied	3 pieces	1 piece
0.8 to 1.5	3 pieces	1 piece
1.5 to 3.0	2 pieces	1 piece
3.0 to 4.5	1 piece	1 piece
4.5 to 6.0	–	1 piece
6.0 to 7.5	1 piece	–

#### Applicable Models

- Extended Pushbuttons with Full Shroud (Diecast)

Panel Thickness (mm)	Rubber Washer	
	1.5mm	3.0mm
Supplied	2 pieces	1 piece
0.8 to 2.5	2 pieces	1 piece
2.5 to 4.0	1 pieces	1 piece
4.0 to 5.5	–	1 piece
5.5 to 6.0	1 piece	–

#### Applicable Models

- Other Models (Excluding Square)

Panel Thickness (mm)	Rubber Washer	
	1.5mm	3.0mm
Supplied	2 pieces	1 piece
0.8 to 3.5	2 pieces	1 piece
3.5 to 5.0	1 piece	1 piece
5.0 to 6.5	–	1 piece
6.5 to 7.5	1 piece	–

## Installation of LED Illuminated Units

1. Note the polarity for wiring when connecting to DC-DC converter unit.

Terminal No.	Polarity
X1	Positive
X2	Negative

2. Transformer units are recommended for use in areas subjected to noise.

3. Notes for Pure White LED Lamps

- Do not use the pure white LED outdoors, otherwise it will lead to the degradation of brightness and color. Do not remove or apply shock to the cap on the pure white LED lamp, otherwise it may break or damage the cap.
- For the pure white LED, use a white lens. The illumination color will be dull if a different color is used.

## Notes on LED Illuminated Units

LED lamps consist of semiconductors. If the applied voltage exceeds the rated voltage, LED elements may deteriorate due to overheat, resulting in significant decrease in luminance, hue change, or failure of lighting. Also, if an extraneous noise, transient voltage, or transient current is applied to the circuit, similar effects may occur. When using LED lamps, observe the following instructions.

### Rated Voltage

The LED lamps are rated at 6V, 12V, or 24V AC/DC, and can be used within  $\pm 10\%$  the rated voltage of either AC or DC.

### DC Power

1. Switching power supply

Regulated voltage from switching power supply is best suited. Make sure to use within the rated voltage of the LED lamp.

2. Rechargeable battery

Note that the battery voltage may exceed the rated voltage of the LED lamp while the battery is being charged and immediately after the charging is complete. Be sure to use the LED lamp on a voltage of  $\pm 10\%$  the rated voltage.

3. Full-wave rectification

Since the LED lamp is AC/DC compatible, a diode bridge for rectification is not necessary. If the LED lamp is used on a full-wave rectification current through a diode bridge, the rectifier diodes will reduce the voltage, resulting in lower luminance.

4. Single-phase half-wave rectification

This is not suitable for the power source of LED lamps. Use constant-voltage DC power.

### Noise

LED elements deteriorate due to extraneous noise, resulting in significant decrease in luminance, hue change, or failure of lighting. When such effects are anticipated, take a protection measure shown below, such as RC elements or a surge absorber.

### [Protection Example 1] For AC circuit

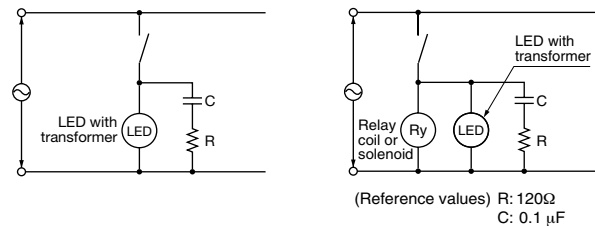

### [Protection Example 2] For DC circuit

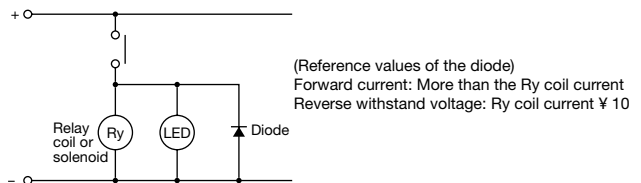

### Countermeasures against Dim Lighting

1. Leakage currents through the transistors or a contact protection circuit may cause the LED lamp to illuminate dimly even when the output is off.
2. When the LED lamp is illuminated by a transistor output, take the following measure.

### [Circuit Example]

Connect shunt resistor R in parallel with the LED lamp.

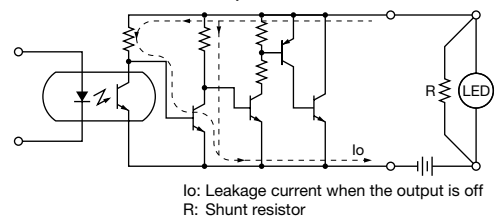

# ø30 Series Diecast Zinc Switches & Pilot Lights

## Heavy duty switches for tough industrial usage

- Degree of protection: IP65 (IEC 60529)
- UL, CSA approved, and EN compliant

Applicable Standards	Mark	File No. or Organization
UL 508		UL Listing File No. E68961
CSA C22.2 No.14		CSA File No. LR21451
EN60947-5-1		EU Low Voltage Directive
GB14048.5		CCC No. 200501030514650



## Specifications and Ratings

### Contact Ratings

	Contact Block	BST (ø30 series)
Pushbuttons Illuminated Pushbuttons Selector Switches Illuminated Selector Switches Selector Pushbuttons	Rated Insulation Voltage	600V
	Rated Continuous Current	10A
	Contact Ratings by Utilization Category IEC 60947-5-1	AC-15 (A600) DC-13 (P600)

### Weight (Examples)

Weight (approx.)	
	135g (ABD 122N)
	71g (APD122DN)
	116g (ALD22211DN)
	125g (ASD222N)
	168g (ASD2K22N)
	147g (ASLD2222DN)
	116g (ASBD211N-A03)

## Characteristics

### Contact Ratings by Utilization Category

Operational Voltage			24V	48V	50V	110V	220V	440V
Operational Current	AC 50/60 Hz	AC-12 Control of resistive loads and solid state loads	10A	—	10A	10A	6A	2A
		AC-15 Control of electromagnetic loads (> 72 VA)	10A	—	7A	5A	3A	1A
	DC	DC-12 Control of resistive loads and solid state loads	10A	5A	—	2.2A	1.1A	—
		DC-13 Control of electromagnets	5A	2A	—	1.1A	0.6A	—

Note: The operational current represents the classification by making and breaking currents (IEC 60947-5-1).  
Minimum applicable load: 3V AC/DC, 5 mA (applicable range may vary with operating conditions and load types)

## BST Contact Block (Light Gray)

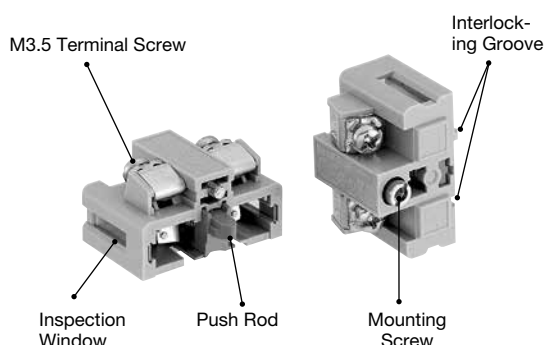

### Contact Blocks

		Single-pole Contact Block			
Contact		1NO	1NC	1EM (early make)	1LB (late break)
Part No.	BST	BST010	BST001	BST010S	BST001S
Push Rod		Green	Red	Black	White

Note: BST contact blocks are not interchangeable with dark gray BS contact blocks used for ø30 switches & pilot lights.

Specifications, ratings, and mounting hole layouts are the same as ø30 switches & pilot lights.  
See "ø30 Series Switches & Pilot Lights" on page 16.

# ø30 ø30 Series Diecast Zinc Switches & Pilot Lights

## Ordering Information

### Standard Units

- Specify an operator or Lens/LED Color Code in the Part No.
- Black, green, and red colored buttons are included with flush pushbuttons.
- Terminal covers, nameplates, and accessories are ordered separately.

### Terminal Cover

- When a terminal cover is required, order an applicable terminal cover referring to page 59.

The Part No. development charts shown below can be used to specify switches & pilot lights other than those listed on the following pages.

### ø30 Series Diecast Zinc Pushbuttons

ABD2 11 N R

Button color code

Contact Configuration

10: 1NO	01: 1NC
11: 1NO-1NC	20: 2NO
02: 2NO	22: 2NO-2NC
40: 4NO	04: 4NO
13: 1NO-3NC	31: 3NO-1NC
30: 3NO	03: 3NC
12: 1NO-2NC	21: 2NO-1NC

Note:

- Mushroom pull AZD3 can have a maximum of two contact blocks.
- Mushroom push pull AYD31 can have a maximum of two contact blocks.

### ø30 Series Diecast Zinc Illuminated Pushbuttons

ALDE 2 16 11 D N R

Lens/LED Color Code

Contact configuration

11: 1NO-1NC	20: 2NO
02: 2NC	31: 3NO-1NC
22: 2NO-2NC	13: 1NO-3NC
40: 4NO	04: 4NC

Operating voltage code

Lamp receptacle

(blank): BA9S (LSTD-6② LED)

Note:

- Illuminated pushbuttons cannot have an odd number of contact blocks, such as 1NO, 1NC, 3NO, 2NO-1NC, 1NO-2NC, and 3NC.

### ø30 Series Diecast Zinc Pilot Lights

APDE 1 99 D N R

Lens/LED Color Code

Operating voltage code

Lamp receptacle:

(blank): BA9S (LSTD-6② LED)



# ø30 Series Diecast Zinc Switches & Pilot Lights ø30

## ø30 Series Diecast Zinc Selector Switch

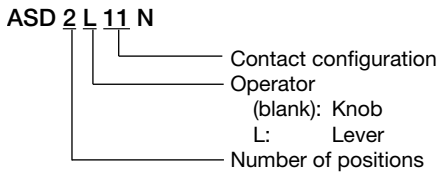

## ø30 Series Diecast Zinc Illuminated Selector Switch

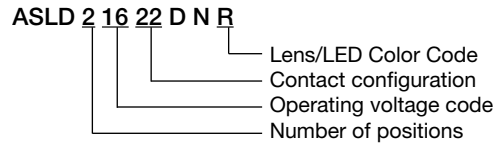

## ø30 Series Diecast Zinc Key Selector Switch

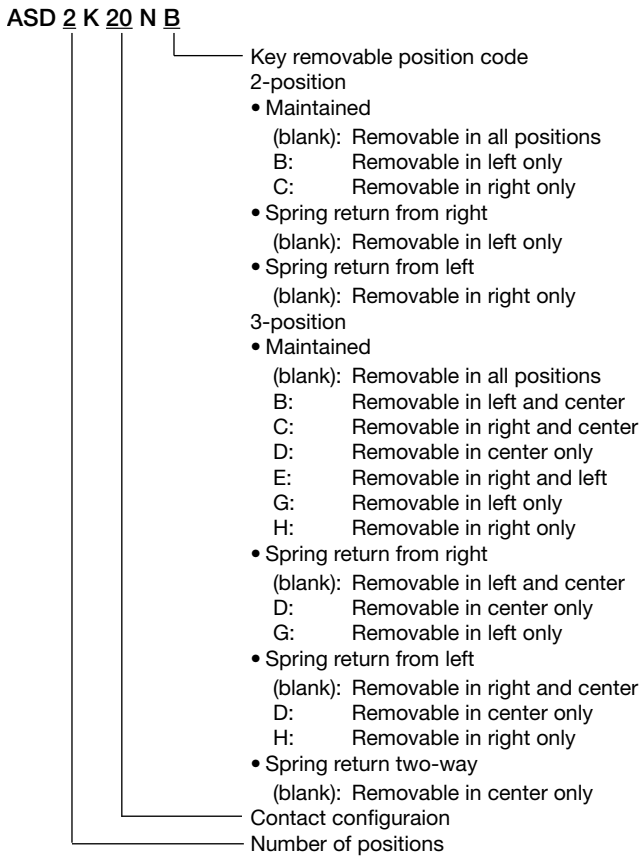











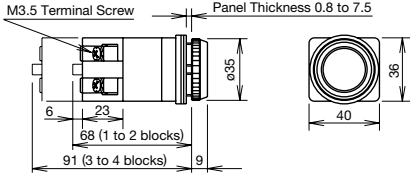



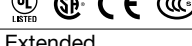
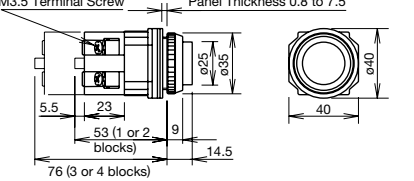

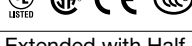
Note:

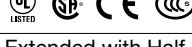
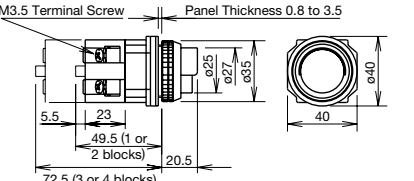
- The key cannot be removed in the return position.

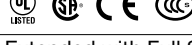
# ø30 ø30 Diecast Zinc Series Pushbuttons

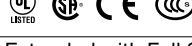
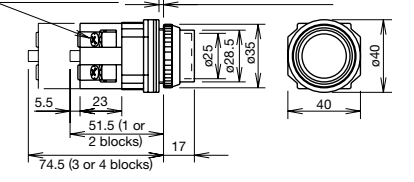

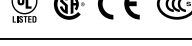











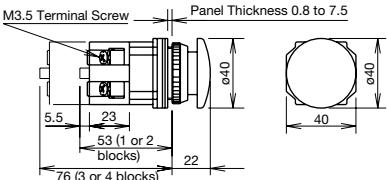









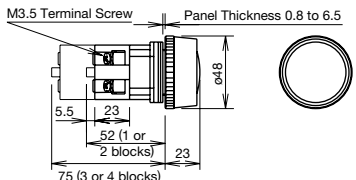









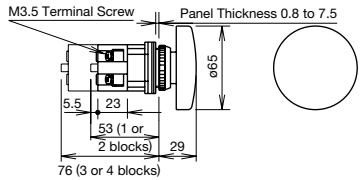

## Flush / Extended / Extended with Half Shroud / Extended with Full Shroud

Shape	Operation	Contact	Part No.	① Button Color Code	Dimensions (mm)
Flush ABD1  	Momentary	1NO	ABD110N①	Black (B), green (G), and red (R) buttons are supplied with each unit.	
		1NC	ABD101N①		
		1NO-1NC	ABD111N①		
		2NO	ABD120N①		
		2NC	ABD102N①		
		2NO-2NC	ABD122N①		
Flush AOD1  	Maintained	1NO	AOD110N①	Specify S, Y, or W when a blue, yellow, or white button is required.	
		1NC	AOD101N①		
		1NO-1NC	AOD111N①		
		2NO	AOD120N①		
		2NC	AOD102N①		
		2NO-2NC	AOD122N①		
Extended ABD2  	Momentary	1NO	ABD210N①		
		1NC	ABD201N①		
		1NO-1NC	ABD211N①		
		2NO	ABD220N①		
		2NC	ABD202N①		
		2NO-2NC	ABD222N①		
Extended AOD2  	Maintained	1NO	AOD210N①		
		1NC	AOD201N①		
		1NO-1NC	AOD211N①		
		2NO	AOD220N①		
		2NC	AOD202N①		
		2NO-2NC	AOD222N①		
Extended with Half Shroud ABGD2  	Momentary	1NO	ABGD210N①	Specify a button color code in place of ① in the Part No.	
		1NC	ABGD201N①		
		1NO-1NC	ABGD211N①		
		2NO	ABGD220N①		
		2NC	ABGD202N①		
		2NO-2NC	ABGD222N①		
Extended with Half Shroud AOGD2  	Maintained	1NO	AOGD210N①	B: black G: green R: red S: blue W: white Y: yellow	
		1NC	AOGD201N①		
		1NO-1NC	AOGD211N①		
		2NO	AOGD220N①		
		2NC	AOGD202N①		
		2NO-2NC	AOGD222N①		
Extended with Full Shroud ABFD2  	Momentary	1NO	ABFD210N①		
		1NC	ABFD201N①		
		1NO-1NC	ABFD211N①		
		2NO	ABFD220N①		
		2NC	ABFD202N①		
		2NO-2NC	ABFD222N①		
Extended with Full Shroud AOFD2  	Maintained	1NO	AOFD210N①		
		1NC	AOFD201N①		
		1NO-1NC	AOFD211N①		
		2NO	AOFD220N①		
		2NC	AOFD202N①		
		2NO-2NC	AOFD222N①		

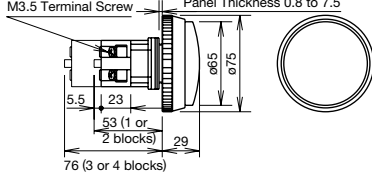
- Round bezel and shroud (metal): Chrome-plated
- Pushbuttons with one or three contact blocks contain a dummy block
- Other contact configurations are also available. See page 72.

# ø30 Diecast Zinc series Pushbuttons ø30



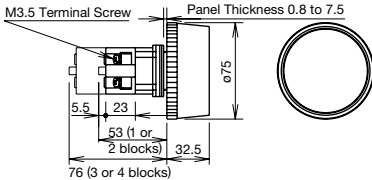





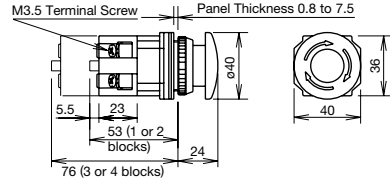

## Mushroom / Jumbo Mushroom Pushbuttons

Shape	Operation	Contact	Part No.	① Button Color Code	Dimensions (mm)	
Mushroom ABD3     	Momentary	1NO	ABD310N①	B: black G: green R: red W: white Y: yellow		
		1NC	ABD301N①			
		1NO-1NC	ABD311N①			
		2NO	ABD320N①			
		2NC	ABD302N①			
		2NO-2NC	ABD322N①			
Mushroom AOD3     	Maintained	1NO	AOD310N①			
		1NC	AOD301N①			
		1NO-1NC	AOD311N①			
		2NO	AOD320N①			
		2NC	AOD302N①			
		2NO-2NC	AOD322N①			
Mushroom with Full Shroud ABGD3     	Momentary	1NO	ABGD310N①	B: black G: green R: red W: white Y: yellow		
		1NC	ABGD301N①			
		1NO-1NC	ABGD311N①			
		2NO	ABGD320N①			
		2NC	ABGD302N①			
		2NO-2NC	ABGD322N①			
Mushroom with Full Shroud AOGD3     	Maintained	1NO	AOGD310N①			
		1NC	AOGD301N①			
		1NO-1NC	AOGD311N①			
		2NO	AOGD320N①			
		2NC	AOGD302N①			
		2NO-2NC	AOGD322N①			
Jumbo Mushroom ABD4     	Momentary	1NO	ABD410N①	B: black DG: dark green DR: dark red G: green R: red Y: yellow		
		1NC	ABD401N①			
		1NO-1NC	ABD411N①			
		2NO	ABD420N①			
		2NC	ABD402N①			
		2NO-2NC	ABD422N①			
Jumbo Mushroom with Shallow Shroud ABGD4     	Momentary	1NO	ABGD410N①		B: black DG: dark green DR: dark red G: green R: red Y: yellow	
		1NC	ABGD401N①			
		1NO-1NC	ABGD411N①			
		2NO	ABGD420N①			
		2NC	ABGD402N①			
		2NO-2NC	ABGD422N①			
Jumbo Mushroom with Deep Shroud ABFD4     	Momentary	1NO	ABFD410N①	B: black DG: dark green DR: dark red G: green R: red Y: yellow		
		1NC	ABFD401N①			
		1NO-1NC	ABFD411N①			
		2NO	ABFD420N①			
		2NC	ABFD402N①			
		2NO-2NC	ABFD422N①			

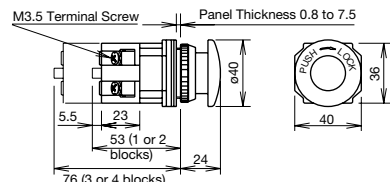
- Specify a button color code in place of ① in the Part No.
- Round bezel and shroud (metal): Chrome-plated
- Pushbuttons with one or three contact blocks contain a dummy block
- Other contact configurations are also available. See page 72.

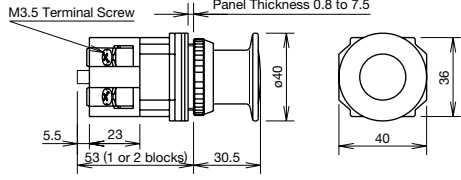
# ø30 ø30 Diecast Zinc Series Pushbuttons

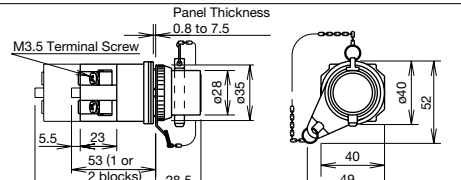

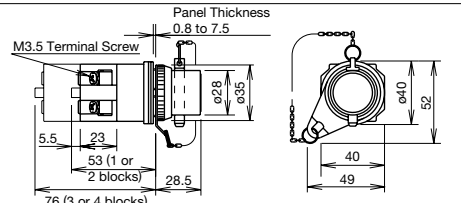







## Pushlock Turn Reset / Push Turn Lock / Pull / Push-Pull / Pin Lock Pushbuttons

Shape	Contact	Part No.	① Button Color Code	Dimensions (mm)
<b>Mushroom Pushlock Turn Reset</b> AVD3  	1NO	AVD310N①	R: red Y: yellow	
	1NC	AVD301N①		
	1NO-1NC	AVD311N①		
	2NO	AVD320N①		
	2NC	AVD302N①		
<b>Mushroom Push Turn Lock</b> AJD3  	1NO	AJD310N①	B: black G: green R: red Y: yellow	
	1NC	AJD301N①		
	1NO-1NC	AJD311N①		
	2NO	AJD320N①		
	2NC	AJD302N①		
<b>Mushroom Pull</b> AZD3  	1NO	AZD310N①	B: black G: green R: red S: blue Y: yellow	
	1NO-1NC	AZD311N①		
	2NO	AZD320N①		
	2NC	AZD302N①		
<b>Mushroom Push-Pull</b> AYD31  	1NO-1NC	AYD3111N①	B: black G: green R: red S: blue Y: yellow	
	2NO	AYD3120N①		
	2NC	AYD3102N①		
<b>Pin Lock</b> ABD8P  	1NO	ABD8P10N①		
	1NC	ABD8P01N①		
	1NO-1NC	ABD8P11N①		
	2NO	ABD8P20N①		
	2NC	ABD8P02N①		
	2NO-2NC	ABD8P22N①		







- Specify a button color code in place of ① in the Part No.
- Round bezel (metal): Chrome-plated
- Pushbuttons with one or three contact blocks contain a dummy block.
- Other contact configurations are also available. See page 72.
- **Pushlock Turn Reset:** Button is maintained when pressed and is reset when turned clockwise. Red buttons only.
- **Note:** AVD3 pushlock turn reset switches cannot be used as emergency stop switches. When emergency stop switches are required, use XN or HN series emergency stop switches (ISO 13850 and IEC 60947-5-5 compliant).
- **Push Turn Lock:** Button is locked when turned clockwise in the depressed position and is reset when turned counterclockwise.
- **Pull:** Pulling the button operates the contacts. Up to 2 contact blocks (1 layer) can be mounted on pull switches.
- **Push-Pull:** Button is maintained in both depressed and reset positions. Up to 2 contact blocks (1 layer) can be mounted on AYD31 push-pull switches.
- **Note:** AYD31 push-pull switches cannot be used as emergency stop switches. When emergency stop switches are required, use the HN1E series emergency stop switches (ISO 13850 and IEC 60947-5-5 compliant).
- **Pin Lock:** Button can be locked in either depressed or reset position by inserting the pin. Pad lock with a ø5mm pin can also be used to lock the button.

### Contact Operation

#### Pull Switch (Spring Return)

Contact	AZD3	
	Normal	Pull
1NO		
1NC		
1NO-1NC		
2NO		
2NC		





#### Push-Pull Switch (Maintained)

Contact	AYD31	
	Push	Pull
1NO-1NC		
2NO		
2NC		

Note: Pull and push-pull switches can have a maximum of two contact blocks.

# ø30 Diecast Zinc Series Pilot Lights ø30

## APD1 / APDE1 Dome Pilot Lights

Shape	Lamp	Lamp Receptacle	Part No.	② Lens/LED Color Code	Applicable Lamp
Dome APD1 APDE1      	Without Lamp	BA9S	APD199N②	A: amber      C: clear G: green      R: red S: blue        W: white DNY: yellow	See page 17 for lamps.
	LED	BA9S	APD1③DN②	A: amber      G: green PW: pure white R: red S: blue        W: white Y: yellow	

### Operating Voltage Code

Specify an operating voltage code in place of ③ in the Part No.

③ Operating Voltage Code	Input
66: 6V AC/DC 11: 12V AC/DC 22: 24V AC/DC	Full Voltage
16: 100/110V AC 126: 120V AC 26: 200/220V AC 246: 240V AC 386: 380V AC 46: 400/440V AC	Transformer

- Specify a lens/LED color code in place of ② in the Part No.
- Use a pure white (PW) LED for yellow (Y) illumination..

### Dimensions

#### Full Voltage

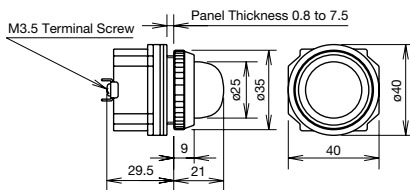

#### Transformer

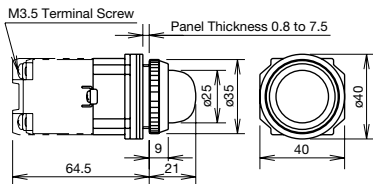

All dimensions in mm.

# ø30 ø30 Diecast Zinc Series Illuminated Pushbuttons

## ALD2 / AOLD2 Round Extended Illuminated Pushbuttons

Shape	Lamp Receptacle	Operation	Lamp	Contact	Part No.	Applicable Lamp
Round Extended ALD2 AOLD2  	BA9S	Momentary	Without Lamp	1NO-1NC	ALD29911N②	See page 17 for lamps.
				2NO	ALD29920N②	
				2NC	ALD29902N②	
			LED	1NO-1NC	ALD2③11DN②	
				2NO	ALD2③20DN②	
				2NC	ALD2③02DN②	
		Maintained	Without Lamp	1NO-1NC	AOLD29911N②	
				2NO	AOLD29920N②	
				2NC	AOLD29902N②	
			LED	1NO-1NC	AOLD2③11DN②	
				2NO	AOLD2③20DN②	
				2NC	AOLD2③02DN②	

### Color Code and Operating Voltage Code

Specify a code in place of ② and ③ in the Part No.

② Lens/LED Color Code		③ Operating Voltage Code	Input
Without Lamp	LED		
A: amber C: clear G: green R: red S: blue W: white DNY: yellow	A: amber G: green PW: pure white R: red S: blue W: white Y: yellow	66: 6V AC/DC 11: 12V AC/DC 22: 24V AC/DC  16: 100/110V AC 126: 120V AC 26: 200/220V AC 246: 240V AC 386: 380V AC 46: 400/440V AC	Full Voltage  Transformer

- Use a pure white (PW) LED for yellow (Y) illumination..

### Dimensions

ALD2/AOLD2  
Full Voltage

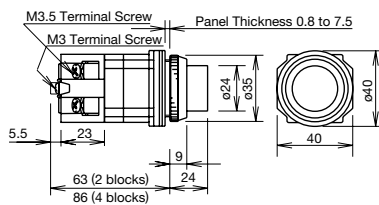

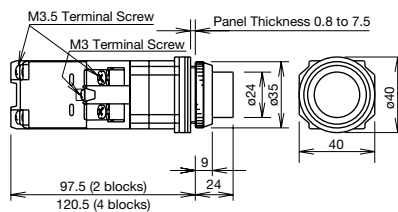

ALD2/AOLD2  
BA9S/Transformer



All dimensions in mm.

# ø30 Diecast Zinc Series Illuminated Pushbuttons ø30

## ALFD2 / AOLFD2 Round Extended with Full Shroud Illuminated Pushbuttons

Shape	Lamp Receptacle	Operation	Lamp	Contact	Part No.	Applicable Lamp
Round Extended with Full Shroud ALFD2 AOLFD2      	BA9S	Momentary	Without Lamp	1NO-1NC	ALFD29911N②	See page 17 for lamps.
				2NO	ALFD29920N②	
				2NC	ALFD29902N②	
			LED	1NO-1NC	ALFD2③11DN②	
				2NO	ALFD2③20DN②	
				2NC	ALFD2③02DN②	
		Maintained	Without Lamp	1NO-1NC	AOLFD29911N②	
				2NO	AOLFD29920N②	
				2NC	AOLFD29902N②	
			LED	1NO-1NC	AOLFD2③11DN②	
				2NO	AOLFD2③20DN②	
				2NC	AOLFD2③02DN②	

### Color Code and Operating Voltage Code

Specify a code in place of ② and ③ in the Part No.

② Lens/LED Color Code		③ Operating Voltage Code	Input
Without Lamp	LED		
A: amber C: clear G: green R: red S: blue W: white DNY: yellow	A: amber G: green PW: pure white R: red S: blue W: white Y: yellow	66: 6V AC/DC 11: 12V AC/DC 22: 24V AC/DC  16: 100/110V AC 126: 120V AC 26: 200/220V AC 246: 240V AC 386: 380V AC 46: 400/440V AC	Full Voltage      Transformer

- Use a pure white (PW) LED for yellow (Y) illumination.

### Dimensions

ALFD2/AOLFD2  
Full Voltage

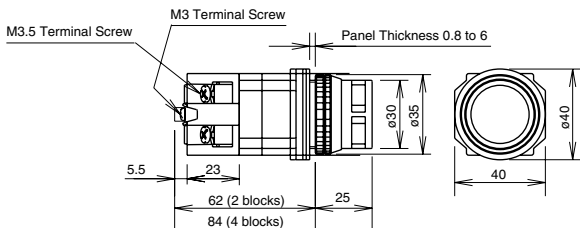

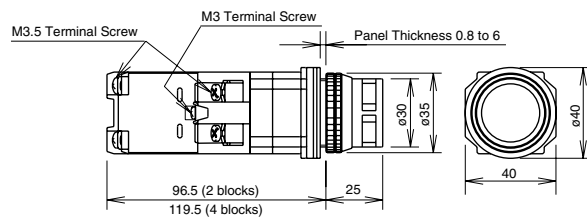

ALFD2/AOLFD2  
Transformer



All dimensions in mm.

# ø30 ø30 Diecast Zinc Series Illuminated Pushbuttons

## ALD3 / AOLD3 Mushroom (ø40) Illuminated Pushbuttons

Shape	Lamp Receptacle	Operation	Lamp	Contact	Part No.	Applicable Lamp
ø40 Mushroom ALD3 AOLD3    	BA9S	Momentary	Without Lamp	1NO-1NC	ALD39911DN②	See page 17 for lamps.
				2NO	ALD39920DN②	
				2NC	ALD39902DN②	
			LED	1NO-1NC	ALD3③11DN②	
				2NO	ALD3③20DN②	
				2NC	ALD3③02DN②	
		Maintained	Without Lamp	1NO-1NC	AOLD39911DN②	
				2NO	AOLD39920DN②	
				2NC	AOLD39902DN②	
			LED	1NO-1NC	AOLD3③11DN②	
				2NO	AOLD3③20DN②	
				2NC	AOLD3③02DN②	

### Color Code and Operating Voltage Code

Specify a code in place of ② and ③ in the Part No.

② Lens/LED Color Code	③ Operating Voltage Code	Input
A: amber G: green R: red W: white Y: yellow	66: 6V AC/DC 11: 12V AC/DC 22: 24V AC/DC	Full Voltage
Use a pure white (PW) LED for yellow (Y) illumination..	16: 100/110V AC 126: 120V AC 26: 200/220V AC 246: 240V AC 386: 380V AC 46: 400/440V AC	Transformer

### Dimensions

ALD3/AOLD3  
Full Voltage

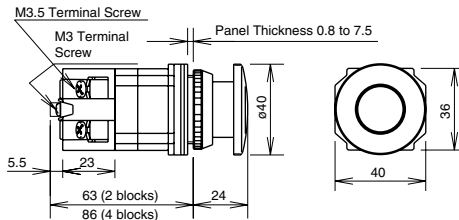

ALD3/AOLD3  
Transformer

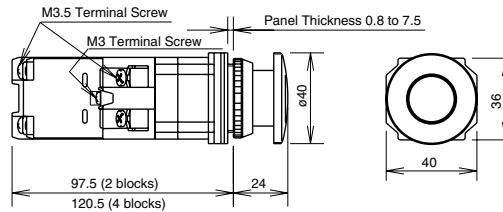





All dimensions in mm.



# ø30 Diecast Zinc Series Illuminated Pushbuttons ø30

## AVLD3/ AVLDE3 Mushroom Pushlock Turn Reset Illuminated Pushbuttons

Shape	Lamp Receptacle	Lamp	Contact	Part No.	Applicable Lamp
Mushroom Pushlock Turn Reset AVLD3 AVLDE3      	BA9S	Without Lamp	1NO-1NC	AVLD39911NR	See page 17 for lamps.
			2NO	AVLD39920NR	
			2NC	AVLD39902NR	
		LED	1NO-1NC	AVLD3③11DNR	
			2NO	AVLD3③20DNR	
			2NC	AVLD3③02DNR	

### Color Code and Operating Voltage Code

Specify a code in place of ② and ③ in the Part No.

③ Operating Voltage Code	Input
66: 6V AC/DC 11: 12V AC/DC 22: 24V AC/DC	Full Voltage
16: 100/110V AC 126: 120V AC 26: 200/220V AC 246: 240V AC 386: 380V AC 46: 400/440V AC	Transformer

Note: When ordering 6V, 12V, 24V AC/DC units, specify "E" before the operating voltage code.  
Example: AVLDE3③11NR

- Color code: R (red)
- **Pushlock Turn Reset:** Lens is maintained when pressed and is reset when turned clockwise. Red lens only.

Note: AVLD3 and AVLDE3 pushlock turn reset switches cannot be used as emergency stop switches. When emergency stop switches are required, use XN or HN series emergency stop switches (ISO 13850 and IEC 60947-5-5 compliant).

### Dimensions

AVLD3  
BA9S/Full Voltage

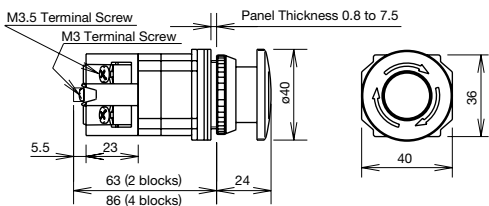

AVLD3  
BA9S/Transformer

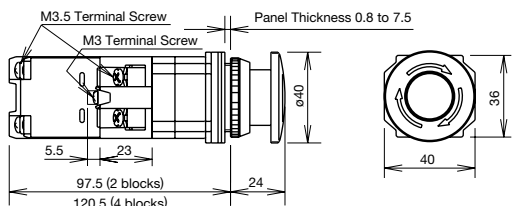

All dimensions in mm.

# ø30 ø30 Diecast Zinc Series Selector Switches

## ASD Selector Switches (Knob Operator)

No. of Positions	ASD									
	Contact Configuration		Contact Block		Operator Position		Maintained	Spring Return from Right	Spring Return from Left	
90° 2-position	Mounting Position	Contact	L	R		L	R	L	R	
1NO-1NC	2	1	NO		●	ASD211N	ASD2111N	ASD2211N *		
		2	NC	●						
2NO	1	NO		●		ASD220N	ASD2120N	ASD2220N *		
		2	NO		●					
2NO-2NC	2	1	NO		●	ASD222N	ASD2122N	ASD2222N *		
		2	NC	●						
		3	NO		●					
	4	1	NO		●					
		2	NC	●						

No. of Positions	ASD										
	Contact Configuration		Contact Block		Operator Position		Maintained	Spring Return from Right	Spring Return from Left	Spring Return Two-way	
45° 3-position	Mounting Position	Contact	L	C	R	L	C	R	L	C	R
4NO	2	1	NO	●		ASD340N		ASD3240N	ASD3340N		
		2	NO		●						
		3	NO	●							
		4	NO		●						
2NO-2NC	3	1	NO	●		ASD322N		ASD3222N	ASD3322N		
		2	NO		●						
		3	NC		●						
		4	NC	●							
2NC	1	NC		●		ASD302N	ASD3102N	ASD3202N	ASD3302N		
		2	NC	●							
4NC	2	1	NC		●	ASD304N		ASD3204N	ASD3304N		
		2	NC	●							
		3	NC		●						
		4	NC	●							

- Knob: Black
- Round bezel (metal): Chrome-plated
- Selector switches with one contact block contain a dummy block.
- On the 2-position selector switches marked with \* above, the contact operation is reversed as follows.

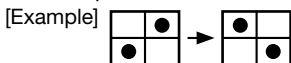

### Contact Block Mounting Position and Contact Configuration Chart



		Left	Center	Right	
		L	C	R	Operator Position
1	NO		●		
2	NO			●	
3	NC			●	
4	NC	●			

### Dimensions

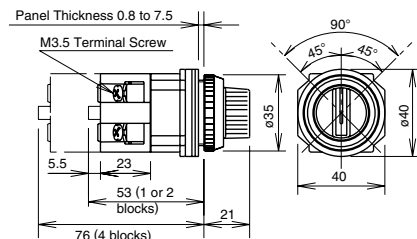

All dimensions in mm.

# ø30 Diecast Zinc Series Selector Switches ø30

## ASD□L Selector Switches (Lever Operator)

No. of Positions	ASD□L		Operator Position			Maintained	Spring Return from Right	Spring Return from Left	
	Contact Configuration	Contact Block	L	R					
90° 2-position	1NO	1 NO		●		ASD2L10N			—
		2 Dummy							
	1NO-1NC	1 NO		●		ASD2L11N			
		2 NC	●						
	2NO	1 NO			●	ASD2L20N			
		2 NO			●				
	2NO-2NC	1 NO		●		ASD2L22N			
		2 NC	●						
		3 NO			●				
		4 NC	●						
45° 3-position	2NO	1 NO	●			ASD3L20N			Spring Return Two-way 
		2 NO			●				
	4NO	1 NO	●			ASD3L40N			
		2 NO			●				
		3 NO	●						
		4 NO			●				
	2NO-2NC	1 NO	●			ASD3L22N			
		2 NO			●				
		3 NC	●						
		4 NC			●				
	2NC	1 NC	●			ASD3L02N			
		2 NC			●				
	4NC	1 NC	●			ASD3L04N			
		2 NC			●				
		3 NC	●						
		4 NC			●				

- Lever: Black
- Round bezel (metal): Chrome-plated
- Selector switches with one contact block contain a dummy block.
- On the 2-position selector switches marked with \* above, the contact operation is reversed as follows.

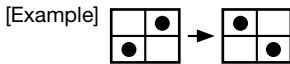

### Contact Block Mounting Position and Contact Configuration Chart

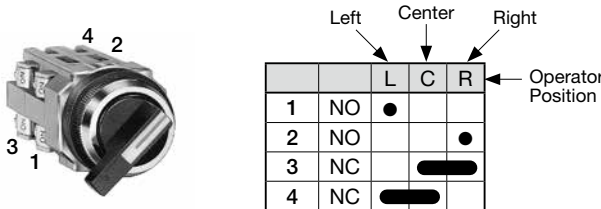

### Dimensions

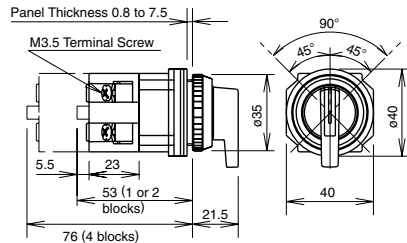

All dimensions in mm.

# ø30 ø30 Diecast Zinc Series Selector Switches

## ASD□K Key Selector Switches

No. of Positions	ASD□K											
	Contact Configuration	Contact Block	Operator Position		Maintained	Spring Return from Right	Spring Return from Left					
90° 2-position	Mounting Position	Contact	L	R	L	R	L	R				
	90° 2-position	1NO	1	NO		●				ASD2K10N	ASD21K10N	ASD22K10N *
2			Dummy									
1NO-1NC		1	NO		●				ASD2K11N	ASD21K11N	ASD22K11N *	
		2	NC	●								
2NO		1	NO		●				ASD2K20N	ASD21K20N	ASD22K20N *	
		2	NO		●							
2NO-2NC		1	NO		●				ASD2K22N	ASD21K22N	ASD22K22N *	
		2	NC	●								
	3	NO		●								
	4	NC	●									
45° 3-position	Contact Configuration	Contact Block	Operator Position			Maintained	Spring Return from Right	Spring Return from Left	Spring Return Two-way			
	Mounting Position	Contact	L	C	R	L	C	R	L	C	R	
45° 3-position	2NO	1	NO	●					ASD3K20N	ASD31K20N	ASD32K20N	ASD33K20N
		2	NO			●						
	4NO	1	NO	●					ASD3K40N	ASD31K40N	ASD32K40N	ASD33K40N
		2	NO			●						
		3	NO	●								
		4	NO			●						
	2NO-2NC	1	NO	●					ASD3K22N	ASD31K22N	ASD32K22N	ASD33K22N
		2	NO			●						
		3	NC			●						
		4	NC	●								
	2NC	1	NC			●			ASD3K02N	ASD31K02N	ASD32K02N	ASD33K02N
		2	NC	●								
	4NC	1	NC			●			ASD3K04N	ASD31K04N	ASD32K04N	ASD33K04N
		2	NC	●								
		3	NC			●						
		4	NC	●								

- Cylinder: Black
- Round bezel (metal): Chrome-plated
- On the spring-returned, the keys can be released only from the maintained positions. On the maintained, the key can be released from every position. Key retained positions are also available. See page 73.
- Key selector switches are supplied with two standard keys.
- Key selector switches with one contact block contain a dummy block.
- On the 2-position selector switches marked with \* above, the contact operation is reversed as follows.

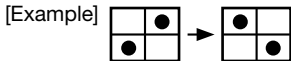

### Contact Block Mounting Position and Contact Configuration Chart

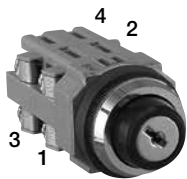

		Left	Center	Right	Operator Position
1	NO	●			
2	NO			●	
3	NC			●	
4	NC	●			

### Dimensions

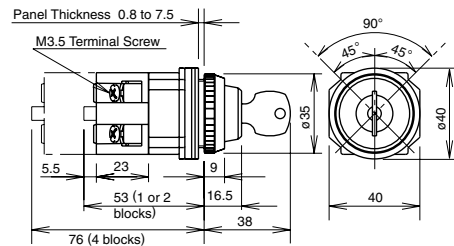

All dimensions in mm.

# ø30 Diecast Zinc series Illuminated Selector Switches ø30

## ASLD Illuminated Selector Switches

### 90° 2-position

ASLD (Base BA9S)



Contact Configuration	Contact Block		Operator Position		Lamp	Maintained	Spring Return from Right	Spring Return from Left
	Mounting Position	Contact	L	R		L R	L R	L R
1NO-1NC	1	NO		●	Without Lamp	ASLD29911N②	ASLD219911N②	ASLD229911N② *
	2	NC	●		LED	ASLD2③11DN②	ASLD21③11DN②	ASLD22③11DN② *
2NO	1	NO		●	Without Lamp	ASLD29920N②	ASLD219920N②	ASLD229920N② *
	2	NO		●	LED	ASLD2③20DN②	ASLD21③20DN②	ASLD22③20DN② *
2NO-2NC	1	NO		●	Without Lamp	ASLD29922N②	ASLD219922N②	ASLD229922N② *
	2	NC	●					
	3	NO		●	LED	ASLD2③22DN②	ASLD21③22DN②	ASLD22③22DN② *
	4	NC	●					

### Color Code and Operating Voltage Code

Specify a code in place of ② or ③ in the Part No.

② Lens/LED Color Code	③ Operating Voltage Code	Input
A: amber G: green R: red S: blue W: white Y: yellow	66: 6V AC/DC 11: 12V AC/DC 22: 24V AC/DC	Full voltage
Use a pure white (PW) LED for yellow (Y) illumination.	16: 100/110V AC 136: 120V AC 26: 200/220V AC 256: 240V AC 386: 380V AC 46: 400/440V AC	Transformer

• On the 2-position selector switches marked with \* above, the contact operation is reversed as follows.

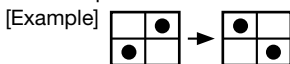

### Contact Block Mounting Position and Contact Configuration Chart

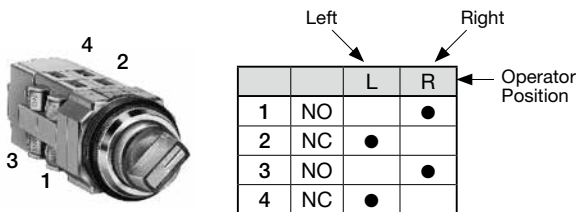

### Dimensions

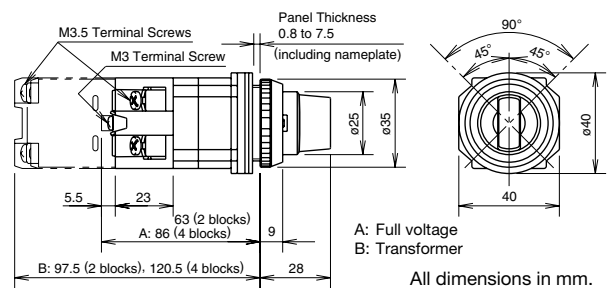

# ø30 ø30 Diecast Zinc Series Illuminated Selector Switches

## ASLD Illuminated Selector Switches

### 45° 3-position

Contact Configuration	Contact Block		Operator Position			Lamp	Maintained	Spring Return from Right	Spring Return from left	Spring Return Two-way
	Mounting Position	Contact	L	C	R					
2NO	1	NO	●			Without Lamp	ASLD39920N②	ASLD319920N②	ASLD329920N②	ASLD339920N②
	2	NO			●	LED	ASLD3③20DN②	ASLD31③20DN②	ASLD32③20DN②	ASLD33③20DN②
2NC	1	NC		■		Without Lamp	ASLD39902N②	ASLD319902N②	ASLD329902N②	ASLD339902N②
	2	NC		■		LED	ASLD3③02DN②	ASLD31③02DN②	ASLD32③02DN②	ASLD33③02DN②
2NO-2NC	1	NO	●			Without Lamp	ASLD39922N②	ASLD319922N②	ASLD329922N②	ASLD339922N②
	2	NO			●					
	3	NC		■		LED	ASLD3③22DN②	ASLD31③22DN②	ASLD32③22DN②	ASLD33③22DN②
	4	NC		■						
4NO	1	NO	●			Without Lamp	ASLD39940N②	ASLD319940N②	ASLD329940N②	ASLD339940N②
	2	NO			●					
	3	NO	●			LED	ASLD3③40DN②	ASLD31③40DN②	ASLD32③40DN②	ASLD33③40DN②
	4	NO			●					
4NC	1	NC		■		Without Lamp	ASLD39904N②	ASLD319904N②	ASLD329904N②	ASLD339904N②
	2	NC		■						
	3	NC		■		LED	ASLD3③04DN②	ASLD31③04DN②	ASLD32③04DN②	ASLD33③04DN②
	4	NC		■						

### Color Code and Operating Voltage Code

Specify a code in place of ② or ③ in the Part No.

② Lens/LED Color Code	③ Operating Voltage Code	Input Type
A: amber G: green R: red S: blue W: white Y: yellow	66: 6V AC/DC 11: 12V AC/DC 22: 24V AC/DC	Full voltage
Use a pure white (PW) LED for yellow (Y) illumination.	16: 100/110V AC 136: 120V AC 26: 200/220V AC 256: 240V AC 386: 380V AC 46: 400/440V AC	Transformer

### Contact Block Mounting Position and Contact Configuration Chart

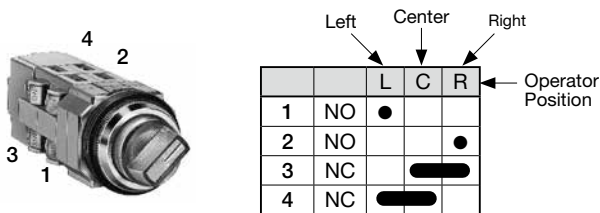



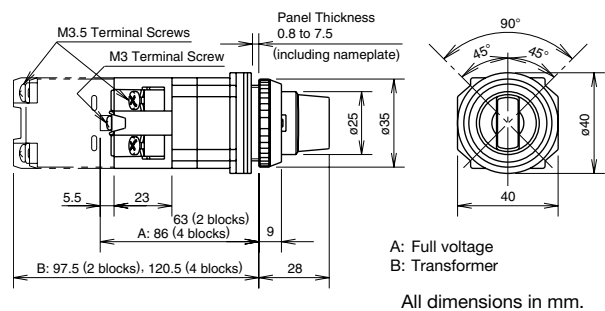





### Dimensions

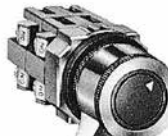

# ø30 Diecast Zinc series Selector Pushbuttons ø30

## ASBD2 Ring Operator / ASBD2L Lever Operator Selector Pushbuttons

Shape	Contact Configuration	Circuit Code	Contact Block		Ring/Lever				Ring Operator	Lever Operator	Color	
					Pushbutton							
					Mounting Position	Contact	Normal	Push				Normal
<div style="display: flex; flex-direction: column; align-items: center;"> <div style="text-align: center;">  <p>Ring Operator (90° 2-Position) ASBD2</p> </div> <div style="display: flex; justify-content: space-around; width: 100%;">     </div> <div style="text-align: center; margin-top: 20px;">  <p>Lever Operator (90° 2-Position) ASBD2L</p> </div> <div style="display: flex; justify-content: space-around; width: 100%;">     </div> </div>	1NO-1NC	A03	1	NO		●		●	ASBD211N-A03①	ASBD2L11N-A03①	B: black G: green R: red Y: yellow	
			2	NC	●							
		G03	1	NO		●			Blocked	ASBD211N-G03①		ASBD2L11N-G03①
			2	NC	●		●					
	A08	1	NO		●		●		ASBD222N-A08①	ASBD2L22N-A08①		
		2	NC	●								
		3	NO		●		●					
		4	NC	●								
	C10	1	NO			●		●	ASBD222N-C10①	ASBD2L22N-C10①		
		2	NO					●				
		3	NC	●								
		4	NC	●	●							
	D10	1	NO			●			ASBD222N-D10①	ASBD2L22N-D10①		
		2	NO					●				
		3	NC	●		●	●					
		4	NC	●	●							
	E10	1	NO			●			ASBD222N-E10①	ASBD2L22N-E10①		
		2	NO					●				
		3	NC									●
		4	NC	●	●							
F10	1	NO			●			ASBD222N-F10①	ASBD2L22N-F10①			
	2	NO			●							
	3	NC				●						
	4	NC	●									
G10	1	NO			●			ASBD222N-G10①	ASBD2L22N-G10①			
	2	NO			●							
	3	NC	●			●	Blocked					
	4	NC	●			●						

- Specify a button color code in place of ① in the Part No.
- Ring/Lever (Metal): Chrome-plated

**Notes:**

1. Circuit Code G: The pushbutton does not operate when the ring or lever operator is turned to the right position.
2. Circuit Codes E and F: The right and left NC contact blocks on circuit code E or F may overlap each other while turning the ring or lever operator. The NO and NC contact blocks on circuit code F may overlap each other while pressing the button.
3. When using the selector pushbutton, do not turn the ring or lever operator with the pushbutton depressed. Otherwise, damage or failure may be caused.
4. When installing the lever operator, make sure that the lever is not in the horizontal position. Otherwise, shock resistance may be degraded.

**Contact Block Mounting Position**



**Dimensions**

Ring Operator  
(90° 2-position)  
ASBD2

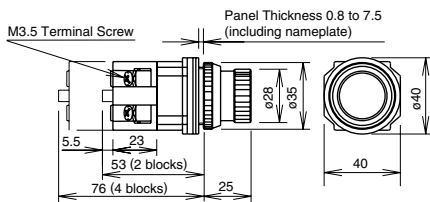

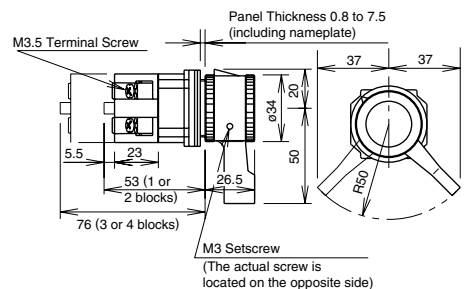

Lever Operator  
(90° 2-position)  
ASBD2L





# ø30 ø30 Diecast Zinc Series Accessories and Replacement Parts

## Accessories (For Diecast Zinc Series Only)

For other accessories, see pages 59 to 68.

Shape	Material	Part No.	Ordering No.	Package Quantity	Description
 Flush (Octagonal)      Extended (Octagonal)	Chrome-plated	OG-81	OG-81PN02	2	• Cannot be used with half-shrouds.
		OG-82	OG-82	1	
Spare Key 	Metal	TW-SK-0	TW-SK-0PN02	2	• For key selector switches

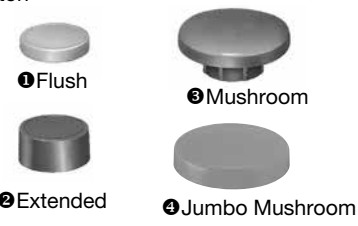
## Maintenance Parts (For Diecast Zinc Series Only)

Shape	Specification	Part No.	Ordering No.	Package Quantity	Description
 ① Flush      ③ Mushroom ② Extended      ④ Jumbo Mushroom	Polyacetal	① ABN1BN-①	ABN1BN-①PN05	5	Specify a color code in place of ①. B (black), G (green), R (red), S (blue), W (white), Y (yellow) • Above colors are used for ø30 diecast zinc switches & pilot lights (light colored operator units).
		② ABN2BN-①	ABN2BN-①PN05	5	
		③ ABN3BN-①	ABN3BN-①PN02	2	
		④ ABN4BN-①	ABN4BN-①	1	
Dummy Block 	Polyamide	BST-D	BST-DPN10	10	• Used for 1NO or 1NC contact blocks. • Snaps on to the operator unit.
Selector Operator ① Knob      ② Lever      ③ Color Insert 	Polyacetal	① ASNHT-①	ASNHT-①PN02	2	Specify a color code in place of ①. B (blue), G (green), R (red)
		② ASNHL-①	ASNHL-①PN02		
		③ TW-HC1①	TW-HC1①PN05	5	Specify a color code in place of ①. B (black), G (green), R (red), S (blue), W (white), Y (yellow)

## Safety Precautions

- Turn off the power to the ø30 diecast zinc switches & pilot lights before starting installation, removal, wiring, maintenance, and starting installation, removing, wiring, maintenance, and inspection of the products. Failure to turn power off may cause electrical shocks or fire hazard.
- To avoid a burn on your hand, use the lamp holder tool when replacing lamps.
- For wiring, use wires of a proper size to meet the voltage and current requirements. Tighten the M3.5 terminal screws to a tightening torque of 1.0 to 1.3 N·m. Failure to tighten terminal screws may cause overheat and fire.

## Instructions

### Tightening Torque for Terminal Screws

Tighten the M3.5 terminal screws to a torque of 1.0 to 1.3 N·m.

### Replacement of Lamps

Lamps can be replaced by using the lamp holder tool (OR-55) from the front of the panel.

#### • How to remove

To remove, slip the lamp holder tool onto the lamp head lightly. Then push slightly, and turn the lamp holder tool counterclockwise.

#### • How to install

To install, insert the lamp head into the lamp holder tool. Place the pins on the lamp base to the grooves in the lamp socket. Inset the lamp and turn it clockwise.

### Installation of LED Illuminated Units

- When using full voltage LED illuminated units, provide protection against electrical noise, if necessary. See page 70 for notes on LED illuminated units.



OR-55



# IDEC CORPORATION

#### Head Office

6-64, Nishi-Miyahara-2-Chome, Yodogawa-ku, Osaka 532-0004, Japan

<b>USA</b>	IDEC Corporation	Tel: +1-408-747-0550	opencontact@idec.com
<b>Germany</b>	IDEC Elektrotechnik GmbH	Tel: +49-40-25 30 54 - 0	service@eu.idec.com
<b>Singapore</b>	IDEC Izumi Asia Pte. Ltd.	Tel: +65-6746-1155	info@sg.idec.com
<b>Thailand</b>	IDEC Asia (Thailand) Co., Ltd	Tel: +66-2-392-9765	sales@th.idec.com
<b>Australia</b>	IDEC Australia Pty. Ltd.	Tel: +61-3-8523-5900	sales@au.idec.com
<b>Taiwan</b>	IDEC Taiwan Corporation	Tel: +886-2-2698-3929	service@tw.idec.com

<b>Hong Kong</b>	IDEC Izumi (H.K.) Co., Ltd.	Tel: +852-2803-8989	info@hk.idec.com
<b>China/Shanghai</b>	IDEC (Shanghai) Corporation	Tel: +86-21-6135-1515	idec@cn.idec.com
<b>China/Shenzhen</b>	IDEC (Shenzhen) Corporation	Tel: +86-755-8356-2977	idec@cn.idec.com
<b>China/Beijing</b>	IDEC (Beijing) Corporation	Tel: +86-10-6581-6131	idec@cn.idec.com
<b>Japan</b>	IDEC Corporation	Tel: +81-6-6398-2527	marketing@idec.co.jp

 [www.idec.com](http://www.idec.com)

Specifications and other descriptions in this brochure are subject to change without notice.  
2017 IDEC Corporation, All Rights Reserved.

EP1429-13 JUNE 2017

