

# Rigid Nonmetallic Sch. 40 Elbows - Standard Radius

## Schedule 40 30° Elbow - Bell End

Conforms to UL651 and NEMA TC3

Material is Rigid PVC

Bend Tolerance is  $\pm 2^\circ$

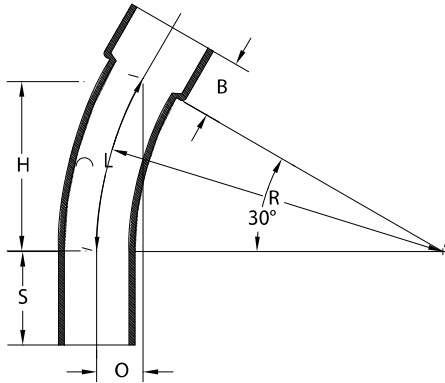

Part Number	Trade Size	Carton Qty.	"R"	"O"	"H"	"S" MIN	"B" MIN	"L"
5233748	2	10	9.500	1.250	4.750	2.000	2.000	5.000
5233750	3	8	13.000	1.750	6.500	3.125	2.500	6.813
5233751	3-1/2	5	15.000	2.000	7.563	3.250	3.250	7.875
5233776	4	20	16.000	2.063	8.000	3.375	3.250	8.375
5233753	5	30*	24.000	3.188	12.000	3.625	4.250	12.563
5233754	6	50*	30.000	4.000	15.000	3.750	5.00	15.688

\* Pallet Quantity

Dimensions are nominal

## Schedule 40 22-1/2° Elbow - Bell End

Conforms to UL651 and NEMA TC3

Material is Rigid PVC

Bend Tolerance is  $\pm 2^\circ$

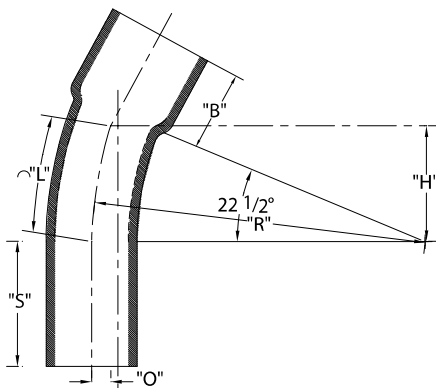

Part Number	Trade Size	Carton Qty.	"R"	"O"	"H"	"S" MIN	"B" MIN	"L"
5234097	3/4	25	4.500	.375	1.750	1.500	1.500	1.750
5236402	1	20	5.750	.313	2.188	1.875	1.500	2.250
5236403	1-1/4	25	7.250	.563	2.750	2.000	1.500	2.875
5234094	1-1/2	20	8.250	.625	3.125	2.000	2.000	3.250
5234067	2	10	9.500	.750	3.625	2.000	2.000	3.750
5234096	2-1/2	10	10.500	.813	4.000	3.000	2.250	4.125
5234068	3	8	13.000	1.000	5.000	3.125	2.500	5.125
5234095	3-1/2	5	15.000	1.125	5.750	3.250	3.250	5.875
5233867	4	20	16.000	1.250	6.125	3.375	3.250	6.250
5234037	5	60*	24.000	1.813	9.188	3.625	4.250	9.375
5233901	6	50*	30.000	2.250	11.500	3.750	5.000	11.750

\* Pallet Quantity

Dimensions are nominal