

Emergency Lighting Control For Switching Loads Universal Mount

Emergency Power Source and Method of Operation

- The emergency luminaire power is derived from a 24 hour central emergency power source. The local utility power company normally supplies the power through a UL1008 Transfer Switch or equal, but during a utility power failure, the transfer switch automatically switches to the emergency power source.
- The room switch turns on and off both regular and emergency luminaires simultaneously. This is accomplished by having the room switch leg power activate the **Emergency Power Control, ECS00-110**.
- Wire input #1 or #2 and neutral are connected internally to a sensing circuit. During a power interruption on the sensing input, this circuit causes contact X to drop into a N.C. position and turns on the emergency load(s). Review wiring diagram, on reverse, for details.



Automatic Diagnostic Feature

The unique feature of the ECS00-110 is the ability to place the unit above the accessible ceiling tile because the unit does not require an accessible test switch. Instead, when the room switch is turned off, the emergency luminaires stay on for 2.5 seconds and indicate that an emergency power source was available and that the ECS00-110, ballast, and lamp(s) are all functioning correctly.

This feature replaces a test switch and is approved for this purpose.



Initial Testing and Troubleshooting of ECS00-110

The unit is equipped with a green LED, which indicates if regular utility power is available and field sensing wiring is connected correctly.

ECS00-110 Universal Mount Wall or Ceiling Installation

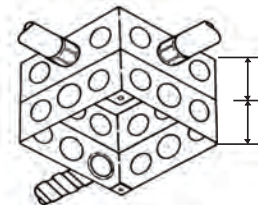

Recommended
Box Size 4-11/16
with blank cover

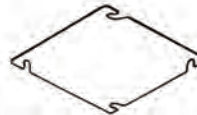
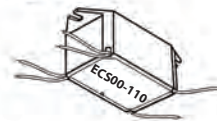

UL924 LISTED
EMERGENCY LIGHTING
EQUIPMENT
73PK

ECS00-110 can also be mounted in plenum, when tiles are removable.

ECS00-110 Universal Mount Fire Ceiling Installation

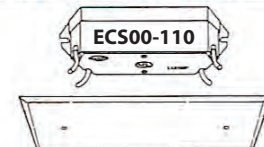
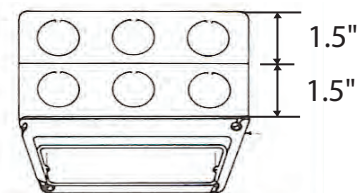

Model ECS00-110 Installation Instructions

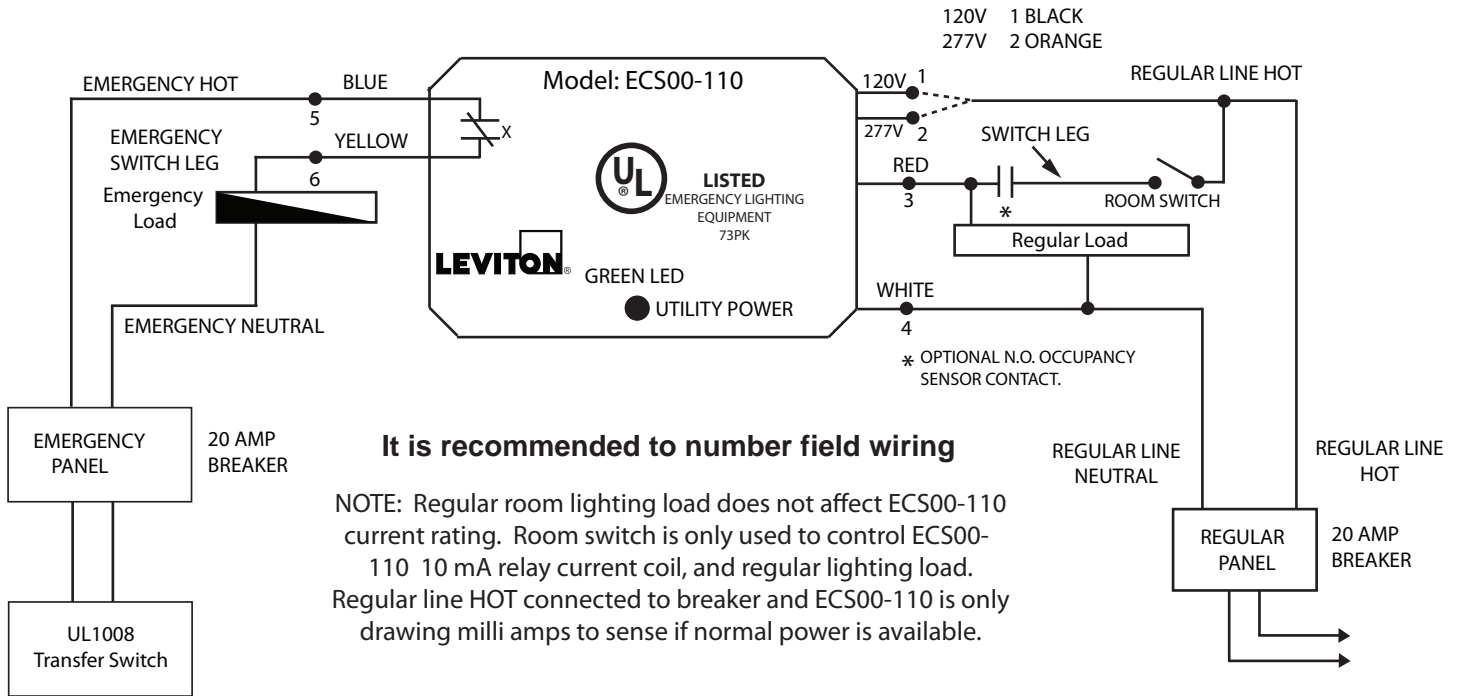

Installation

WARNING; TO AVOID FIRE, SHOCK, OR DEATH, TURN OFF POWER AT CIRCUIT BREAKER ON BOTH NORMAL POWER CIRCUIT, 24 HOUR NIGHT LIGHT/EMERGENCY GENERATOR CIRCUIT AND TEST THAT POWER IS OFF BEFORE WIRING.

In order to install the ECS00-110 in accordance with national/local code requirements, a qualified electrician should review and understand the installation instructions. Check voltage and current requirements. Install a self-adhesive 2" x 3" caution label in each fixture or load controlled by an ECS00-110 unit cautioning that this load is supplied from 2 different power sources, regular and emergency. Review wiring diagram and connect wires, one group at a time, in accordance with the numeric identification.

In order to provide a safe light level, when regular power is interrupted, it is recommended that a minimum of two 4' fluorescent tubes providing approximately 5000 lumen are controlled by a 24 hour emergency circuit and are spaced no farther than 24' in any direction from each other in a normal 9' white ceiling environment. The ECS00-110 is a universal type unit, convenient and fast to install virtually anywhere.

Electrical Specifications

Model ECS00-110
 Universal Mount-120/277
 120V or 277V Sensing Input
 120V or 277V Load
 10 Amp Load Rating
 N.C. Contact
 UL924 Listed

Mechanical Specifications

Mounts in 4-11/16" Junction Box
 with blank cover
 UL94V-0 Flame Rating
 Shipping Weight: 8 oz
 Temperature: 32°F - 140°F | Color : Black
 Size (with mounting ears):
 3-3/4"(L) x 1-3/4"(W) x 1-1/2"(H)

Troubleshooting & Maintenance of ECS00-110

If ECS00-110 does not function properly on startup perform the following tests:

- 1) To test normal operation, ensure branch circuit breaker is connected and utility power is available. If green LED is not illuminated, confirm wiring connections and continuity to branch panels.

- 2) To test emergency operation, ensure emergency source is connected and red LED is illuminated. Turn room switch to "OFF" position, and ensure that emergency lights stay illuminated for at least 2.5 seconds. If emergency lights do not stay on for at least 2.5 seconds, confirm wiring connections and perform testing on emergency panel and emergency power source.

No maintenance is required to keep the ECS00-110 functional. However, regular testing should be performed when the lamps or ballasts have been replaced or when facility remodeling has taken place.

Single Line Drawings

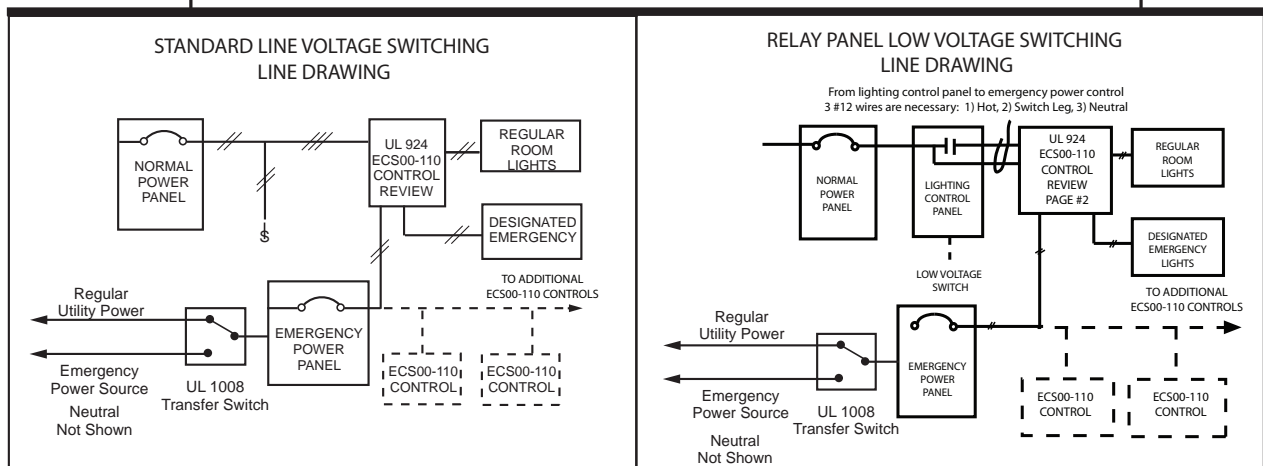
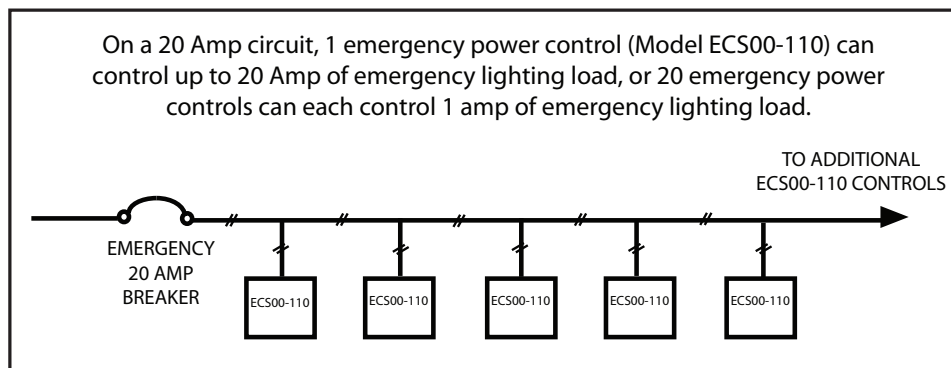

Common Wiring Scenarios

One Light Fixture in a room

For some installations which require only a single emergency light in an area with no regular lighting.

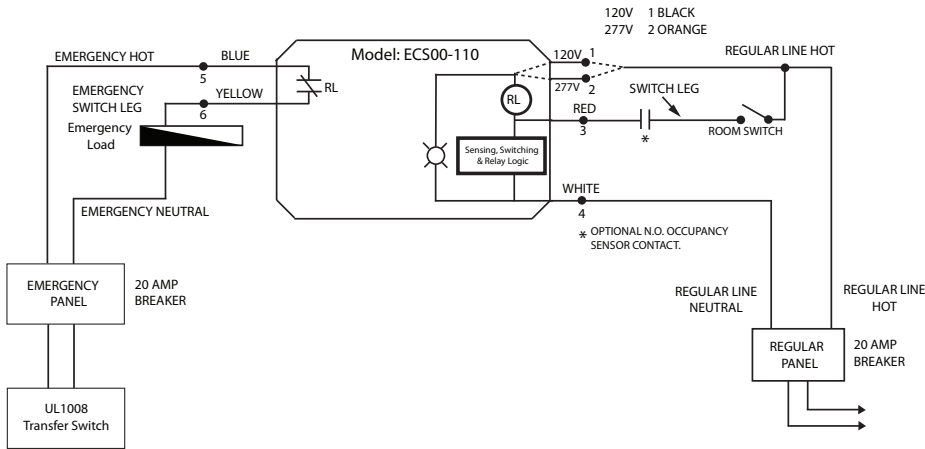

Dual Light Level Switching

For installations with dual light level controls. Can only be used when separate ballasts are used for A leg and B leg. If using modern bi-level ballasts, contact manufacturer for appropriate part number.

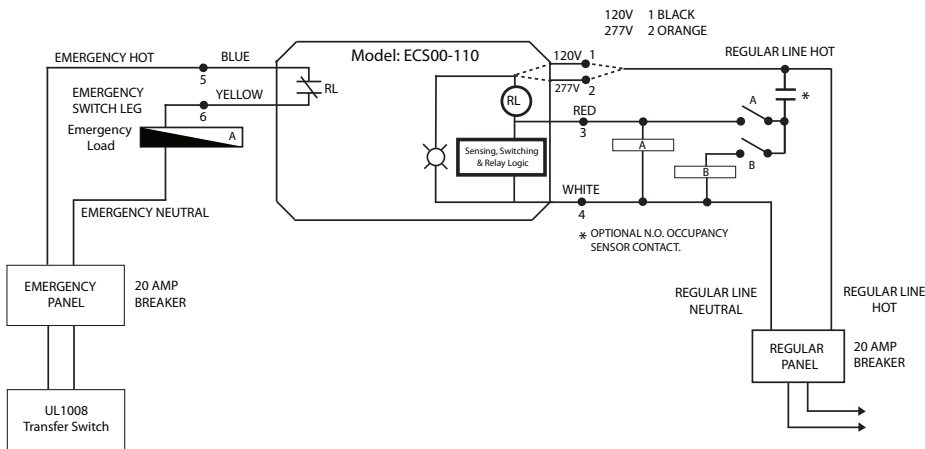

Wiring as shown will cause only "A" ballasts to operate as emergency fixtures. If all tubes are desired for emergency: use 2 ECS00-110's or contact the manufacturer.

Two 3-Way Switches

When using two 3 way switches in a room to control the lighting from two locations.

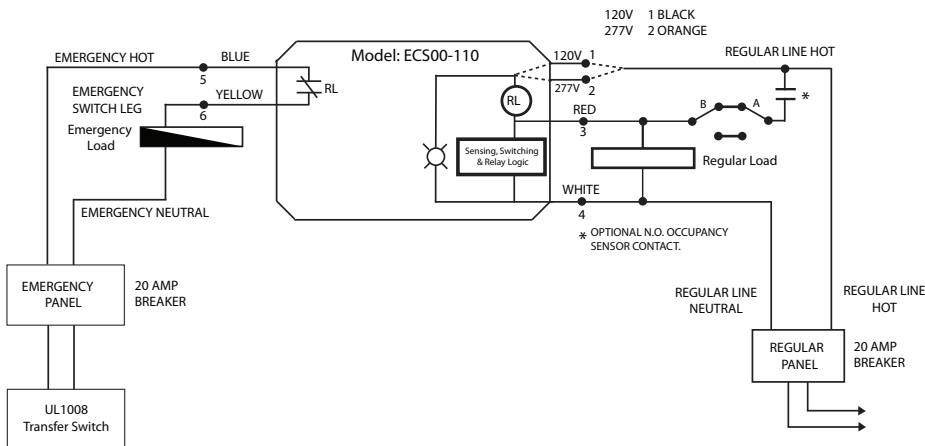

WARRANTY

Leviton Lighting & Energy Solutions of Leviton Manufacturing Co Inc warrants its Dimmer Systems and Controls to be free of material and workmanship defects for a period of five years after system acceptance or 62 months after shipment, whichever comes first. This Warranty is limited to repair or replacement of defective equipment returned Freight Pre-Paid to **Leviton Lighting & Energy Solutions at 20497 Teton Ave., Tualatin, Oregon 97062, USA. User shall call 1-800-959-6004** and request a return authorization number to mark on the outside of the returning carton, to assure that the returned material will be properly received at Leviton. All equipment shipped back to Leviton must be carefully and properly packed to avoid shipping damage. Replacement or repaired equipment will be returned to sender freight prepaid, F.O.B. factory. Leviton is not responsible for removing or replacing equipment on the job site, and will not honor charges for such work. Leviton will not be responsible for any loss of use time or subsequent damages should any of the equipment fail during the warranty period, but agrees only to repair or replace defective equipment returned to its plant in Tualatin, Oregon. This Warranty is void on any product that has been improperly installed, overloaded, short circuited, abused, or altered in any manner. **Neither the seller nor Leviton shall be liable for any injury, loss or damage, direct or consequential arising out of the use of or inability to use the equipment.** Leviton is not liable for incidental, indirect, special, or consequential damages, including, without limitation, damage to, or loss of use of, any equipment, lost sales or profits or delays or failure to perform this warranty obligation. This Warranty does not cover lamps, ballasts, and other equipment which is supplied or warranted directly to the user by their manufacturer. Leviton makes no warranty as to the Fitness for Purpose, merchantability or other implied Warranties.