

Start-up tool kits for new machines



Get your machine tooled up!

A new machine is a major investment, so a short payback time is always welcomed. To make it easy to get started with your new machine, we can provide you with a start-up tool kit that suits your operations.

We have made it very easy to choose the appropriate tools depending on what type of machining you will perform.

There are 66 different tools kits available for the most common turning centres, machining centres and sliding head machines. Each kit consists of typical tools plus inserts.

Make sure to get the most out of your machine investment. Your new machine will only start to make money for you when it's tooled up and running.



Table of content

Introduction.....	4
Turning centres	
Kit contents	5
External turning shank	6
External turning shank with high precision coolant	7
Internal boring bars	8
Drilling and internal turning	9
Internal boring bars with high precision coolant and EasyFix sleeves.....	10
Machining centres	
Kit contents	11
Milling cutters with adaptors for MAS-BT30	12
Milling cutters with adaptors for size 40 taper	13
Milling cutters for size 50 taper	14
CoroMill® 419 modular assembly for size 50 taper	15
Sliding head machines	
Kit contents	16
Citizen	
Internal turning – CoroTurn® XS	17
External turning – quick change with QS™ holding system	18
External turning – QS™ holding system, for quick change with high precision coolant	19
Star	
Internal turning – CoroTurn® XS	20
External turning – quick change with QS™ holding system.....	21
External turning – QS™ holding system, for quick change with high precision coolant	22
Tsugami	
Internal turning – CoroTurn® XS	23
External turning – quick change with QS™ holding system.....	24
External turning – QS™ holding system, for quick change with high precision coolant	25

Get your tool kit today!

Visit the tool kit web page to find your tool kit and ensure that your machine gets up and running right away. Here you will find more information about the kits and support for optimising your machining.

www.sandvik.coromant.com/startuptoolkits

Introduction

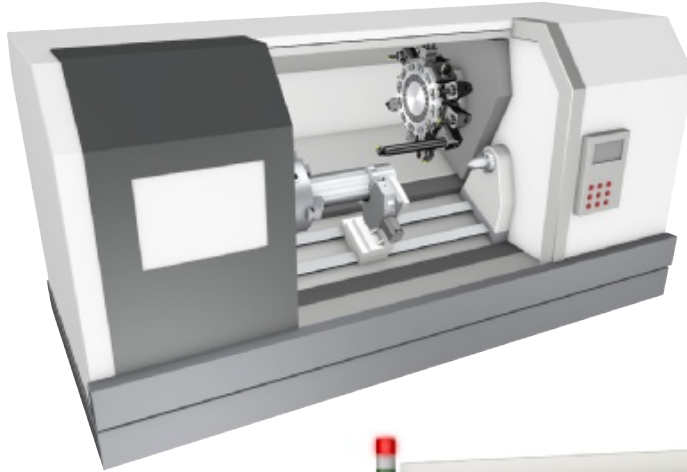

Turning centres

There are 28 different tool kits available for turning centres, depending on machine interface size, metric or imperial standard and operation (external or internal). Each holder comes with four inserts. You can also choose tools with high precision coolant technology to get the most out of your turning operations.

Machining centres

You can choose between ten different tool kits, depending on machine interface and metric or imperial standard. Kits for taper size 30 and 40 include the new modular system Coromant EH for smaller diameter milling assemblies. By reducing the assembly gauge length Coromant EH provides significant productivity in small and medium sized machining centres.



Sliding head machines

There are 28 different kits to choose from, depending on machine type, size, and whether you require tools for an external or internal operation. Choose high precision coolant technology for improved performance and chip control.



Did you know ...

By adding a tool kit to your new machine, you can cut the payback time significantly by getting started right away!

Turning centres

T-Max® P and CoroTurn® 107

With CoroTurn HP high precision nozzles in the tool holders, T-Max® P and CoroTurn 107 promise good chip control, process security and high productivity due to jets perfectly directed at the cutting zone. In combination with dedicated insert geometries for high precision coolant, the performance in terms of tool life can be increased.

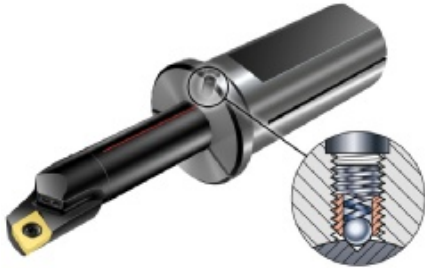
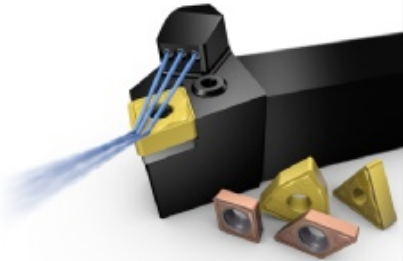

EasyFix

EasyFix sleeves are easy to use and reduce set-up time substantially. It is an outstanding solution for cylindrical boring bars. A spring plunger mounted in the sleeve clicks into a groove in the bar to guarantee the correct centres height. The slot in the cylindrical sleeve is metallic sealed which allows the existing coolant supply system to be used.

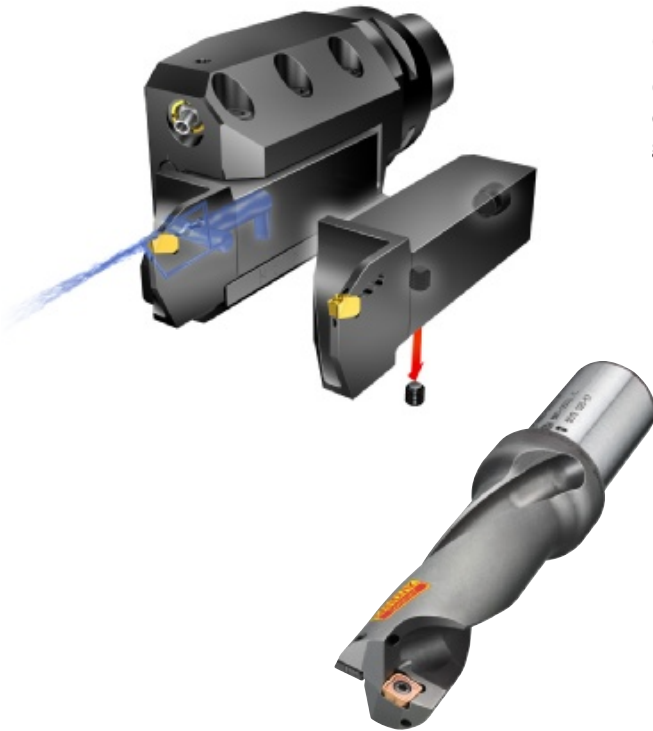

CoroCut®

CoroCut is a complete and flexible machining program of cutting tools, holders, grades and geometries for parting and grooving.

CoroDrill® 880

An indexable drill designed with a strong drill body with centres and periphery insert unique Step Technology™ for perfect cutting force balance. CoroDrill 880 gives high performance in all work-piece materials.

KIT	TC	M	R	E	25	HP
1	2	3	4	5	6	7
1	KIT - start-up kit					
2	Machine type TC - Turning centres MC - Machining centres QS - External turning for sliding head machines CXS - Internal machining for sliding head machines					
3	Unit M - Metric A - Imperial					
4	Hand of tooling R - right hand L - left hand					
5	Operation E - External I - Internal					
6	Machine interface 20 - 20 mm 25 - 25 mm 40 - 40 mm 0750 - 0.75 inch 1000 - 1.0 inch 1250 - 1.25 inch					
7	HP - CoroTurn® HP high precision coolant					

Turning centres

External turning shank

Included products

	Qty
T-Max® P holder for CNMG insert	1
T-Max® P holder for DNMG insert	1
Holder for CoroCut® 1-2 parting off insert	1
Negative C-style (CNMG) insert for T-Max® P	4
Negative D-style (DNMG) insert for T-Max® P	4
3 mm insert for CoroCut® 1-2	4



Right hand shown.

Metric

Ordering code	Shank size, mm	Hand	Holder	Qty	Insert	Qty
KIT-TC-M-LE-20	20 × 20	Left	DCLNL 2020K 12	1	CNMG 120408-XM GC30	4
			DDJNL 2020K 11	1	DNMX 110404-WF 4325	4
			LF123G20-2020B	1	N123G2-0300-0003-TF 1125	4
KIT-TC-M-LE-25	25 × 25	Left	DCLNL 2525M 12	1	CNMG 120408-XM GC30	4
			DDJNL 2525M 15	1	DNMG 150608-XF GC30	4
			LF123G20-2525B	1	N123G2-0300-0003-TF 1125	4
KIT-TC-M-RE-20	20 × 20	Right	DCLNR 2020K 12	1	CNMG 120408-XM GC30	4
			DDJNR 2020K 11	1	DNMX 110404-WF 4325	4
			RF123G20-2020B	1	N123G2-0300-0003-TF 1125	4
KIT-TC-M-RE-25	25 × 25	Right	DCLNR 2525M 12	1	CNMG 120408-XM GC30	4
			DDJNR 2525M 15	1	DNMG 150608-XF GC30	4
			RF123G20-2525B	1	N123G2-0300-0003-TF 1125	4

Imperial

Ordering code	Shank size, inch	Hand	Holder	Qty	Insert	Qty
KIT-TC-A-LE-0750	0.75 × 0.75	Left	DCLNL 12 4B	1	CNMG 432-XM GC30	4
			DDJNL 12 4B	1	DNMG 432-XF GC30	4
			LF123G079-12B	1	N123G2-0300-0003-TF 1125	4
KIT-TC-A-LE-1000	1.0 × 1.0	Left	DCLNL 16 4C	1	CNMG 432-XM GC30	4
			DDJNL 16 4C	1	DNMG 432-XF GC30	4
			LF123G079-16B	1	N123G2-0300-0003-TF 1125	4
KIT-TC-A-RE-0750	0.75 × 0.75	Right	DCLNR 12 4B	1	CNMG 432-XM GC30	4
			DDJNR 12 4B	1	DNMG 432-XF GC30	4
			RF123G079-12B	1	N123G2-0300-0003-TF 1125	4
KIT-TC-A-RE-1000	1.0 × 1.0	Right	DCLNR 16 4C	1	CNMG 432-XM GC30	4
			DDJNR 16 4C	1	DNMG 432-XF GC30	4
			RF123G079-16B	1	N123G2-0300-0003-TF 1125	4

Turning centres

External turning shank with high precision coolant

Included products	Qty
T-Max® P holder with high precision coolant for CNMG insert	1
T-Max® P holder with high precision coolant for DNMG insert	1
Negative C-style (CNMG) insert for T-Max® P	4
Negative D-style (DNMG) insert for T-Max® P	4
Hose for coolant connection	2
Connection kit	2
Coolant feed plug	2
Coolant blanking plug	2

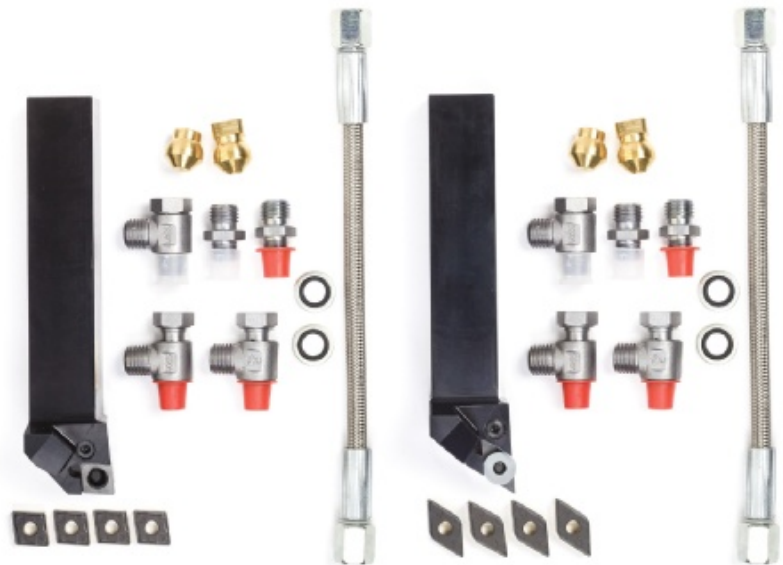

Right hand shown.

Metric

Ordering code	Shank size, mm	Hand	Holder	Qty	Insert	Qty	Coolant connectors	Qty
KIT-TC-M-LE-20HP	20 × 20	Left	PCLNL 2020K 12HP	1	CNMG 120408-PMC 4325	4	5692 070-01	2
			PDJNL 2020K 15HP	1	DNMG 150608-PMC 4325	4	5693 065-01	2
							5692 063-01	2
							5692 063-02	2
KIT-TC-M-LE-25HP	25 × 25	Left	PCLNL 2525M 12HP	1	CNMG 120408-PMC 4325	4	5692 070-01	2
			PDJNL 2525M 15HP	1	DNMG 150608-PMC 4325	4	5693 065-01	2
							5692 063-01	2
							5692 063-02	2
KIT-TC-M-RE-20HP	20 × 20	Right	PCLNR 2020K 12HP	1	CNMG 120408-PMC 4325	4	5692 070-01	2
			PDJNR 2020K 15HP	1	DNMG 150608-PMC 4325	4	5693 065-01	2
							5692 063-01	2
							5692 063-02	2
KIT-TC-M-RE-25HP	25 × 25	Right	PCLNR 2525M 12HP	1	CNMG 120408-PMC 4325	4	5692 070-01	2
			PDJNR 2525M 15HP	1	DNMG 150608-PMC 4325	4	5693 065-01	2
							5692 063-01	2
							5692 063-02	2

Imperial

Ordering code	Shank size, inch	Hand	Holder	Qty	Insert	Qty	Coolant connectors	Qty
KIT-TC-A-LE-0750HP	0.75 × 0.75	Left	PCLNL 12 4BHP	1	CNMG 432-PMC 4325	4	5692 070-01	2
			PDJNL 12 4BHP	1	DNMG 432-PMC 4325	4	5693 065-01	2
							5692 063-01	2
							5692 063-02	2
KIT-TC-A-LE-1000HP	1.0 × 1.0	Left	PCLNL 16 4DHP	1	CNMG 432-PMC 4325	4	5692 070-01	2
			PDJNL 16 4DHP	1	DNMG 432-PMC 4325	4	5693 065-01	2
							5692 063-01	2
							5692 063-02	2
KIT-TC-A-RE-0750HP	0.75 × 0.75	Right	PCLNR 12 4BHP	1	CNMG 432-PMC 4325	4	5692 070-01	2
			PDJNR 12 4BHP	1	DNMG 432-PMC 4325	4	5693 065-01	2
							5692 063-01	2
							5692 063-02	2
KIT-TC-A-RE-1000HP	1.0 × 1.0	Right	PCLNR 16 4DHP	1	CNMG 432-PMC 4325	4	5692 070-01	2
			PDJNR 16 4DHP	1	DNMG 432-PMC 4325	4	5693 065-01	2
							5692 063-01	2
							5692 063-02	2

Turning centres

Internal boring bars

Included products

Qty

Boring bar (Ø25 mm or 1 inch) for CNMG insert	1
Boring bar (Ø20 mm or 0.75 inch) for DCMT insert	1
Boring bar (Ø20 mm or 0.75 inch) for CCMT insert	1
Negative C-style (CNMG) insert for T-Max® P holder	4
Positive D-style (DCMT) insert for CoroTurn® 107 holder	4
Positive C-style (CCMT) insert for CoroTurn® 107 holder	4



Right hand shown.

Metric

Ordering code	Hand	Shank size, mm	Holder	Qty	Insert	Qty
KIT-TC-M-LI	Left	25	A25T-PCLNL 12	1	CNMG 120408-XM GC30	4
		20	A20S-SDUCL 11	1	DCMT 11T308-XM GC30	4
		20	A20S-SCLCL 09	1	CCMT 09T304-XM GC30	4
KIT-TC-M-RI	Right	25	A25T-PCLNR 12	1	CNMG 120408-XM GC30	4
		20	A20S-SDUCR 11	1	DCMT 11T308-XM GC30	4
		20	A20S-SCLCR 09	1	CCMT 09T304-XM GC30	4

Imperial

Ordering code	Hand	Shank size, inch	Holder	Qty	Insert	Qty
KIT-TC-A-LI	Left	1.0	A16T-DCLNL 4	1	CNMG 432-XM GC30	4
		0.75	A12S-SDUCL 3	1	DCMT 3(2.5)2-XM GC30	4
		0.75	A12S-SCLCL 3	1	CCMT 3(2.5)1-XM GC30	4
KIT-TC-A-RI	Right	1.0	A16T-DCLNR 4	1	CNMG 432-XM GC30	4
		0.75	A12S-SDUCR 3	1	DCMT 3(2.5)2-XM GC30	4
		0.75	A12S-SCLCR 3	1	CCMT 3(2.5)1-XM GC30	4

Turning centres

Drilling and internal turning

Included products

Qty

Indexable drill – CoroDrill® 880 (Ø27 mm or 1.062 inch)	1
Drilling insert – periphery	4
Drilling insert – centres	4
Boring bar (Ø20 mm or 0.75 inch) for DCMT insert	1
Boring bar (Ø20 mm or 0.75 inch) for CCMT insert	1
Positive D-style (DCMT) insert for CoroTurn® 107 holder	4
Positive C-style (CCMT) insert for CoroTurn® 107 holder	4



Right hand shown.

Metric

Ordering code	Hand	Shank size, mm	Holder	Qty	Insert	Qty
KIT-TC-M-LI-32	Left	20	A20S-SCLCL 09	1	CCMT 09T308-XM GC30	4
		20	A20S-SDUCL 11	1	DCMT 11T308-XM GC30	4
		32	880-D2700L32-03	1	880-05 03 05H-C-LM 1044	4
					880-05 03 W08H-P-LM 4044	4
KIT-TC-M-RI-32	Right	20	A20S-SCLCR 09	1	CCMT 09T308-XM GC30	4
		20	A20S-SDUCR 11	1	DCMT 11T308-XM GC30	4
		32	880-D2700L32-03	1	880-05 03 05H-C-LM 1044	4
					880-05 03 W08H-P-LM 4044	4

Imperial

Ordering code	Hand	Shank size, inch	Holder	Qty	Insert	Qty
KIT-TC-A-LI-1250	Left	0.75	A20T-SCLCL 4	1	CCMT 432-PM 4325	4
		0.75	A20T-SDUCL 3	1	DCMT 3(2.5)2-XM GC30	4
		1.25	A880-D1062LX31-03	1	880-05 03 05H-C-LM 1044	4
					880-05 03 W08H-P-LM 4044	4
KIT-TC-A-RI-1250	Right	0.75	A20T-SCLCR 4	1	CCMT 432-PM 4325	4
		0.75	A20T-SDUCR 3	1	DCMT 3(2.5)2-XM GC30	4
		1.25	A880-D1062LX31-03	1	880-05 03 05H-C-LM 1044	4
					880-05 03 W08H-P-LM 4044	4

Turning centres

Internal boring bars with high precision coolant and EasyFix sleeves

Included products

Qty

EasyFix sleeve – OD 40 mm to ID 25 mm or OD 1.5 inch to ID 1.0 inch	1
EasyFix sleeve – OD 40 mm to ID 20 mm or OD 1.5 inch to ID 0.75 inch	2
Boring bar (∅25 mm or 1.0 inch) for DCMT insert	1
Boring bar (∅20 mm or 0.75 inch) for DCMT insert	1
Boring bar (∅20 mm or 0.75 inch) for CCMT insert	1
Positive D-style (DCMT) insert for CoroTurn® 107 holder	6
Positive C-style (CCMT) insert for CoroTurn® 107 holder	4



Right hand shown.

Metric

Ordering code	Hand	Shank size, mm	Holder	Qty	Insert	Qty	EasyFix sleeve	Qty
KIT-TC-M-LI-40EF	Left	25	A25T-SDUCL 11HP-R	1	DCMT 11T308-XM GC30	6	EF-40-25	1
		20	A20S-SDUCL 11HP-R	1	CCMT 09T304-XM GC30	4	EF-40-20	2
		20	A20S-SCLCL 09HP-R	1				
KIT-TC-M-RI-40EF	Right	25	A25T-SDUCR 11HP-R	1	DCMT 11T308-XM GC30	6	EF-40-25	1
		20	A20S-SDUCR 11HP-R	1	CCMT 09T304-XM GC30	4	EF-40-20	2
		20	A20S-SCLCR 09HP-R	1				

Imperial

Ordering code	Hand	Shank size, inch	Holder	Qty	Insert	Qty	EasyFix sleeve	Qty
KIT-TC-A-LI-1500EF	Left	1.0	A16T-SDUCL 3HP-R	1	DCMT 3(2.5)2-XM GC30	6	EF-A24-A16	1
		0.75	A12S-SDUCL 3HP-R	1	CCMT 3(2.5)1-XM GC30	4	EF-A24-A12	2
		0.75	A12S-SCLCL 3HP-R	1				
KIT-TC-A-RI-1500EF	Right	1.0	A16T-SDUCR 3HP-R	1	DCMT 3(2.5)2-XM GC30	6	EF-A24-A16	1
		0.75	A12S-SDUCR 3HP-R	1	CCMT 3(2.5)1-XM GC30	4	EF-A24-A12	2
		0.75	A12S-SCLCR 3HP-R	1				

Machining centres

Coromant EH

Coromant EH is a modular system with exchangeable heads. The modular design delivers great advantages in large machining centres requiring long reach, but also in small to medium-sized machining centres when there is a critical gauge length before vibration tendency starts to reduce cutting parameters.

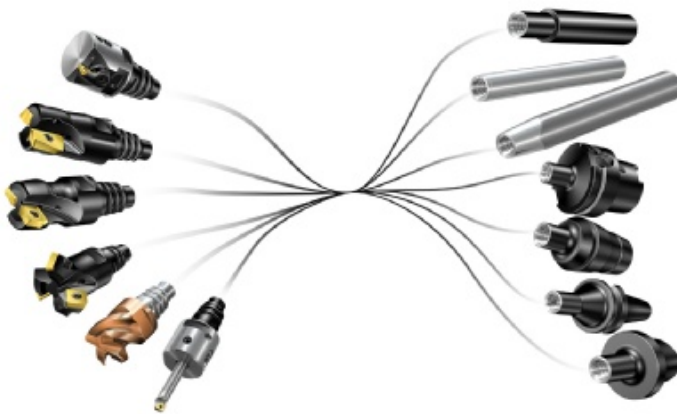

KIT	MC	M	B	50	C5	419
1	2	3	4	5	6	7
1	KIT - start-up kit					
2	Machine type TC - Turning centres MC - Machining centres QS - External turning for sliding head machines CXS - Internal machining for sliding head machines					
3	Unit M - Metric A - Imperial					
4	Machine interface B - MAS-BT I - ISO/DIN V - CAT-V SK - suitable for all interface types					
5	Spindle size 30 40 50					
6	Modular interface C5 - 50 mm					
7	Milling concept 419 - CoroMill® 419					

CoroMill® 316



CoroMill 316 is a flexible exchangeable head milling system that can be applied in a wide variety of operations, such as high feed face milling, slot milling, helical interpolation, shoulder milling, profile milling and chamfer milling. It is easy to use and handle and the head can be changed in a few seconds. This results in short machine stoppages when switching between various operations.

CoroMill® 390



The CoroMill 390 family is a large, versatile programme for many applications. It generates a good quality 90-degree shoulder and is ideal for ramping and helical interpolation.

CoroMill® 245



CoroMill 245 is excellent if you need high metal removal rate and a mirror finish. The light cutting action provides low cutting forces and low power consumption. It is designed with enhanced corners to reduce burr formation and frittering of the component.

CoroMill® 345



CoroMill 345 is a cost-efficient face mill for high productivity in terms of feed per tooth and metal removal rate. The robust cutter body and shim-protected tip seats give security to the machining process. Internal coolant on all cutters up to diameter 125 mm (5 inch).

Machining centres

Milling cutters with adaptors for MAS-BT30

Included products (metric)	Qty
Adaptor – BT30 to Coromant EH20	1
Adaptor – BT30 to Coromant EH12	1
Arbor adaptor for face mill – 16 mm arbor	1
CoroMill® 390 end mill with EH20 coupling – Ø20 mm	1
CoroMill® 316 end mill with EH12 coupling – Ø12 mm	1
CoroMill® 316 chamfer cutter with EH12 coupling	1
90° face mill – CoroMill® 390 Ø40 mm	1
Size 11 insert for CoroMill® 390	6

Included products (imperial)	Qty
Adaptor – BT30 to Coromant EH25	1
Adaptor – BT30 to Coromant EH12	1
Arbor adaptor for face mill – 0.75 inch arbor	1
CoroMill® 390 end mill with EH25 coupling – Ø1.0 inch	1
CoroMill® 316 end mill with EH12 coupling – Ø0.5 inch	1
CoroMill® 316 chamfer cutter with EH12 coupling	1
90° face mill – CoroMill® 390 Ø1.5 inch	1
Size 11 insert for CoroMill® 390	7



Metric kit shown.

Metric

Ordering code	Adaptor	Qty	Cutter body	Qty	Insert	Qty	CoroMill® 316 head	Qty
KIT-MC-M-B30	A205-30 16 035	1	R390-040Q16-11M	1	R390-11T308M-PL 1030	6	316-12SM450C12010P 1030	1
	392.55EH-30 20 049	1	R390-020EH20-11L	1			316-12CM600-12045G 1030	1
	392.55EH-30 12 063	1						

Imperial

Ordering code	Adaptor	Qty	Cutter body	Qty	Insert	Qty	CoroMill® 316 head	Qty
KIT-MC-A-B30	AA205-30 19 030	1	RA390-038R19-11M	1	R390-11T308M-PL 1030	7	A316-12SM450C05008P 1030	1
	392.55EH-30 25 054	1	RA390-025EH25-11M	1			316-12CM600-12045G 1030	1
	392.55EH-30 12 063	1						

Machining centres

Milling cutters with adaptors for size 40 taper

Included products (metric)	Qty
Adaptor to Coromant EH16	1
Arbor adaptor for face mill – 16 mm arbor	1
Arbor adaptor for face mill – 22 mm arbor	1
CoroMill® 390 end mill with EH16 coupling – Ø16 mm	1
90° shoulder mill – CoroMill® 390 Ø40 mm	1
45° face mill – CoroMill® 245 Ø63 mm	1
Size 11 insert for CoroMill® 390	6
Size 12 insert for CoroMill® 245	5

Included products (imperial)	Qty
Adaptor to Coromant EH16	1
Arbor adaptor for face mill – 0.75 inch arbor	2
CoroMill® 390 end mill with EH16 coupling – Ø0.575 inch	1
90° shoulder mill – CoroMill® 390 Ø1.5 inch	1
45° face mill – CoroMill® 245 Ø2.5 inch	1
Size 11 insert for CoroMill® 390	6
Size 12 insert for CoroMill® 245	5



Metric kit shown.

Metric

Ordering code	Interface	Adaptor	Qty	Cutter body	Qty	Insert	Qty
KIT-MC-MB40	MAS-BT 40	392.55EH-40 16 060	1	R390-016EH16-11L	1	R390-11T308M-PL 1030	6
		A2B05-40 16 035	1	R390-040Q16-11M	1	R245-12T3M-PM 1030	5
		A2B05-40 22 035	1	R245-063Q22-12M	1		
KIT-MC-MI40	ISO 40	392.140EH-40 16 049	1	R390-016EH16-11L	1	R390-11T308M-PL 1030	6
		A1B05-40 16 035	1	R390-040Q16-11M	1	R245-12T3M-PM 1030	5
		A1B05-40 22 035	1	R245-063Q22-12M	1		

Imperial

Ordering code	Interface	Adaptor	Qty	Cutter body	Qty	Insert	Qty
KIT-MC-AV40	CAT-V 40	A392.45EH-40 16 065	1	RA390-016EH16-11L	1	R390-11T308M-PL 1030	6
		AA3B05-40 19 038	2	RA390-038R19-11M	1	R245-12T3M-PM 1030	5
				RA245-063R19-12M	1		

Machining centres

Milling cutters for size 50 taper

Included products (metric)	Qty
High feed cutter – CoroMill® 419 Ø50 mm	1
90° shoulder mill – CoroMill® 390 Ø50 mm	1
45° face mill – CoroMill® 245 Ø80 mm	1
Size 14 for CoroMill® 419	4
Size 17 for CoroMill® 390	4
Size 12 for CoroMill® 245	6

Included products (imperial)	Qty
High feed cutter – CoroMill® 419 Ø2 inch	1
90° shoulder mill – CoroMill® 390 Ø2 inch	1
45° face mill – CoroMill® 345 Ø4 inch	1
Size 14 insert for CoroMill® 419	4
Size 17 insert for CoroMill® 390	4
Size 13 insert for CoroMill® 345	7



Metric kit shown.

Metric

Ordering code	Cutter body	Qty	Insert	Qty
KIT-MC-M-SK50	419-050Q22-14M	1	419R-1405M-PM 1030	4
	R390-050Q22-17M	1	R390-170408M-PM 1030	4
	R245-080Q27-12M	1	R245-12T3M-PM 1030	6

Imperial

Ordering code	Cutter body	Qty	Insert	Qty
KIT-MC-A-SK50	A419-051R19-14M	1	419R-1405M-PM 1030	4
	RA390-051R19-17M	1	R390-170408M-PM 1030	4
	A345-102R38-13M	1	345R-1305M-PM 1030	7

Machining centres

CoroMill® 419 modular assembly for size 50 taper

Included products	Qty
Machine interface adaptor to C5	1
Extension adaptor – C5 to C5	1
High feed cutter – CoroMill® 419 Ø54 mm	1
Size 14 insert for CoroMill® 419	4
Assembly key	1



Metric

Ordering code	Interface	Adaptor	Qty	Cutter body	Qty	Insert	Qty
KIT-MC-MB50-C5-419	MAS BT 50	C5-390.58-50 040	1	419-052C5-14M	1	419R-1405M-PM 1030	4
		C5-391.01-50 080A	1		1		
		5680 015-01	1		1		
KIT-MC-MI50-C5-419	ISO 50	C5-390.140-50 030	1	419-052C5-14M	1	419R-1405M-PM 1030	4
		C5-391.01-50 080A	1		1		
		5680 015-01	1		1		

Imperial

Ordering code	Interface	Adaptor	Qty	Cutter body	Qty	Insert	Qty
KIT-MC-MV50-C5-419	CAT-V 50	C5-A390.45-50 040	1	419-052C5-14M	1	419R-1405M-PM 1030	4
		C5-391.01-50 080A	1		1		
		5680 015-01	1		1		

Sliding head machines

Quick change with QS™ holding system

QS holding system maximizes active production time as the tools can easily be removed from the machine for insert indexing. This enables you to start running directly without the need for setting and measuring. Consider CoroTurn® HP (high precision coolant) for problem-free production and improved component quality in the most demanding, long-chipping materials. The original tool clamping is simply replaced by the machine specific wedges in a matter of minutes.



KIT	QS	M	CZ	12	HP
1	2	3	4	5	6
1	KIT - start-up kit				
2	Machine type TC - Turning centres MC - Machining centres QS - External turning for sliding head machines CXS - Internal machining for sliding head machines				
3	Unit M - Metric A - Imperial				
4	Machine tool builder CZ - Citizen ST - Star TG - Tsugami				
5	Machine interface - QS shank 12 - 12 mm 16 - 16 mm 0500 - 0.5 inch 0625 - 0.625 inch				
	Machine interface - CXS internal 22 - 22 mm 25 - 25 mm 0750 - 0.75 inch (19.05 mm) 1000 - 1.0 inch (25.4 mm)				
6	HP - CoroTurn® HP high precision coolant technology				

CoroTurn® XS

For internal machining, CoroTurn XS allows quick changing and setting of boring bars. The insert locates precisely into the boring bar adaptor with a locating pin which positions the insert into the correct position – centres line and length.

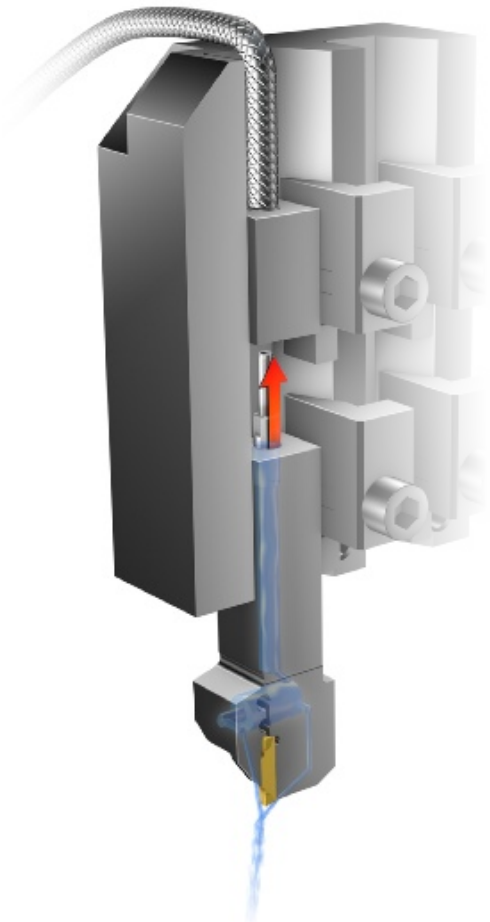

Sliding head machines – Citizen

Internal turning – CoroTurn® XS

Included products	Qty
Holder for CoroTurn® XS size 4 insert	1
Boring insert for CoroTurn® XS, GC1025	4
Threading insert for CoroTurn® XS, GC1025	2
Grooving insert for CoroTurn® XS, GC1025	2



Ordering code	Shank size, mm (inch)	Holder	Qty	Insert	Qty
KIT-CXS-A-CZ-0750	19.05 (0.75)	CXS-A0750-04	1	CXS-04T098A15-4210R 1025	4
				CXS-04G100-4215R 1025	2
				CXS-04TH050VM-4215R 1025	2
KIT-CXS-A-CZ-1000	25.4 (1.0)	CXS-A1000-04M	1	CXS-04T098A15-4210R 1025	4
				CXS-04G100-4215R 1025	2
				CXS-04TH050VM-4215R 1025	2

Sliding head machines – Citizen

External turning – quick change with QS™ holding system

Included products	Qty
QS holder for positive V-style insert (VCEX)	1
QS holder for positive D-style insert (DCGT)	1
QS holder for CoroCut® 1-2 parting off insert	1
QS holder for positive C-style insert (CCGT)	1
Positive V-style insert (VCEX), GC1105	4
Positive D-style insert (DCGT), GC1105	4
2 mm insert for CoroCut 1-2, GC1125	4
Positive C-style insert (CCGT), GC1105	4
QS stop	4
QS wedge	8



Metric

Ordering code	Shank size, mm	Holder	Qty	Insert	Qty	Wedge/stop	Qty
KIT-QS-M-CZ-12	12 × 12	QS-SVJBR 1212E11-B1	1	VCEX 110301R-F 1105	4	QS-1212	4
		QS-SDJCR 1212E07	1	DCGT 070204-UM 1105	4	QS-30	8
		QS-SCLCR 1212E09	1	CCGT 09T304-UM 1105	4		
		QS-LF123E11-1212B	1	N123E2-0200-0002-CM 1125	4		
KIT-QS-M-CZ-16	16 × 16	QS-SVJBR 1616E11-B1	1	VCEX 110301R-F 1105	4	QS-1616	4
		QS-SDJCR 1616E11	1	DCGT 11T304-UM 1105	4	QS-40	8
		QS-SCLCR 1616E09	1	CCGT 09T304-UM 1105	4		
		QS-LF123E11-1616B	1	N123E2-0200-0002-CM 1125	4		

Imperial

Ordering code	Shank size, inch	Holder	Qty	Insert	Qty	Wedge/stop	Qty
KIT-QS-A-CZ-0500	0.5 × 0.5	QS-SVJBR 082X-B1	1	VCEX 110301R-F 1105	4	QS-A08	4
		QS-SDJCR 083X	1	DCGT 11T304-UM 1105	4	QS-30A	8
		QS-SCLCR 083X	1	CCGT 09T304-UM 1105	4		
		QS-LF123E043-08B	1	N123E2-0200-0002-CM 1125	4		
KIT-QS-A-CZ-0625	0.625 × 0.625	QS-SVJBR 102X-B1	1	VCEX 110301R-F 1105	4	QS-A10	4
		QS-SDJCR 103X	1	DCGT 11T304-UM 1105	4	QS-40A	8
		QS-SCLCR 103X	1	CCGT 09T304-UM 1105	4		
		QS-LF123E043-10B	1	N123E2-0200-0002-CM 1125	4		

Sliding head machines – Citizen

External turning – QS™ holding system for quick change with high precision coolant

Included products	Qty
QS holder for positive V-style insert (VCEX)	1
QS holder for positive D-style insert (DCGT)	1
QS holder for CoroCut® QD parting off insert	1
QS holder for positive C-style insert (CCGT)	1
QS holder for CoroThread® 266 threading insert	1
Positive V-style insert (VCEX), GC1105	4
Positive D-style insert (DCGT), GC1105	4
2 mm parting insert for CoroCut® QD, GC1125	4
Positive C-style insert (CCGT), GC1105	4
Threading insert for CoroThread® 266 holder, GC1135	4
QS stop	5
QS wedge	10
Coolant connector	5



Metric

Ordering code	Shank size, mm	Holder	Qty	Insert	Qty	Wedge/stop	Qty
KIT-QS-M-CZ-12HP	12 × 12	QS-SVJCR 1212E11HP	1	VCEX 110301R-F 1105	4	QS-1212HP-M	5
		QS-SDJCR 1212E07HP	1	DCGT 070204-UM 1105	4	QS-30	10
		QS-SCLCR 1212E09HP	1	CCGT 09T304-UM 1105	4	5696 001-01	5
		QS-QD-LFE16C1212S	1	QD-NE-0200-0002-CM 1125	4		
KIT-QS-M-CZ-16HP	16 × 16	QS-SVJCR 1616E11HP	1	VCEX 110301R-F 1105	4	QS-1616HP-M	5
		QS-SDJCR 1616E11HP	1	DCGT 11T304-UM 1105	4	QS-40	10
		QS-SCLCR 1616E09HP	1	CCGT 09T304-UM 1105	4	5696 001-01	5
		QS-QD-LFE20C1616S	1	QD-NE-0200-0002-CM 1125	4		
		QS-266RFA-1616-16HP	1	266RG-16MM01A150M 1135	4		

Imperial

Ordering code	Shank size, inch	Holder	Qty	Insert	Qty	Wedge/stop	Qty
KIT-QS-A-CZ-0500HP	0.5 × 0.5	QS-SVJCR 082XHP	1	VCEX 110301R-F 1105	4	QS-A08HP-M	5
		QS-SDJCR 082XHP	1	DCGT 070204-UM 1105	4	QS-30A	10
		QS-SCLCR 083XHP	1	CCGT 09T304-UM 1105	4	5696 001-01	5
		QS-QD-LFE0625C08S	1	QD-NE-0200-0002-CM 1125	4		
		QS-266RFA-083HP	1	266RG-16UN01A180M 1135	4		
KIT-QS-A-CZ-0625HP	0.625 × 0.625	QS-SVJCR 102XHP	1	VCEX 110301R-F 1105	4	QS-A10HP-M	5
		QS-SDJCR 103XHP	1	DCGT 11T304-UM 1105	4	QS-40A	10
		QS-SCLCR 103XHP	1	CCGT 09T304-UM 1105	4	5696 001-01	5
		QS-QD-LFE0800C10S	1	QD-NE-0200-0002-CM 1125	4		
		QS-266RFA-103HP	1	266RG-16UN01A180M 1135	4		

Sliding head machines – Star

Internal turning – CoroTurn® XS

Included products	Qty
Holder for CoroTurn® XS size 4 insert	1
Boring insert for CoroTurn® XS, GC1025	4
Threading insert for CoroTurn® XS, GC1025	2
Grooving insert for CoroTurn® XS, GC1025	2



Ordering code	Shank size, mm	Holder	Qty	Insert	Qty
KIT-CXS-M-ST-22	22	CXS-A22-04	1	CXS-04T098A15-4210R 1025	4
				CXS-04G100-4215R 1025	2
				CXS-04TH050VM-4215R 1025	2

Sliding head machines – Star

External turning – quick change with QS™ holding system

Included products	Qty
QS holder for positive V-style insert (VCEX)	1
QS holder for positive D-style insert (DCGT)	1
QS holder for CoroCut® 1-2 parting off insert	1
QS holder for positive C-style insert (CCGT)	1
Positive V-style insert (VCEX), GC1105	4
Positive D-style insert (DCGT), GC1105	4
2 mm insert for CoroCut 1-2, GC1125	4
Positive C-style insert (CCGT), GC1105	4
QS stop	4
QS wedge	8



Metric

Ordering code	Shank size, mm	Holder	Qty	Insert	Qty	Wedge/stop	Qty
KIT-QS-M-ST-12	12 × 12	QS-SVJBR 1212E11-B1	1	VCEX 110301R-F 1105	4	QS-1212	4
		QS-SDJCR 1212E07	1	DCGT 070204-UM 1105	4	QS-351	5
		QS-SCLCR 1212E09	1	CCGT 09T304-UM 1105	4	QS-352	3
		QS-LF123E11-1212B	1	N123E2-0200-0002-CM 1125	4		
KIT-QS-M-ST-16	16 × 16	QS-SVJBR 1616E11-B1	1	VCEX 110301R-F 1105	4	QS-1616	4
		QS-SDJCR 1616E11	1	DCGT 11T304-UM 1105	4	QS-351	5
		QS-SCLCR 1616E09	1	CCGT 09T304-UM 1105	4	QS-352	3
		QS-LF123E11-1616B	1	N123E2-0200-0002-CM 1125	4		

Imperial

Ordering code	Shank size, inch	Holder	Qty	Insert	Qty	Wedge/stop	Qty
KIT-QS-A-ST-0500	0.5 × 0.5	QS-SVJBR 082X-B1	1	VCEX 110301R-F 1105	4	QS-A08	4
		QS-SDJCR 083X	1	DCGT 11T304-UM 1105	4	QS-351	5
		QS-SCLCR 083X	1	CCGT 09T304-UM 1105	4	QS-352	3
		QS-LF123E043-08B	1	N123E2-0200-0002-CM 1125	4		
KIT-QS-A-ST-0625	0.625 × 0.625	QS-SVJBR 102X-B1	1	VCEX 110301R-F 1105	4	QS-A10	4
		QS-SDJCR 103X	1	DCGT 11T304-UM 1105	4	QS-351	5
		QS-SCLCR 103X	1	CCGT 09T304-UM 1105	4	QS-352	3
		QS-LF123E043-10B	1	N123E2-0200-0002-CM 1125	4		

Sliding head machines – Star

External turning – QS™ holding system for quick change with high precision coolant

Included products	Qty
QS holder for positive V-style insert (VCEX)	1
QS holder for positive D-style insert (DCGT)	1
QS holder for CoroCut® QD parting off insert	1
QS holder for positive C-style insert (CCGT)	1
QS holder for CoroThread® 266 threading insert	1
Positive V-style insert (VCEX), GC1105	4
Positive D-style insert (DCGT), GC1105	4
2 mm parting insert for CoroCut® QD, GC1125	4
Positive C-style insert (CCGT), GC1105	4
Threading insert for CoroThread® 266 holder, GC1135	4
QS stop	5
QS wedge	10
Coolant connector	5



Metric

Ordering code	Shank size, mm	Holder	Qty	Insert	Qty	Wedge/stop	Qty
KIT-QS-M-ST-12HP	12 × 12	QS-SVJCR 1212E11HP	1	VCEX 110301R-F 1105	4	QS-1212HP-M	5
		QS-SDJCR 1212E07HP	1	DCGT 070204-UM 1105	4	QS-351	6
		QS-SCLCR 1212E09HP	1	CCGT 09T304-UM 1105	4	QS-352	4
		QS-QD-LFE16C1212S	1	QD-NE-0200-0002-CM 1125	4	5696 001-01	5
		QS-266RFA-1212-16HP	1	266RG-16MM01A150M 1135	4		
KIT-QS-M-ST-16HP	16 × 16	QS-SVJCR 1616E11HP	1	VCEX 110301R-F 1105	4	QS-1616HP-M	5
		QS-SDJCR 1616E11HP	1	DCGT 11T304-UM 1105	4	QS-351	6
		QS-SCLCR 1616E09HP	1	CCGT 09T304-UM 1105	4	QS-352	4
		QS-QD-LFE20C1616S	1	QD-NE-0200-0002-CM 1125	4	5696 001-01	5
		QS-266RFA-1616-16HP	1	266RG-16MM01A150M 1135	4		

Imperial

Ordering code	Shank size, inch	Holder	Qty	Insert	Qty	Wedge/stop	Qty
KIT-QS-A-ST-0500HP	0.5 × 0.5	QS-SVJCR 082XHP	1	VCEX 110301R-F 1105	4	QS-A08HP-M	5
		QS-SDJCR 082XHP	1	DCGT 070204-UM 1105	4	QS-351	6
		QS-SCLCR 083XHP	1	CCGT 09T304-UM 1105	4	QS-352	4
		QS-QD-LFE0625C08S	1	QD-NE-0200-0002-CM 1125	4	5696 001-01	5
		QS-266RFA-083HP	1	266RG-16UN01A180M 1135	4		
KIT-QS-A-ST-0625HP	0.625 × 0.625	QS-SVJCR 102XHP	1	VCEX 110301R-F 1105	4	QS-A10HP-M	5
		QS-SDJCR 103XHP	1	DCGT 11T304-UM 1105	4	QS-351	6
		QS-SCLCR 103XHP	1	CCGT 09T304-UM 1105	4	QS-352	4
		QS-QD-LFE0800C10S	1	QD-NE-0200-0002-CM 1125	4	5696 001-01	5
		QS-266RFA-103HP	1	266RG-16UN01A180M 1135	4		

Sliding head machines – Tsugami

Internal turning – CoroTurn® XS

Included products	Qty
Holder for CoroTurn® XS size 4 insert	1
Boring insert for CoroTurn® XS, GC1025	4
Threading insert for CoroTurn® XS, GC1025	2
Grooving insert for CoroTurn® XS, GC1025	2



Ordering code	Shank size, mm	Holder	Qty	Insert	Qty
KIT-CXS-M-TG-25	25	CXS-A25-04	1	CXS-04T098A15-4210R 1025	4
				CXS-04G100-4215R 1025	2
				CXS-04TH050VM-4215R 1025	2

Sliding head machines – Tsugami

External turning – quick change with QS™ holding system

Included products	Qty
QS holder for positive V-style insert (VCEX)	1
QS holder for positive D-style insert (DCGT)	1
QS holder for CoroCut® 1-2 parting off insert	1
QS holder for positive C-style insert (CCGT)	1
Positive V-style insert (VCEX), GC1105	4
Positive D-style insert (DCGT), GC1105	4
2 mm insert for CoroCut 1-2, GC1125	4
Positive C-style insert (CCGT), GC1105	4
QS stop	4
QS wedge	4



Metric

Ordering code	Shank size, mm	Holder	Qty	Insert	Qty	Wedge/stop	Qty
KIT-QS-M-TG-12	12 × 12	QS-SVJBR 1212E11-B1	1	VCEX 110301R-F 1105	4	QS-130-12	4
		QS-SDJCR 1212E07	1	DCGT 070204-UM 1105	4	QS-130	4
		QS-SCLCR 1212E09	1	CCGT 09T304-UM 1105	4		
		QS-LF123E11-1212B	1	N123E2-0200-0002-CM 1125	4		
KIT-QS-M-TG-16	16 × 16	QS-SVJBR 1616E11-B1	1	VCEX 110301R-LF 1105	4	QS-130-16	4
		QS-SDJCR 1616E11	1	DCGT 11T304-UM 1105	4	QS-130	4
		QS-SCLCR 1616E09	1	CCGT 09T304-UM 1105	4		
		QS-LF123E11-1616B	1	N123E2-0200-0002-CM 1125	4		

Imperial

Ordering code	Shank size, inch	Holder	Qty	Insert	Qty	Wedge/stop	Qty
KIT-QS-A-TG-0500	0.5 × 0.5	QS-SVJBR 082X-B1	1	VCEX 110301R-F 1105	4	QS-130-12	4
		QS-SDJCR 083X	1	DCGT 11T304-UM 1105	4	QS-130	4
		QS-SCLCR 083X	1	CCGT 09T304-UM 1105	4		
		QS-LF123E043-08B	1	N123E2-0200-0002-CM 1125	4		
KIT-QS-A-TG-0625	0.625 × 0.625	QS-SVJBR 102X-B1	1	VCEX 110301R-F 1105	4	QS-130-16	4
		QS-SDJCR 103X	1	DCGT 11T304-UM 1105	4	QS-130	4
		QS-SCLCR 103X	1	CCGT 09T304-UM 1105	4		
		QS-LF123E043-10B	1	N123E2-0200-0002-CM 1125	4		

Sliding head machines – Tsugami

External turning – QS™ holding system for quick change with high precision coolant

Included products	Qty
QS holder for positive V-style insert (VCEX)	1
QS holder for positive D-style insert (DCGT)	1
QS holder for CoroCut® QD parting off insert	1
QS holder for positive C-style insert (CCGT)	1
QS holder for CoroThread® 266 threading insert	1
Positive V-style insert (VCEX), GC1105	4
Positive D-style insert (DCGT), GC1105	4
2 mm parting insert for CoroCut® QD, GC1125	4
Positive C-style insert (CCGT), GC1105	4
Threading insert for CoroThread® 266 holder, GC1135	4
QS stop	5
QS wedge	10
Coolant connector	5



Metric

Ordering code	Shank size, mm	Holder	Qty	Insert	Qty	Wedge/stop	Qty
KIT-QS-M-TG-12HP	12 × 12	QS-SVJCR 1212E11HP	1	VCEX 110301R-F 1105	4	QS-1212HP-M	5
		QS-SDJCR 1212E07HP	1	DCGT 070204-UM 1105	4	QS-140	5
		QS-SCLCR 1212E09HP	1	CCGT 09T304-UM 1105	4	QS-140HP	5
		QS-QD-LFE16C1212S	1	QD-NE-0200-0002-CM 1125	4	5696 001-01	5
		QS-266RFA-1212-16HP	1	266RG-16MM01A150M 1135	4		
KIT-QS-M-TG-16HP	16 × 16	QS-SVJCR 1616E11HP	1	VCEX 110301R-F 1105	4	QS-1616HP-M	5
		QS-SDJCR 1616E11HP	1	DCGT 11T304-UM 1105	4	QS-150	10
		QS-SCLCR 1616E09HP	1	CCGT 09T304-UM 1105	4	5696 001-01	5
		QS-QD-LFE20C1616S	1	QD-NE-0200-0002-CM 1125	4		
		QS-266RFA-1616-16HP	1	266RG-16MM01A150M 1135	4		

Imperial

Ordering code	Shank size, inch	Holder	Qty	Insert	Qty	Wedge/stop	Qty
KIT-QS-A-TG-0500HP	0.5 × 0.5	QS-SVJCR 082XHP	1	VCEX 110301R-F 1105	4	QS-A08HP-M	5
		QS-SDJCR 082XHP	1	DCGT 070204-UM 1105	4	QS-140	5
		QS-SCLCR 083XHP	1	CCGT 09T304-UM 1105	4	QS-140HPA	5
		QS-QD-LFE0625C08S	1	QD-NE-0200-0002-CM 1125	4	5696 001-01	5
		QS-266RFA-083HP	1	266RG-16UN01A180M 1135	4		
KIT-QS-A-TG-0625HP	0.625 × 0.625	QS-SVJCR 102XHP	1	VCEX 110301R-F 1105	4	QS-A10HP-M	5
		QS-SDJCR 103XHP	1	DCGT 11T304-UM 1105	4	QS-150	10
		QS-SCLCR 103XHP	1	CCGT 09T304-UM 1105	4	5696 001-01	5
		QS-QD-LFE0800C10S	1	QD-NE-0200-0002-CM 1125	4		
		QS-266RFA-103HP	1	266RG-16UN01A180M 1135	4		

