

# Mazak

## Quick Turn Smart 100, 150 M(S)

Toolholder Program



# Quick Turn Smart 100, 150 M(S)

Coromant Capto® Program

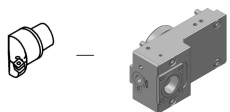
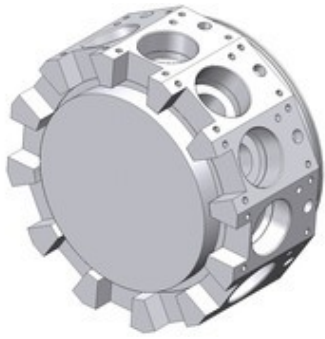

## OD clamping unit

C4	C4-TRE-MZ68B	Standard
C4	C4-TLE-MZ68B	Standard

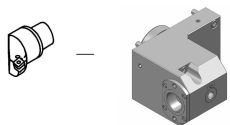

## Face and ID clamping unit

C4	C4-TRI-MZ68C	Standard
C4	C4-TLI-MZ68C	Standard

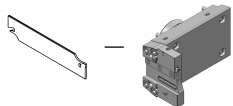

## Cut-off holder, adjustable, IC

SH 32	APBR-MZ68B-25-HP IC 80 bar	Standard
SH 32	APBL-MZ68B-25-HP IC 80 bar	Standard

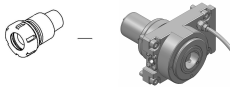

## OD drill/milling unit

C4	C4-DNE-MZ68B-E	1:1	EC	Standard
C4	C4-DNE-MZ68B-I	1:1	IC 80 bar	Standard

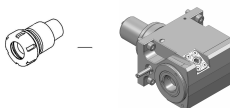

## Face drill/milling unit

C4	C4-DNI-MZ68B-E	1:1	EC	Standard
C4	C4-DNI-MZ68B-I	1:1	IC 80 bar	Standard

# Turning applications

Tool holder	Insert/Tool	Insert
T-Max® P	 > CNMG	
CoroTurn® 107	 > CCMT	
T-Max® P	 > DNMG	
CoroTurn® 107	 > DCMT	
CoroTurn® 107	 > VBMT	
CoroThread® 266	 > 266	
CoroTurn® SL	 > CoroTurn® 107	 > TCMT
CoroTurn® 107		
CoroTurn® 107		
Silent Tools™	 > CoroTurn® 107	 > VBMT
Drill adaptor	 > CoroDrill® 870	 > Exchangeable drill tip
	 > CoroDrill® 881	 > Indexable drilling insert
	 > EasyFix	 > Boring bars
		 > Boring bars
		 > Boring bars

## Rotating applications

Tool holder	Insert/Collet/Tool	Insert
Coromant EH	 > CoroMill® 316	
	 > CoroMill® 390	 > R390 
	 > CoroMill® 490	 > 490R 
	 > CoroMill® 216	 > R216 
	 > CoroMill® 300	 > R300 
	 > CoroBore® 824	 > CXS 
	 > CoroBore® 825	 > TCMT 
CoroChuck™ 930	 > Cylindrical collet	 > CoroMill® Plura 
		 > CoroDrill® 860 
ER collet chuck	 > ER collet	 > CoroMill® Plura 
		 > CoroDrill® 860 
CoroMill® 390	 > R390	