

KEYSLOT MOUNTING HOLES
(2) .44/88 DIA
[11]/[22]

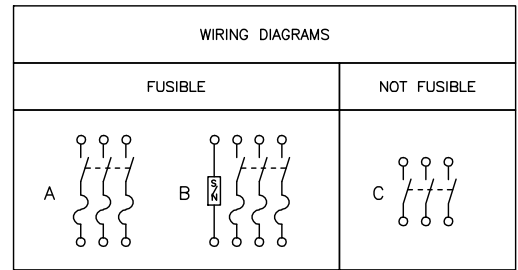
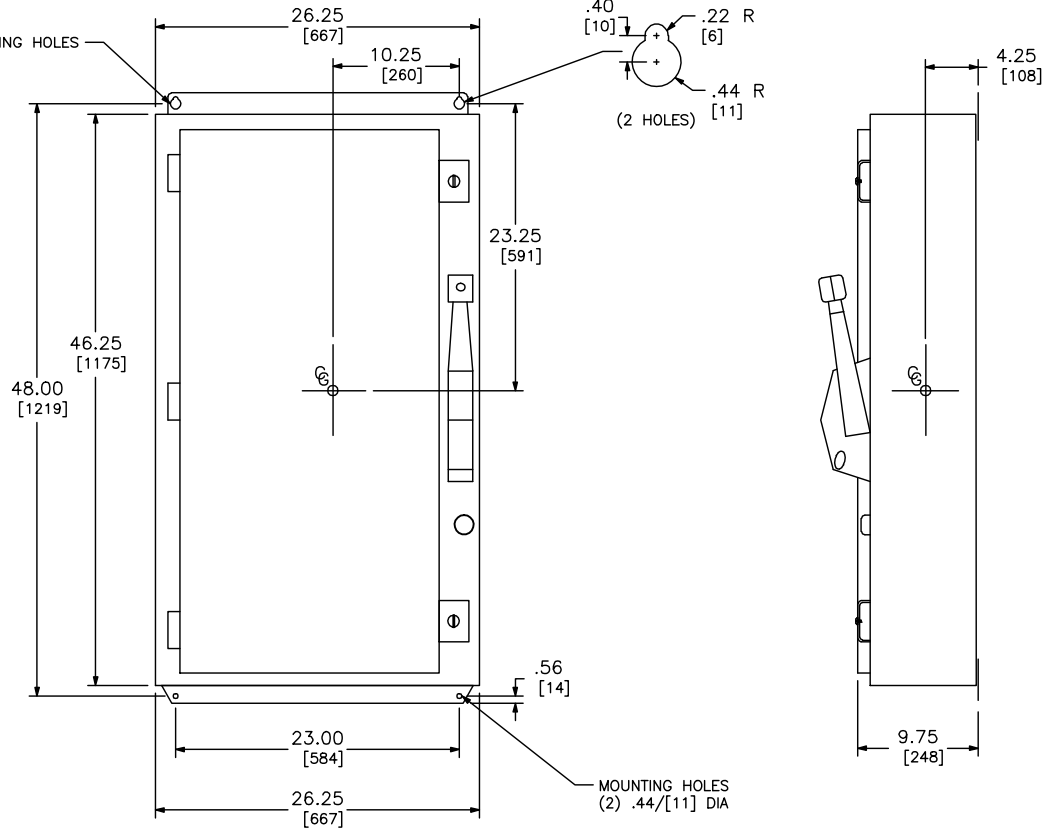

TERMINAL LUG DATA

AMPERES	MAX WIRE	MIN WIRE	TYPE
400	(1) 600 KCMIL OR	(1) 1/0 AWG OR	AL/CU
	(2) 300 KCMIL	(2) 1/0 AWG	

SEISMIC NOTES:
USE (4) 3/8" DIA GRADE 5 STEEL MOUNTING BOLTS @ HOLES AA
MAX CONFIGURED WEIGHT 155 LB (AWK CATALOG NUMBERS
157 LB (DS CATALOG NUMBERS) FOR THE PURPOSE OF DETERMINING
SEISMIC ANCHORAGE REQUIREMENTS. FOR ALL OTHER APPLICATIONS,
CONTACT SCHNEIDER ELECTRIC.

NEMA TYPE 4,4X,5 AND 12
NO KNOCKOUTS

DUAL DIMENSIONS: INCHES
MILLIMETERS

NOTES:
FINISH - NEMA TYPE 12 GRAY BAKED ENAMEL
NEMA 4, 4X, 5 TYPE 304 & 316 STAINLESS STEEL

UL LISTED - FILE E-154828

ALL NEUTRALS - INSULATED GROUNDABLE
SUITABLE FOR USE AS SERVICE EQUIPMENT

SHORT CIRCUIT CURRENT RATINGS:

10,000 AMPERES WHEN USED WITH OR PROTECTED BY CLASS H OR K FUSES.
200,000 AMPERES WHEN USED WITH OR PROTECTED BY CLASS R FUSES HAVING
CLASS R REJECTION KITS INSTALLED OR CLASS J FUSES.

CATALOG NUMBER			VOLTAGE RATINGS	WIRING DIAG	HORSEPOWER RATINGS							
NEMA TYPE 12	NEMA TYPE 4,4X,5 304 STAINLESS STEEL	NEMA TYPE 4,4X,5 316 STAINLESS STEEL			240VAC		480VAC		600VAC		250 VDC	600 VDC
					STD	MAX	STD	MAX	STD	MAX	MAX.	MAX.
H325AWK	H325DS	H325SS	240VAC	A	50	125	-	-	-	-	50	-
H325NAWK	H325NDS	H325NSS	240VAC	B	50	125	-	-	-	-	50	-
H365AWK	H365DS	H365SS	600VAC;600VDC	A	-	-	100	250	125	350	-	50
H365NAWK	H365NDS	H365NSS	600VAC	B	-	-	100	250	125	350	-	-
HU365AWK	HU365DS	HU365SS	600VAC;600VDC	C	-	125	-	250	-	350	-	50

HEAVY DUTY SAFETY SWITCHES
VISIBLE BLADE TYPE
400 AMPERES
ENCLOSURE - NEMA TYPE 12
NEMA TYPE 4, 4X, 5 STAINLESS STEEL;



DWG# 2147S
NO.