

REV	DESCRIPTION	BY	DATE				
---	---	---	---	---	---	---	---

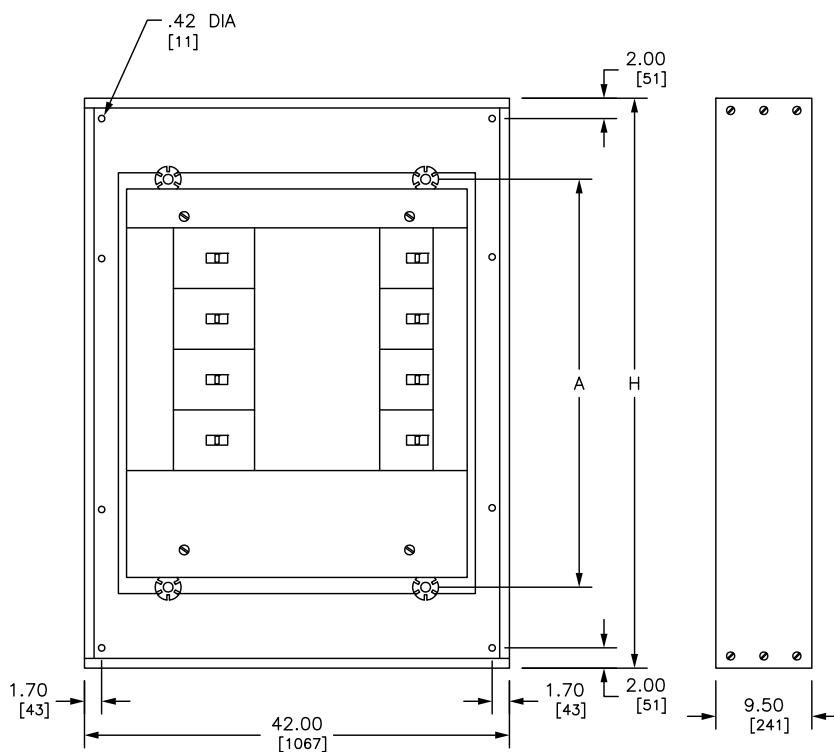

TYPICAL BOX WITH INTERIOR

TYPICAL BOX SIDE VIEW

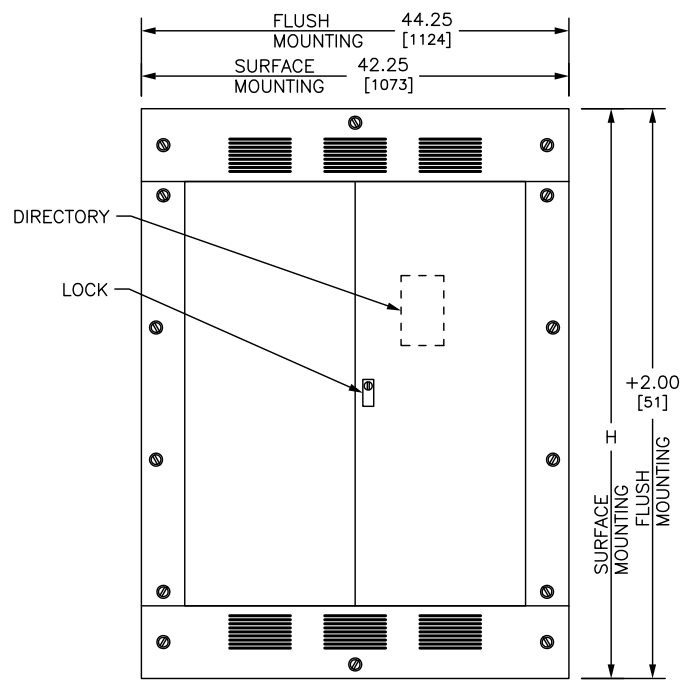

TYPICAL FRONT
(4 PIECE TRIM - WITH DOOR)

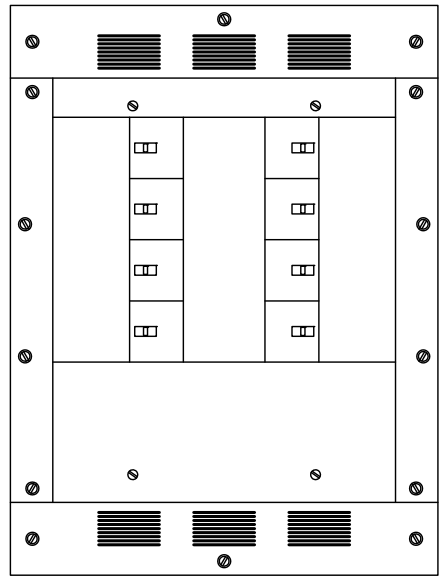

TYPICAL SURFACE FRONT
(4 PIECE TRIM - NO DOOR)

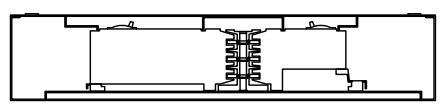

TYPICAL MOUNTING OF DG, DJ, DL, FA, FC, FD, FG, FH, FI, FJ, FK, FY, HD, HG, HJ, HL, JD, JG, JJ, JL, KA, KC, KH, KI, LA, LC, LE, LH, LI, LX, LXI, MG, MJ, PG, PJ, PK, PL, Q2, Q2H, Q2-H, QB, QD, QG, QJ, OR QO, BREAKERS

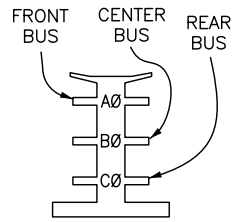

BRANCH CONNECTION PHASING IS DETERMINED BY CIRCUIT BREAKER SELECTION

REFER TO DP CATALOG CLASS 2110 FOR ADDITIONAL INFORMATION

I-LINE HCP PANELBOARDS MEET THE APPLICABLE REQUIREMENTS OF UL AND CSA.

BOX: CODE GAUGE GALVANIZED STEEL WITH REMOVABLE BLANK ENDWALLS.

FRONT: CODE GAUGE STEEL, GRAY BAKED ENAMEL FISHISH ELECTRODEPOSITED OVER CLEANED PHOSPHATIZED STEEL.

LOCK: (COVERS WITH DOORS) HAVE 3 POINT ESCUTCHEON FLUSH LOCK WITH NSR-251 KEY.

FOR NEMA TYPE 3R APPLICATIONS USE IN CONJUNCTION WITH PBA412.

DUAL DIMENSIONS: INCHES MILLIMETERS

MAXIMUM MLO OR BF-MCB AMPERE RATING	BRANCH BREAKER MOUNTING SPACE (INCHES)	H		A	
		IN	MM	IN	MM
225A THRU 800A	27	50.00	1270	20.40	518
	45	59.00	1499	38.40	975
	63	68.00	1727	47.40	1204
	99	86.00	2184	65.10	1654

JOB NAME: ---	EQUIPMENT DESIGNATION: ---
JOB LOCATION: ---	EQUIPMENT TYPE: I-LINE HCP MLO OR BF-MCB
DRAWN BY: ---	DRAWING TYPE: ---
ENGR: ---	
DATE: MARCH 2018	
DRAWING STATUS: ---	DWG# PBA418

