

MALE END VIEW

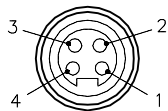

SPECIFICATIONS

HOUSING MATERIAL/COLOR	PBT or NYLON/BLACK
CONTACT MATERIAL/PLATING	BRASS/GOLD
COUPLING NUT MATERIAL/PLATING	DIECAST ZINC/NICKEL
RATED CURRENT [A]	9.0 A
RATED VOLTAGE [V]	600 V
MAXIMUM WIRE SIZE	16 AWG
TERMINATION METHOD	SCREW TERMINAL
CABLE GRIP RANGE	10-12mm
TEMPERATURE RATING	-25°C to +85°C (-13°F to +185°F)
PROTECTION CLASS	IP67

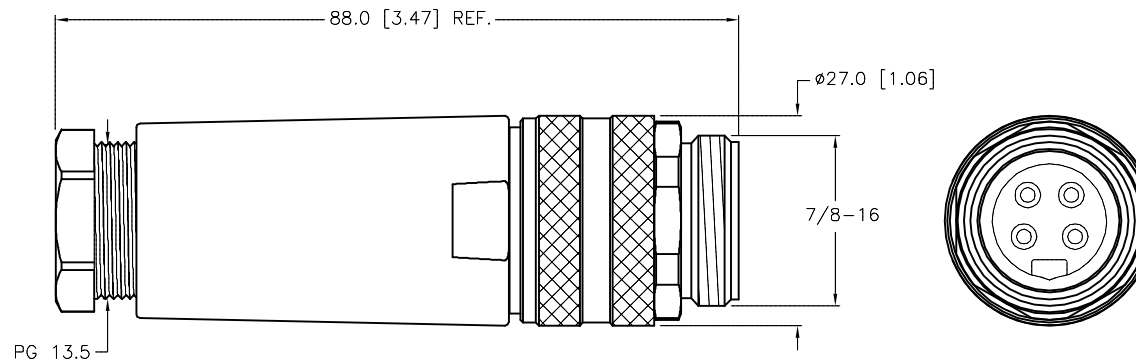

SOURCE DRAWING - FOR REFERENCE ONLY

NOTES:

1. PIN #4 IS A PRE-MATE PIN.

RELATED DOCUMENTS		3RD ANGLE PROJECTION		THIS DOCUMENT IS PROPERTY OF TURCK INC. USE OF THIS DOCUMENT WITHOUT WRITTEN PERMISSION IS PROHIBITED.		 3000 CAMPUS DRIVE MINNEAPOLIS, MN 55441 1-800-544-7769 (612) 553-7300 (612) 553-0708 fax www.turck.com	
1.			ALL DIMENSIONS DISPLAYED ON THIS DRAWING ARE FOR REFERENCE ONLY	DRFT	RDS	DATE	03/15/13
2.				APVD	T.S.	SCALE	1=1.0
3.		MATERIAL		UNIT OF MEASUREMENT		IDENTIFICATION NO.	
4.		SEE SPECIFICATIONS		MILLIMETER [INCH]		U6415-0	
FINISH		CONTACT TURCK FOR MORE INFORMATION		DO NOT SCALE THIS DRAWING		REV	
SEE SPECIFICATIONS						B	
SEE SPECIFICATIONS						FILE: U6415-0	
						SHEET 1 OF 1	

B	UPDATE VOLTAGE & TEMP	NF	02/19/15	49070
REV	DESCRIPTION	BY	DATE	ECO NO.