

FEMALE END VIEW

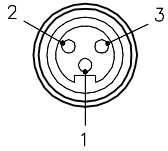

SPECIFICATIONS

HOUSING MATERIAL/COLOR	PBT or NYLON/BLACK
CONTACT MATERIAL/PLATING	BRASS/GOLD
COUPLING NUT MATERIAL/PLATING	DIECAST ZINC/NICKEL
RATED CURRENT [A]	12.0 A
RATED VOLTAGE [V]	600 V
MAXIMUM WIRE SIZE	16 AWG
TERMINATION METHOD	SCREW TERMINAL
CABLE GRIP RANGE	6-8mm
TEMPERATURE RATING	-25°C to +85°C (-13°F to +185°F)
PROTECTION CLASS	IP67

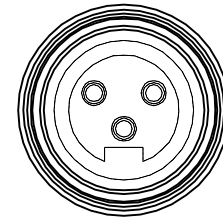
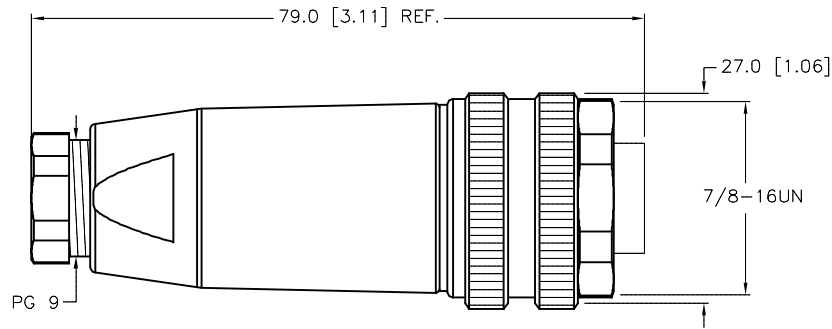

SOURCE DRAWING - FOR REFERENCE ONLY

RELATED DOCUMENTS		3RD ANGLE PROJECTION		THIS DOCUMENT IS PROPERTY OF TURCK INC. USE OF THIS DOCUMENT WITHOUT WRITTEN PERMISSION IS PROHIBITED.		<b>TURCK IAC</b> High Technology Sensors and Automation Controls 3000 CAMPUS DRIVE MINNEAPOLIS, MN 55441 1-800-544-7769 (612) 553-7300 (612) 553-0708 fax www.turck.com		
1.			ALL DIMENSIONS DISPLAYED ON THIS DRAWING ARE FOR REFERENCE ONLY	DRFT	RDS	DATE	12/16/10	
2.				APVD		SCALE	1=1.0	DESCRIPTION
3.				UNIT OF MEASUREMENT			IDENTIFICATION NO.	REV
4.			CONTACT TURCK FOR MORE INFORMATION	MILLIMETER [ INCH ]			U6310	B
MATERIAL		SEE SPECIFICATIONS		DO NOT SCALE THIS DRAWING			FILE: U6310	SHEET 1 OF 1
FINISH		SEE SPECIFICATIONS						

B	UPDATE VOLTAGE & TEMP	NF	02/19/15	49070
REV	DESCRIPTION	BY	DATE	ECO NO.