

SPECIFICATIONS	
CONTACT CARRIER MATERIAL/COLOR	NYLON OR TPU/BLACK
CONTACT MATERIAL/PLATING	BRASS/GOLD
HOUSING, LOCKNUT/PLATING	BRASS/NICKEL
RATED CURRENT [A]	2.0 A
RATED VOLTAGE [V]	60VAC/75VDC
NUMBER OF CONDUCTORS [AWG]	SOLDER CUPS
TEMPERATURE RANGE	-40°C to +105°C (-40°F to +221°F)
PROTECTION CLASS	MEETS NEMA 1,3,4,6P AND IEC IP68
MAX. PANEL THICKNESS	3.0 [0.12]

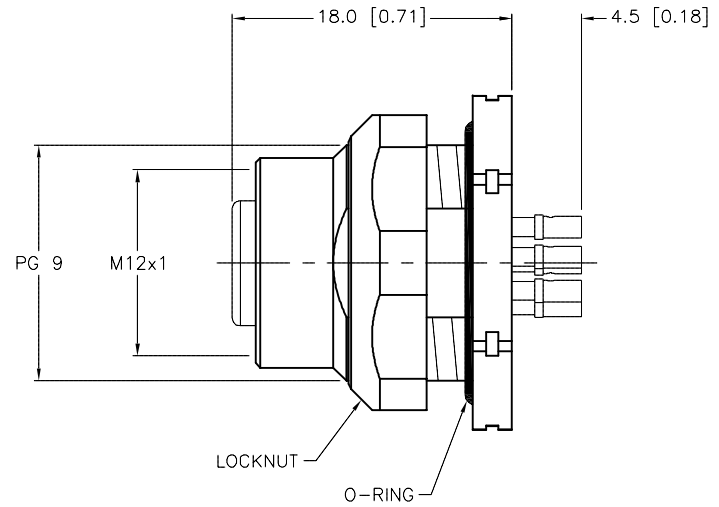
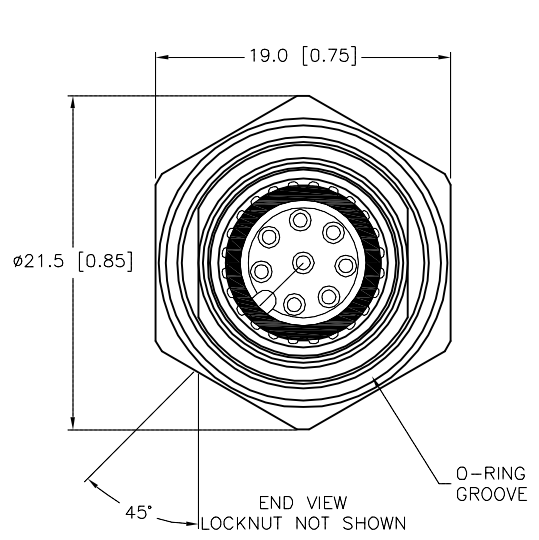

SOURCE DRAWING - FOR REFERENCE ONLY

RELATED DOCUMENTS		3RD ANGLE PROJECTION		THIS DRAWING IS CONFIDENTIAL AND THE PROPERTY OF TURCK INC. USE OF THIS DOCUMENT WITHOUT WRITTEN PERMISSION IS PROHIBITED.		TURCK INC High Technology Sensors and Automation Controls 3000 CAMPUS DRIVE MINNEAPOLIS, MN 55441 1-800-544-7769 (763) 553-7300 (763) 553-0708 fax turck.com	
1.			DRFT	RDS	DATE	05/11/06	DESCRIPTION FKFDL 84
2.			DSGN		SCALE	1=.5	
3.		ALL DIMENSIONS DISPLAYED ON THIS DRAWING ARE FOR REFERENCE ONLY CONTACT TURCK FOR MORE INFORMATION	UNIT OF MEASUREMENT		IDENTIFICATION NO.		REV
4.			MILLIMETER [INCH]		U3-00839		C
MATERIAL		SEE SPECIFICATIONS		DO NOT SCALE THIS DRAWING		FILE: U3-00839	
FINISH		SEE SPECIFICATIONS		SHEET 1 OF 1			

C	DRAWING PROCESSED AS PART OF ECO 33971	CBM	04/07/11	33971
REV	DESCRIPTION	BY	DATE	ECO NO.