

SPECIFICATIONS	
CONTACT CARRIER MATERIAL	NYLON or TPU
MOLDED HEAD MATERIAL/COLOR	PVC/BLACK
CONTACT MATERIAL/PLATING	BRASS/GOLD
COUPLING NUT MATERIAL/FINISH	STAINLESS STEEL/PASSIVATED
RATED CURRENT [A]	4.0 A
RATED VOLTAGE [V]	250 V
OUTER JACKET MATERIAL/COLOR	PVC/GREY
CONDUCTOR INSULATION MATERIAL	PVC
NUMBER OF CONDUCTORS [AWG]	4x22 AWG
TEMPERATURE RANGE	-40°C to +105°C (-40°F to +221°F)
PROTECTION CLASS	MEETS NEMA 1,3,4,6P AND IEC IP68

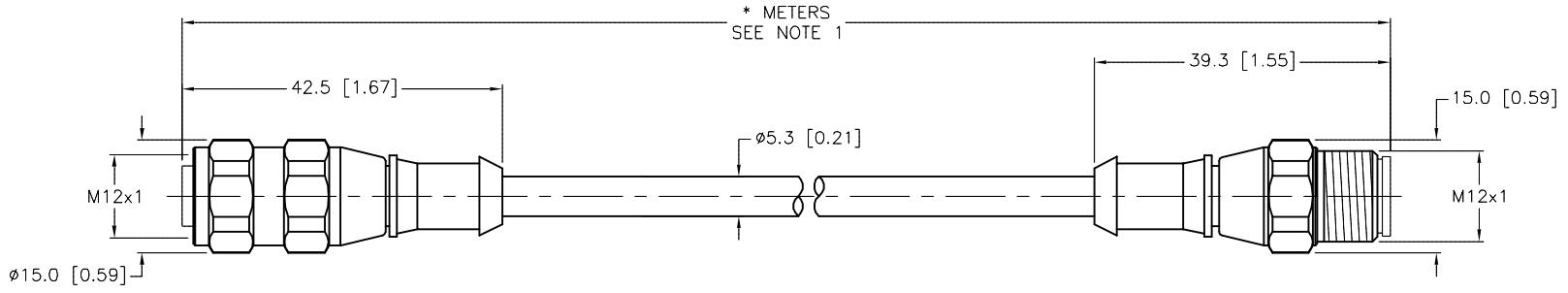

CABLE LENGTH	TOLERANCE*
ALL LENGTHS	+ 4% (OR 50mm) OF LENGTH - 0% (OR 0mm) OF LENGTH WHICHEVER IS GREATER
STRIP LENGTH	TOLERANCE*
0-7mm	±0.5mm
8-29mm	±1.0mm
30-49mm	±2.0mm
50-69mm	±3.0mm
70-100mm	±4.0mm
OVER 100mm	±5.0mm

\* UNLESS OTHERWISE SPECIFIED

- NOTES:
- "\*" INDICATES CABLE LENGTH IN METERS. CONTACT TURCK TO ORDER SPECIFIC LENGTHS.
  - "/S824" DESIGNATES PLTC CABLE HAVING CSA "FT-4" FLAME RATING.
  - "/S771" DESIGNATES STANDARD CORDSET WITH BLACK PLUG BODY.
  - "/CS10455" DESIGNATES PVC PLUG BODY AND NYLON OR TPU CONTACT CARRIER.

SOURCE DRAWING - FOR REFERENCE ONLY

RELATED DOCUMENTS 1. 2. 3. 4.	3RD ANGLE PROJECTION 	THIS DRAWING IS CONFIDENTIAL AND THE PROPERTY OF TURCK INC. USE OF THIS DOCUMENT WITHOUT WRITTEN PERMISSION IS PROHIBITED.		3000 CAMPUS DRIVE MINNEAPOLIS, MN 55441 1-800-544-7769 (763) 553-7300 (763) 553-0708 fax turck.com	
		MATERIAL  SEE SPECIFICATIONS	DRFT KF DATE 10/26/06	DESCRIPTION RKV 4.4T-*--RSV 4.4T/S824/S771/CS10455	
FINISH  SEE SPECIFICATIONS	ALL DIMENSIONS DISPLAYED ON THIS DRAWING ARE FOR REFERENCE ONLY  CONTACT TURCK FOR MORE INFORMATION	APVD	SCALE 1=1.0	UNIT OF MEASUREMENT <b>MILLIMETER [ INCH ]</b>	
DO NOT SCALE THIS DRAWING		FILE: 777014317		REV C	

C	UPDATE DESCRIPTION	NF	06/24/16	55590
REV	DESCRIPTION	BY	DATE	ECO NO.