

FEMALE END VIEW

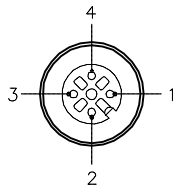

- 1 = BROWN
- 2 = WHITE
- 3 = BLUE
- 4 = BLACK



SPECIFICATIONS

CONTACT CARRIER MATERIAL	NYLON OR TPU
MOLDED HEAD MATERIAL/COLOR	TPU/YELLOW
CONTACT MATERIAL/PLATING	BRASS/GOLD
COUPLING NUT MATERIAL/PLATING	BRASS/NICKEL
RATED CURRENT [A]	4.0 A
RATED VOLTAGE [V]	250 V
OUTER JACKET MATERIAL/COLOR	TPU/YELLOW
INNER JACKET MATERIAL/COLOR	PVC/YELLOW
CONDUCTOR INSULATION MATERIAL	PVC
NUMBER OF CONDUCTORS [AWG]	4x20 AWG
SHIELDING	TINNED-COPPER BRAIDED
TEMPERATURE RATING	-40°C to +90°C (-40°F to +194°F)
PROTECTION CLASS	NEMA 1,3,4,6P AND IEC IP68, IP69K

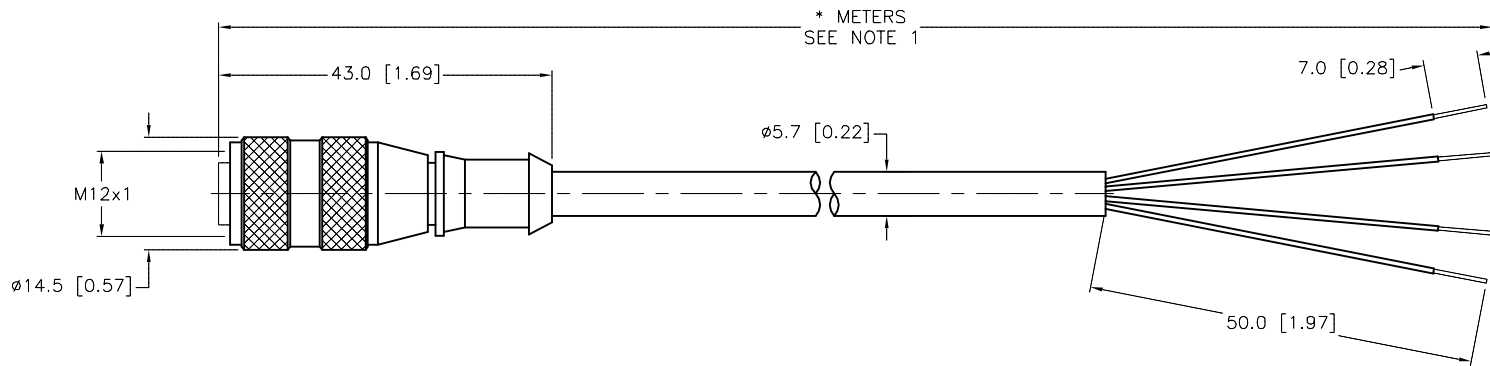

CABLE LENGTH	TOLERANCE*
ALL LENGTHS	+ 4% (OR 50mm) OF LENGTH - 0% (OR 0mm) OF LENGTH WHICHEVER IS GREATER
STRIP LENGTH	TOLERANCE*
0-7mm	±0.5mm
8-29mm	±1.0mm
30-49mm	±2.0mm
50-69mm	±3.0mm
70-100mm	±4.0mm
OVER 100mm	±5.0mm

\* UNLESS OTHERWISE SPECIFIED

NOTES:

- "\*" INDICATES CABLE LENGTH IN METERS. CONTACT TURCK TO ORDER SPECIFIC LENGTHS.
- "/S529" DESIGNATES CABLE CONSTRUCTION WITH THERMOPLASTIC POLYURETHANE (TPU) OVER SHIELD OVER PVC.

SOURCE DRAWING - FOR REFERENCE ONLY

RELATED DOCUMENTS		3RD ANGLE PROJECTION		THIS DRAWING IS CONFIDENTIAL AND THE PROPERTY OF TURCK INC. USE OF THIS DOCUMENT WITHOUT WRITTEN PERMISSION IS PROHIBITED.		3000 CAMPUS DRIVE MINNEAPOLIS, MN 55441 1-800-544-7769 (763) 553-7300 (763) 553-0708 fax turck.com	
1.			DRFT CBM DSGN	DATE 10/09/00	DESCRIPTION RK 4.41T-*/S529		
2.				SCALE 1=1.0			
3.		ALL DIMENSIONS DISPLAYED ON THIS DRAWING ARE FOR REFERENCE ONLY	UNIT OF MEASUREMENT <b>MILLIMETER [ INCH ]</b>		IDENTIFICATION NO.		REV
4.			CONTACT TURCK FOR MORE INFORMATION				
MATERIAL		SEE SPECIFICATIONS		DO NOT SCALE THIS DRAWING		FILE: 777000616	
FINISH		SEE SPECIFICATIONS				SHEET 1 OF 1	

I	DRAWING PROCESSED AS PART OF ECO 33971	CBM	04/06/11	33971
REV	DESCRIPTION	BY	DATE	ECO NO.