

MALE END VIEW

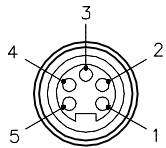

- 1 = BLACK
- 2 = BLUE
- 3 = GREEN/YELLOW
- 4 = BROWN
- 5 = WHITE



SPECIFICATIONS

CONTACT CARRIER MATERIAL	TPU
CONTACT MATERIAL/PLATING	BRASS/GOLD
HOUSING MATERIAL	BRASS/NICKEL
RATED CURRENT [A]	9.0 A
RATED VOLTAGE [V]	600 V
NUMBER OF CONDUCTORS [AWG]	5x18 AWG
TEMPERATURE RATING	-40°C to +105°C (-40°F to +221°F)
PROTECTION CLASS	MEETS NEMA 1,3,4,6P AND IEC IP67

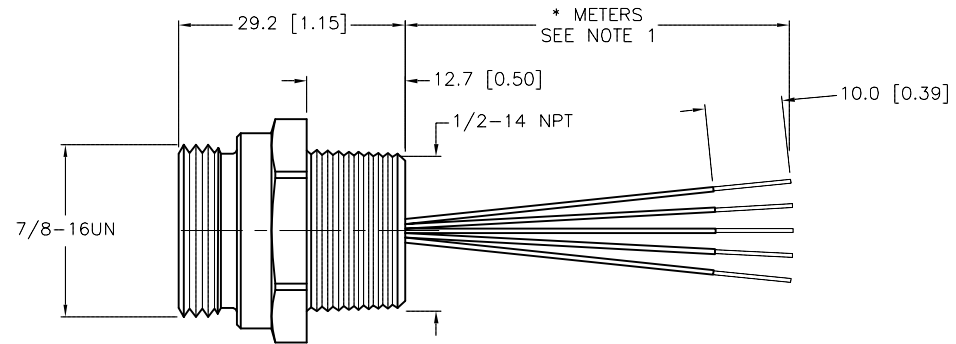
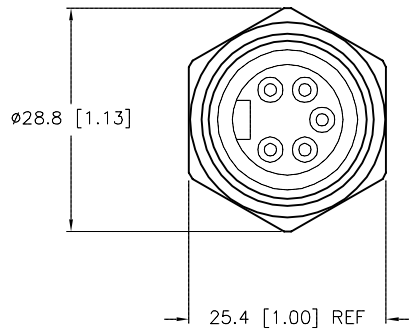

CABLE LENGTH	TOLERANCE *
ALL LENGTHS	+ 4% (OR 50mm) OF LENGTH - 0% (OR 0mm) OF LENGTH WHICHEVER IS GREATER
STRIP LENGTH	TOLERANCE *
0-7mm	±0.5mm
8-29mm	±1.0mm
30-49mm	±2.0mm
50-69mm	±3.0mm
70-100mm	±4.0mm
OVER 100mm	±5.0mm

* UNLESS OTHERWISE SPECIFIED

NOTES:

1. "*" INDICATES CABLE LENGTH IN METERS. CONTACT TURCK TO ORDER SPECIFIC LENGTHS.

SOURCE DRAWING - FOR REFERENCE ONLY

RELATED DOCUMENTS 1. 2. 3. 4.	3RD ANGLE PROJECTION 	THIS DRAWING IS CONFIDENTIAL AND THE PROPERTY OF TURCK INC. USE OF THIS DOCUMENT WITHOUT WRITTEN PERMISSION IS PROHIBITED.		3000 CAMPUS DRIVE MINNEAPOLIS, MN 55441 1-800-544-7769 (763) 553-7300 (763) 553-0708 fax turck.com	
	MATERIAL	DRFT RDS	DATE 01/02/08	DESCRIPTION RSF 50-*M/NPT	
FINISH	ALL DIMENSIONS DISPLAYED ON THIS DRAWING ARE FOR REFERENCE ONLY	APVD	SCALE 1=1	IDENTIFICATION NO.	
CONTACT TURCK FOR MORE INFORMATION		UNIT OF MEASUREMENT MILLIMETER [INCH]		REV B	
DO NOT SCALE THIS DRAWING		FILE: 777003082		SHEET 1 OF 1	

B	UPDATE RATED VOLTAGE	KMY	03/27/13	41679
REV	DESCRIPTION	BY	DATE	ECO NO.