

Accessories for Fieldbus Systems

VB2-FKM-FKM-FSM57

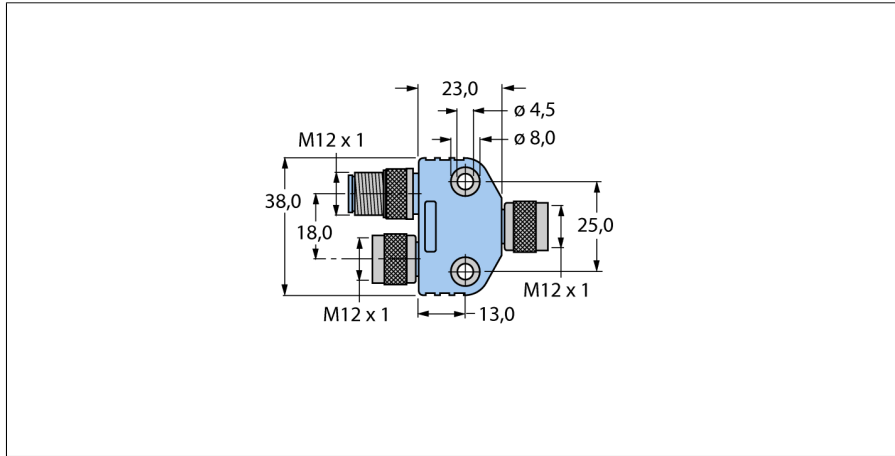

- Type: M12 adapter
- Y piece, 5-pin
- For use in CAN (DeviceNet™, CANopen) applications

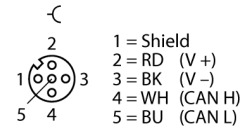
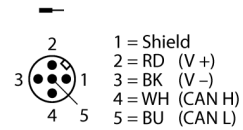
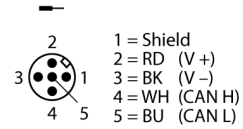

Type designation	VB2-FKM-FKM-FSM57
Ident-No.	6602331
Ident-No (TUSA)	U0095-5
Number of Pins	5
Grip	Plastic
Mechanical lifespan	> 100 mating cycles
Protection class	IP67, A + B side screwed together
Contacts	metal, CuZn, Gold-plated
Contact carriers	Plastic
Grip	plastic
Seal	plastic
Mechanical lifespan	> 100 contact durability
Protection class	IP67, only when plugged in
Rated Voltage	250 V
Ampacity	4 A
Insulation resistance	≥ 10 ⁹ Ω
Forward resistance	≤ 5 mΩ
Ambient temperature	
In motion	-40 ...+105°C

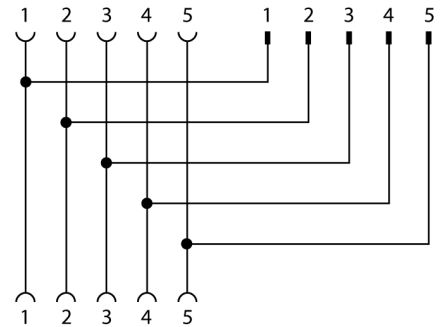

Accessories for Fieldbus Systems
 VB2-FKM-FKM-FSM57



<p>F061 F098 F065 F060</p>		<p> </p> <p> </p> <p> </p> <p> </p>
---	--	-------------------------------------