

REV. 2	SHEET 1 OF 2	DOCUMENT NO. UWWPCJ-27
REVISIONS		
LTR	DESCRIPTION	DATE
A	INITIAL RELEASE	03/15/10

Terry

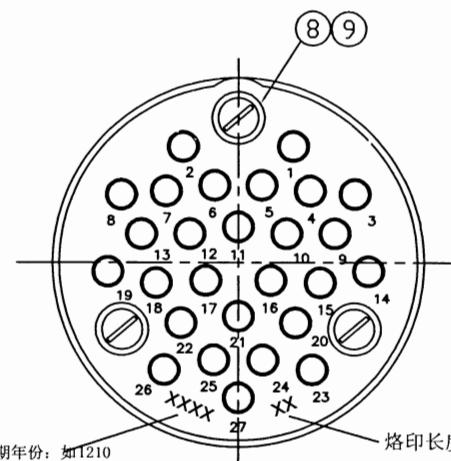

视图 A=视图 B



黄管弯曲方向

ORIGINAL COPY (正宗原版)
15 MAR 2010
DOCUMENT CONTROL

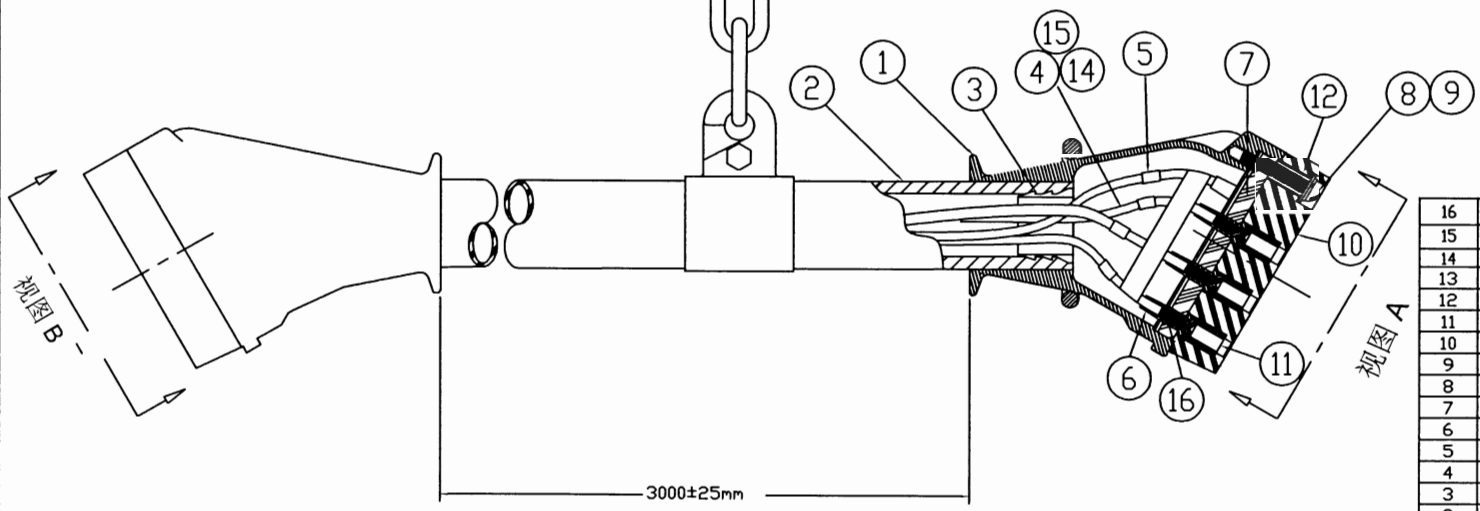

POS	QTY	PART NUMBER	DESCRIPTION	NOTE
16	38	C10-643033-000	镀银铜套环	
15	A/R	C120517	10AWG 灰色电缆	
14	A/R	C120540	14AWG 灰色电缆	
13	1	CML01-004-01	铁链组件	
12	6	CWWP-41-FL	铝套环	
11	54	CWWP-42-A	镀银母端子	
10	2	CWWP-41	黑色厚塑胶垫	
9	6	C101257	弹簧垫圈	
8	6	C101606	圆头长螺钉	
7	2	CWWP-12	电木薄绝缘板	
6	54	CWWR-24	短头塑胶套	
5	1	C160301	1-33号线位标签	
4	A/R	C120495	12AWG 灰色电线	
3	2	CWWP-64	原色铝压套	
2	A/R	C160499	黄管	
1	2	CWWP-65	保护盖, 无喷漆原色	

NOTES:

N/A
N/A
NEXT ASSEMBLY
METRIC DOCUMENT

PRO/ENGINEER INFORMATION
Pro/e Model Used: C10-647350.asn
Drawing Name: C10-647350
PRO/INTRALINK INFORMATION
RELEASE STATE: REVISION

UNLESS OTHERWISE SPECIFIED
LINEAR DIMENSIONS ARE IN MILLIMETERS
TOLERANCES
ANGLES= ±2°
NO DEFAULT LINEAR TOLERANCES
DIM & TOL. PER ASME Y14.5M-1994;
DIM PER MIL-DTL-31000;
OTHER AMPHENOL STANDARDS: 9-9318
LEGENDS:
△ = FLAG NOTE CALL OUT REFERENCE ONLY

SPECIFICATIONS
MATERIAL SPEC: N/A
PROCESS SPEC: N/A

APPROVALS
PREPARED BY: TERRY
ENGINEER IN CHARGE: Gary
DESIGN MANAGER: Gary
DESIGN ACTIVITIES GROUP: CLI

DATE: 03/15/10
AMPHENOL CORPORATION 40-60 DELAWARE AVENUE SIDNEY, N.Y. 13838

3 METRE LENGTH JUMPER PLUG ASSEMBLY

THIRD ANGLE PROJECTION
SIZE A2 CAGE CODE 77820 DOCUMENT NO. UWWPCJ-27 REV. A
SCALE: N/A REF. SHEET 1 OF 2

REV. A	SHEET 2 OF 2	DOCUMENT NO. UWWPCJ-27
REVISIONS		
LTR	DESCRIPTION	DATE
A	INITIAL RELEASE	03/15/10

Terry

WIRING DIAGRAM

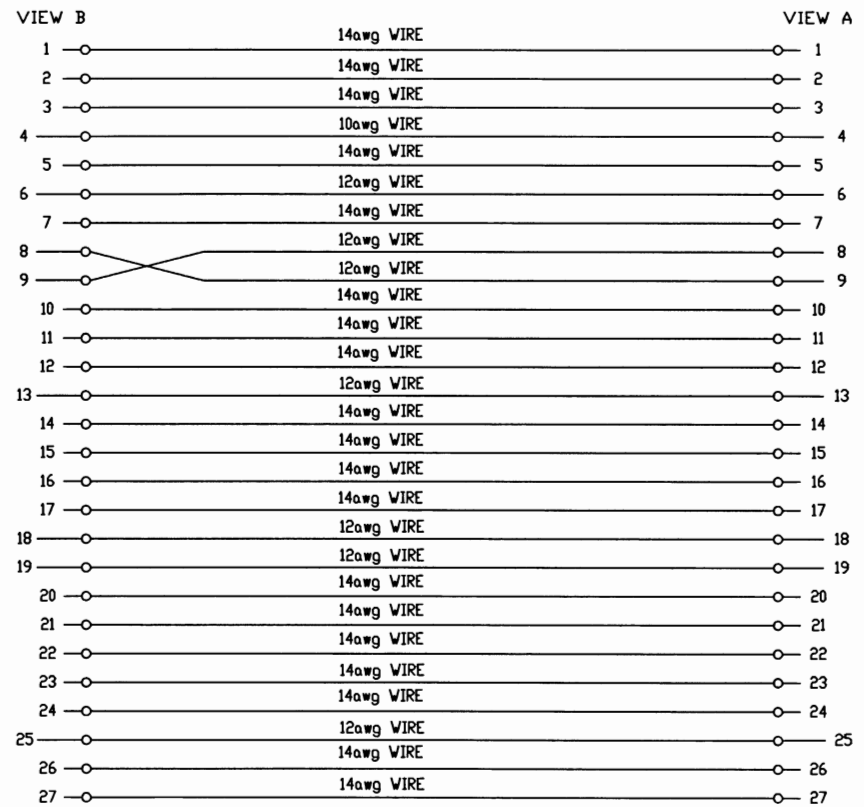

ORIGINAL COPY (正宗原版)
15 MAR 2010
DOCUMENT CONTROL

注意事项:

1. 请参照左图接线.
2. 电性能测试参数: 高压1500V AC, 60HZ, 20MOHM, 5秒.
3. 裁剪一条黄色胶管, 长度: 3137±5mm.
4. 裁剪19条14AWG电缆, 每条长度: 3487±5mm.
5. 裁剪7条12AWG电缆, 每条长度: 3487±5mm.
6. 裁剪1条10AWG电缆, 每条长度: 3487±5mm.
7. 所有电线穿过黄色胶管.
8. 所有电线两端去皮12--13mm.
9. 线位标签贴在距离电线末端150±10mm.
10. 铁链组装在黄管的中间位置.
11. 所有14AWG电线需套上镀银铜套环, 然后压端子.

NOTES:

N/A	PRO/ENGINEER INFORMATION
N/A	Pro/e Model Used
N/A	Drawing Name: C10-647350.asn
N/A	C10-647350
N/A	PRO/INTRALINK INFORMATION
N/A	RELEASE STATE: REVISION
N/A	METRIC DOCUMENT

UNLESS OTHERWISE SPECIFIED LINEAR DIMENSIONS ARE IN MILLIMETERS TOLERANCES: ANGLES= ±2° NO DEFAULT LINEAR TOLERANCES DIM & TOL PER ASME Y14.5M-1994, DRW PER MIL-DTL-31000 OTHER AMPHENOL STANDARDS: 9-9318	SPECIFICATIONS	POS	QTY	PART NUMBER	DESCRIPTION	NOTE
	MATERIAL SPEC.	APPROVALS		DATE	PARTS LIST	
	N/A	PREPARED BY: TERRY	DATE: 03/15/10	AMPHENOL CORPORATION 40-60 DELAWARE AVENUE SIDNEY, N.Y. 13838		
	PROCESS SPEC.	ENGINEER IN CHARGE: Gary	DESIGN MANAGER: Gary	3 METRE LENGTH JUMPER PLUG ASSEMBLY		
N/A	THIRD ANGLE PROJECTION	DESIGN ACTIVITIES GROUP: C&I		SIZE: A2	CAGE CODE: 77820	DOCUMENT NO.: UWWPCJ-27
LEGENDS: ⊕ = FLAG NOTE CALL OUT REFERENCE ONLY			SCALE: N/A	REF.	SHEET 2 OF 2	REV. A

DOCUMENT NO. UWWPCJ-27
 SHEET 2 OF 2
 REV. A
 D
 C
 B
 A
 FORMAT: A2-L-E-I

F
 E
 D
 C
 B
 A
 SHEET 2 OF 2
 REV. A
 DOCUMENT NO. UWWPCJ-27