

HUBBELL®
Wiring Device-Kellems



H-MOSS®

Sensors for an Energy
Conscious World



Smart Technologies for Smart Buildings

H-MOSS® Occupancy Sensors combine innovative technologies for industry proven performance.



Adaptive Technology

Adaptive Technology is a Hubbell breakthrough that delivers benefits to both building owners and occupants. The building owner achieves reduced energy costs, fewer adjustments and less maintenance, and the building occupant experiences fewer false-offs and disturbances.

Adaptive technology occupancy sensors use microprocessors that make all the decisions for setting adjustments. Internal software constantly monitors the controlled area and automatically adjusts the sensitivity and timer based on environmental history. This means that instead of manually adjusting the sensor for seasonal changes, modified airflow, furniture layout or occupancy pattern changes, the sensor automatically adjusts itself. These automatic adjustments eliminate the need for multiple manual adjustments by maintenance personnel or outside contractors. Hubbell offers adaptive technology throughout its product offering—wall switches, ceiling and wall mount sensors—in conjunction with dual technology, ultrasonic and passive infrared products.

How to Select the Right Technology for the Proper Application

Dual Technology

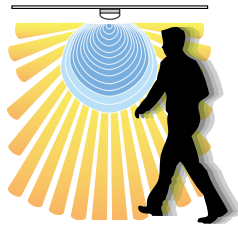

Dual technology occupancy sensors combine both passive infrared (PIR) and ultrasonic (US) technologies for maximum reliability. Because US and PIR need to both detect occupancy to turn lighting on, dual technology sensors minimize the risk of lights coming on when the space is unoccupied—false triggering. Continued detection by only one technology then keeps lighting on as necessary. Dual technology sensors offer the best performance for most applications.

Ultrasonic (US)

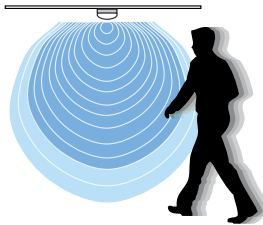

Ultrasonic (US) technology senses occupancy by bouncing sound waves (32 kHz - 45 kHz) off of objects and detecting a frequency shift between the emitted and reflected sound waves. Movement by a person or object within a space causes a shift in frequency, which the sensor interprets as occupancy. While US occupancy sensors have a limited range, they are excellent at detecting even minor motion such as typing and filing, and they do not require an unobstructed line-of-sight. This makes US technology sensors ideal for an application like an office with cubicles or a restroom with stalls.

Passive Infrared (PIR)

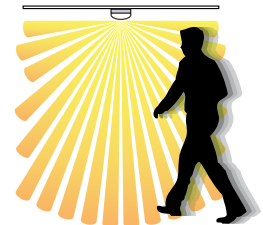

Passive infrared (PIR) technology senses occupancy by detecting the movement of heat emitted from the human body against the background space. Unlike US technology, PIR sensors require an unobstructed line-of-sight for detection. These sensors use a segmented lens, which divides the coverage area into zones. Movement between zones is then interpreted as occupancy. PIR sensors are ideal for detecting major motion (e.g. walking), and they work best in small, enclosed spaces with high levels of occupant movement.

Table of Contents

Overview	2-3
Solutions	
Office Solutions.....	4
Education Solutions.....	5
Healthcare Solutions.....	6
Hospitality Solutions.....	7
Design Guide	
Office Design Guide.....	8-9
Restroom Design Guide.....	10-11
Classroom Design Guide.....	12-13
Laboratories Design Guide.....	14-15
Conference Room Design Guide.....	16-17
Storage Area Design Guide.....	18-19

Coverage Patterns and Wiring Schematics

Coverage Patterns.....	20
Wall Switch Wiring Schematic.....	21
Ceiling Wiring Schematic.....	22-23

Energy Savings with Occupancy Sensors

Typical Applications



Wall Switch **Ceiling Sensor** **Wall Sensor**

Applications are generalized. Consult your Hubbell representative for the type of technology and products that fit your needs.

Application		Sensor Technology				Sensor Style		
		Adaptive	Dual	Ultrasonic	PIR	Wall Switch	Ceiling	Wall
Office	Small	✓+	✓+		✓	✓+	✓	
	Large	✓+	✓+	✓			✓+	
Open Office		✓+	✓	✓+			✓+	
Storage/ Warehouse	Small				✓+	✓+		
	Large	✓+			✓+		✓+	✓+
Rest Room	Small			✓+	✓+	✓+	✓	
	Large	✓+		✓+			✓+	
Conference Room	Small	✓+	✓+			✓+	✓	
	Large	✓+	✓+				✓+	
Classroom	Small	✓+	✓+			✓+	✓	
	Large	✓+	✓+				✓+	
Hall		✓+		✓+	✓		✓+	✓

Hubbell Occupancy Sensors Play a Key Role

In the U.S., lighting consumes 22% of electricity and represents \$40 billion a year in energy costs. Using advanced technology, Hubbell's H-MOSS® Occupancy Sensors are doing their part to save energy and provide sustainability by automatically and effectively turning lights on when a room is occupied and off when a room is vacant. In a typical office building, where lighting accounts for 35 to 45% of energy use, H-MOSS Occupancy Sensors have the potential to reduce wasted lighting by 13 to 90% for a significant return on investment (ROI).

Hubbell offers a broad range of occupancy and vacancy sensors and lighting controls that meet the latest codes and standards, including ASHRAE/IESNA 90.1 and California Energy Commission (CEC) Title 24. H-MOSS Occupancy Sensors can also provide LEED® points in categories like Sustainable Sites, Energy and Atmosphere, Indoor Environmental Quality and Innovative Design Process.

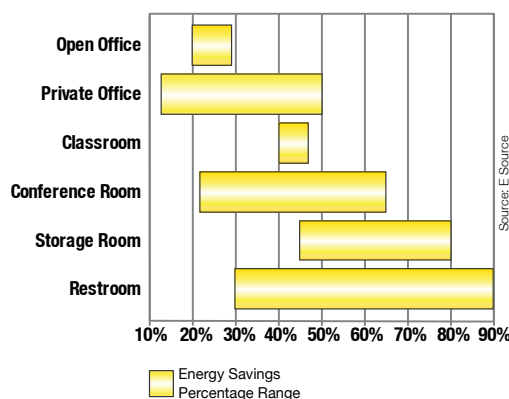

Backed by Hubbell Service and Support

H-MOSS® Occupancy Sensors are backed by Hubbell's GreenWise™ sustainability initiative and superior service and support including:

- Valuable online H-MOSS ROI worksheet for calculating energy savings
- Detailed H-MOSS online e-learning courses that can be taken anywhere, anytime
- Product selection guide for choosing the right H-MOSS Occupancy Sensor and technology
- Online specification assistance through spec wizard, AutoCAD drawings, templates, BIM objects and documentation
- Comprehensive design assistance for deploying occupancy sensors in a variety of applications
- Highly knowledgeable network of specification professionals and trained, dedicated sales staff
- Backed by Hubbell who is committed to safeguarding the environment through environmental stewardship, innovative products and efficient operations



Office Solutions

Energy Saving Locations:

- Supply Closets
- Restrooms
- Break Rooms
- Conference Rooms
- Offices
- Open Offices
- Hallways

Pro Tip:

Sensors with photocells provide additional savings in areas with sufficient natural light by turning off lights whenever possible.

Success Factors:

- Reduce installation and maintenance labor by eliminating manual adjustments with adaptive sensors.
- Maximize savings with Hubbell's daylight harvesting products which precisely control lighting in response to available natural light.
- Open office spaces provide many placement and product selection challenges. Contact your local Hubbell sensor professional for layout and product assistance.

* Energy Information Administration: 2003 Commercial Buildings Energy Consumption Survey

** Based on 40% lighting savings from sensors. Actual results may vary.



Eliminate energy waste and improve the bottom line.

Companies have always had to make tough decisions regarding resource allocation. In the past, energy consumption was often treated as a fixed overhead cost. With new regulations and the need for sustainable building design, this no longer holds true. Lighting is responsible for much of an office's electricity use, and occupancy sensors can provide significant energy savings by only lighting where and when it's needed.

Enhance reputation and maintain employee satisfaction.

Companies with LEED-certified facilities have a higher standing within their communities and among industry peers. LEED-certified work environments also result in higher levels of employee satisfaction and retention due to healthier, brighter working conditions. Hubbell's H-MOSS sensors can help gain LEED points and illustrate a company's commitment to protecting the environment.

Typical Office Electricity Usage and Savings*

Lighting Uses 39% of Total Electricity

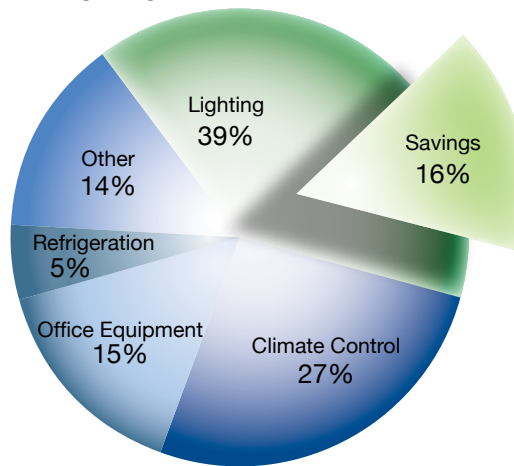

Potential electricity bill savings**

Application ROI Index

Faster Payback

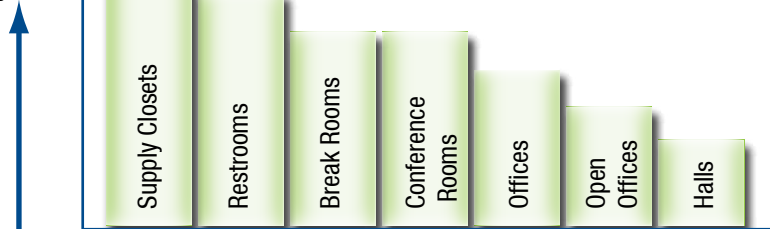

Based on average occupancy and installation complexity.

Education Solutions



Electricity doesn't educate—teachers do.

Electricity bills are second only to payroll in today's restricted school budgets. Most of the electricity goes to keeping the lights on, even when they are not needed. Systematically turning lights off whenever possible significantly reduces a school's utility bill.

Regain budget control with Hubbell.

H-MOSS® sensors provide a simple, automated and transparent system to make sure that lighting energy is used as needed. This protects school budgets from rate fluctuations, allowing educational institutions to more freely invest in teachers, programs and supplies that directly affect the quality of education.

Energy Saving Locations:

- Store Rooms
- Restrooms
- Cafeterias
- Administration
- Classrooms
- Media Centers
- Hallways

Pro Tip:

Dual technology sensors enhance minor motion detection reducing false off situations during periods of reading or testing.

Typical Education Electricity Usage and Savings*

Lighting Uses 31% of Total Electricity

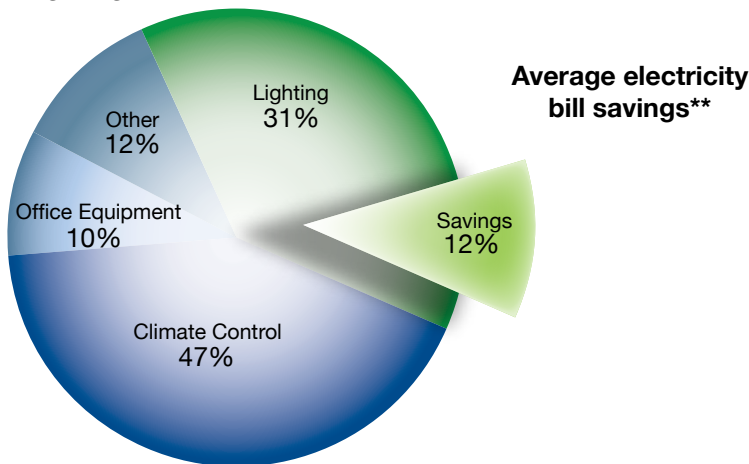

Success Factors:

- Provide advanced lighting control of two zones for projector use with dual circuit switches.
- Increase sensor longevity by specifying AD or AP series switch sensors with vandal resistant hard lenses or ultrasonic sensors.
- Simplify retrofits by eliminating the need to run new wires by utilizing line voltage wall switch and ceiling sensors.

Application ROI Index



Based on average occupancy and installation complexity.



* Energy Information Administration: 2003 Commercial Buildings Energy Consumption Survey
 ** Based on 40% lighting savings from sensors. Actual results may vary.

Healthcare Solutions

Energy Saving Locations:

- Store Rooms
- Restrooms
- Break Rooms
- Labs
- Exam Rooms
- Administration Offices
- Circulation

Pro Tip:

Adaptive Technology will automatically adjust for changes in shifts, usage, and seasons eliminating the need for manual adjustments and improving system performance.

Success Factors:

- Prevent lights from coming on at night in patient rooms by setting AP, AD, and AU series products to manual-on mode.
- Minimize privacy curtains and carts from preventing sensor activation by utilizing Dual Technology or Ultrasonic sensors.
- Healthcare facilities have many special requirements and unique environments. Contact your local Hubbell sensor professional for layout and product selection assistance.

* Energy Information Administration: 2003 Commercial Buildings Energy Consumption Survey

** Based on 40% lighting savings from sensors. Actual results may vary.



Turning lights off should be the least of the worries.

Hospitals are a 24/7 operation where decisions and actions regarding the wellness of patients are critical. Consequently, lights are often left on when not needed. There are several areas throughout hospitals that can realize substantial efficiency improvements with little investment like administration offices, storerooms, closets and break rooms. Private practices, medical labs and outpatient care facilities have lower occupancy rates than hospitals and can further benefit from occupancy sensors.

Promote healthier environments.

Light switches are one of the most commonly touched surfaces, spreading diseases and bacteria. Installing occupancy sensors where appropriate eliminates the need to touch a switch, which can help reduce the spread of pathogens. At the same time, healthcare staff benefit from a simple, user-friendly method of controlling the lights.

Typical Healthcare Electricity Usage and Savings*

Lighting Uses 42% of Total Electricity

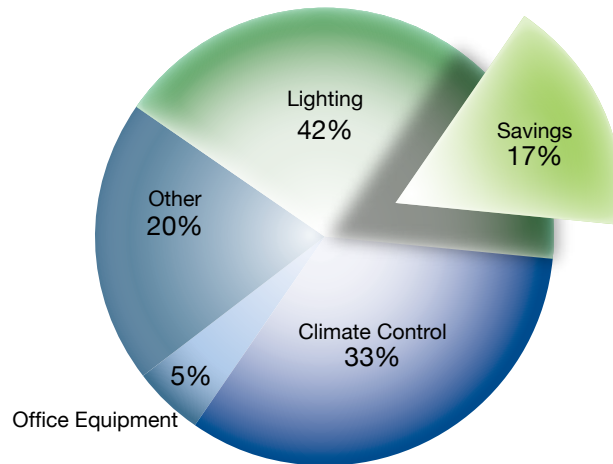

Average electricity bill savings**

Application ROI Index

Faster Payback

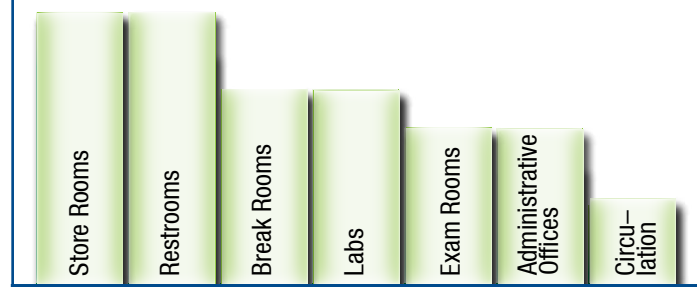

Based on average occupancy and installation complexity.

Hospitality Solutions



Turn the lights off to keep the lights on.

Over 50% of a hotel's electricity bill goes to keeping lights on, even when guests are away from their rooms. This results in substantial waste that reduces an establishment's financial efficiency and sustainability. With occupancy sensors, the waste can be eliminated without affecting customer comfort and convenience.

Manual-on mode automates savings.

Hotel guests are on the go and often away from their rooms. As a result room lights are often left on, even in broad daylight. Specifically developed with the hospitality industry in mind, manual-on mode provides guests with a traditional on/off light control experience but then automatically turn off lights once a room is unoccupied for a period of time. This provides a simple and transparent method to ensuring that lights are off when necessary, significantly increasing a hotel's energy efficiency.

Energy Saving Locations:

- Supply Closets
- Restrooms
- Exercise Rooms
- Break Rooms
- Meeting Rooms
- Guest Rooms
- Food Service
- Hallways

Pro Tip:

Utilize manual-on setting to maximize savings by making sure lights are turned off when rooms are unoccupied while giving patrons a traditional on/off experience.

Success Factors:

- Let guests have traditional control by setting sensors to manual-on mode on AP, AD, and AU series products.
- Utilize free sunlight to light your lobbies and atriums with Hubbell's atrium daylight harvesting sensor.
- Provide nighttime illumination with nightlight sensors.

Typical Hospitality Electricity Usage and Savings*

Lighting Uses 53% of Total Electricity

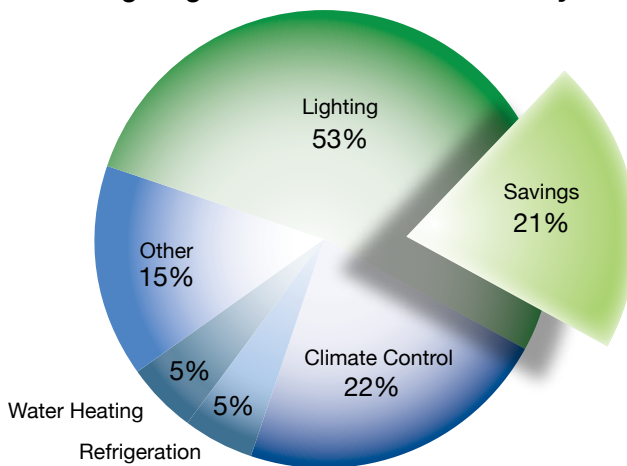

Average electricity bill savings**

Application ROI Index



Based on average occupancy and installation complexity.



Office Design Guide

Energy Saving Areas:

- Open Office
- Administration
- Private Offices
- Teaming Areas

Pro Tip:

Line voltage ceiling sensors simplify retrofits. Also note door location and swing radius to position wall switch sensors correctly.

Products

Recommended

Wall Switch:
AD2000x1 Series



Alternative

Wall Switches:
WS2000x Series
AP2000x1 Series

Ceiling Sensors:
ATD500C
ATP600C

(Must use a Control Unit
CU300A or CU300M)

LVPR1500R

(No control unit needed)



Occupancy trends are changing.

Due to the increased use of flexible work hours, telecommuting and adaptable workspaces, modern office spaces experience constant changing occupancy patterns. These trends have increased the amount of unnecessary illumination in today's offices, which can be minimized through proper utilization of occupancy sensors.

Modern technology for modern offices.

The ever-changing nature of today's office space poses challenges for traditional occupancy sensors. Hubbell's H-MOSS® sensors, equipped with adaptive technology, constantly monitor and adjust to changing occupancy patterns, layouts and environmental conditions. H-MOSS takes the guesswork out of setup and operation by providing an "install-and-forget" experience.

Typical Layouts and Coverage Patterns

Small Office

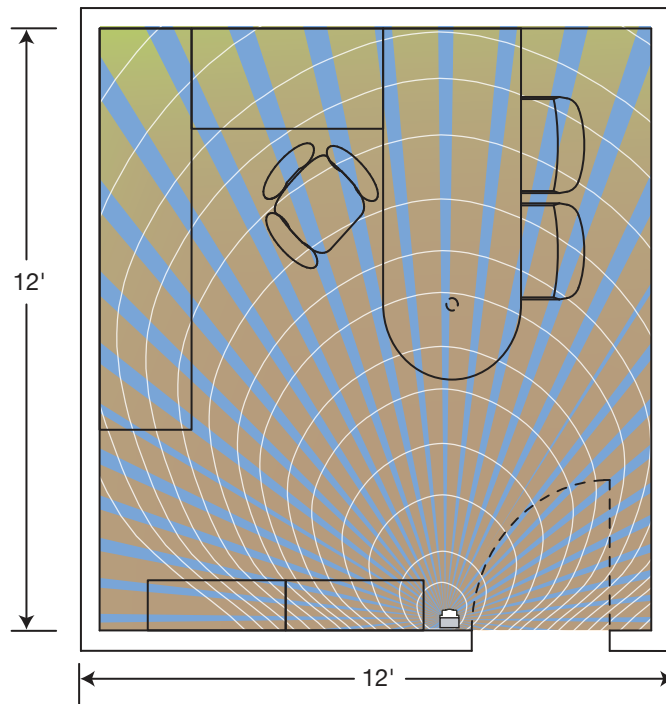

Technology

Adaptive Dual Technology
(Recommended)

Suggested Installation

Make sure sensor is not obscured by an open door.

Large Office

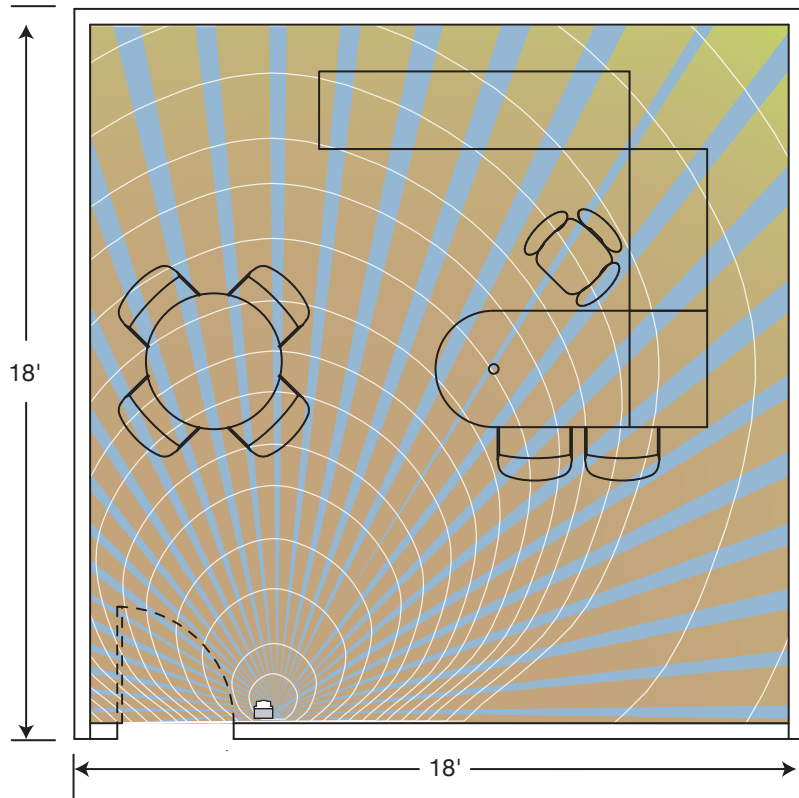

Technology
Adaptive Dual Technology
(Recommended)

Suggested Installation
Place sensor to view into the room
and not "see" hallway traffic.

Products

Recommended
Wall Switch:
AD2000x1 Series



Alternative
Ceiling Sensor:
ATU1000C
(Must use a Control Unit
CU300A or CU300M)

Open Office

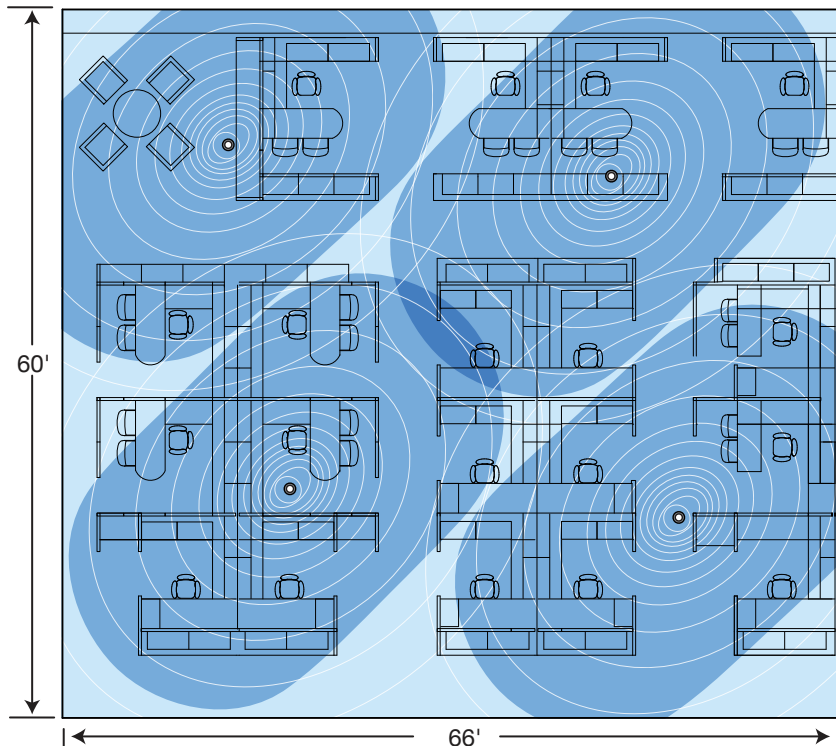

Technology
Adaptive Ultrasonic Technology
(Recommended)

Suggested Installation
Position and angle sensors to maximize
minor motion detection over work space
concentrations.

Products

Recommended
Ceiling Sensor:
ATU2000C



Must use Control Unit
CU300A or CU300M



Alternative
Ceiling Sensor:
ATD2000CL
(No control unit needed)

Restroom Design Guide

Energy Saving Areas:

- Single Person
- Multi Person
- Locker Rooms
- Powder Rooms

Pro Tip:

Dual circuit sensors can allow for control of lights and exhaust fan simplifying installation. Contact technical services regarding load and motor types supported.

Products

Recommended

Wall Sensors:
AU2000X1 Series



Alternative

Wall Switches:
WS2000x Series
AP2000x1 Series

Ceiling Sensors:
ATU500C

(Must use a Control Unit
CU300A or CU300M)

ATU2000CL

(No control unit needed)



Occupied or not?

Restrooms are typically occupied less than 50% of the day, and lights are often left on while no one is present. Restrooms are also isolated, making it difficult to determine if lights have been left on inadvertently. Significant savings can be achieved by systematically turning lights off when possible.

Promote savings and health.

H-MOSS® sensors intelligently sense occupation and control lights accordingly so facility managers no longer have to ensure that the lights are turned off in restrooms or when closing up. And because a switch is a common touch point for transmitting germs in bathrooms, using H-MOSS sensors helps promote healthy buildings.

Typical Layouts and Coverage Patterns

Small Single Restroom

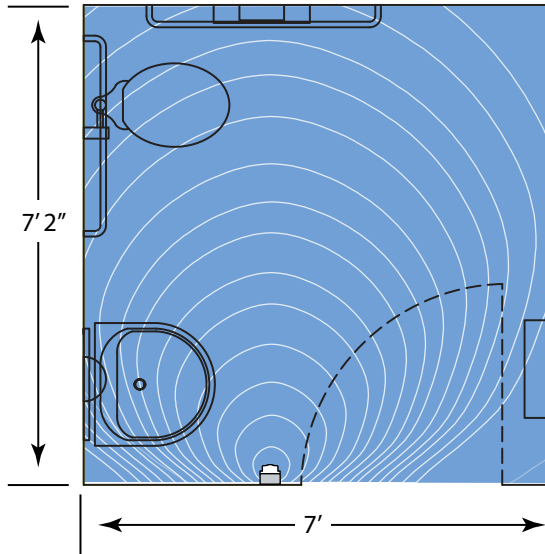

Technology

Adaptive Ultrasonic Technology
(Recommended)

Suggested Installation

Mount switch in location that limits chance for damage.

Large Restroom

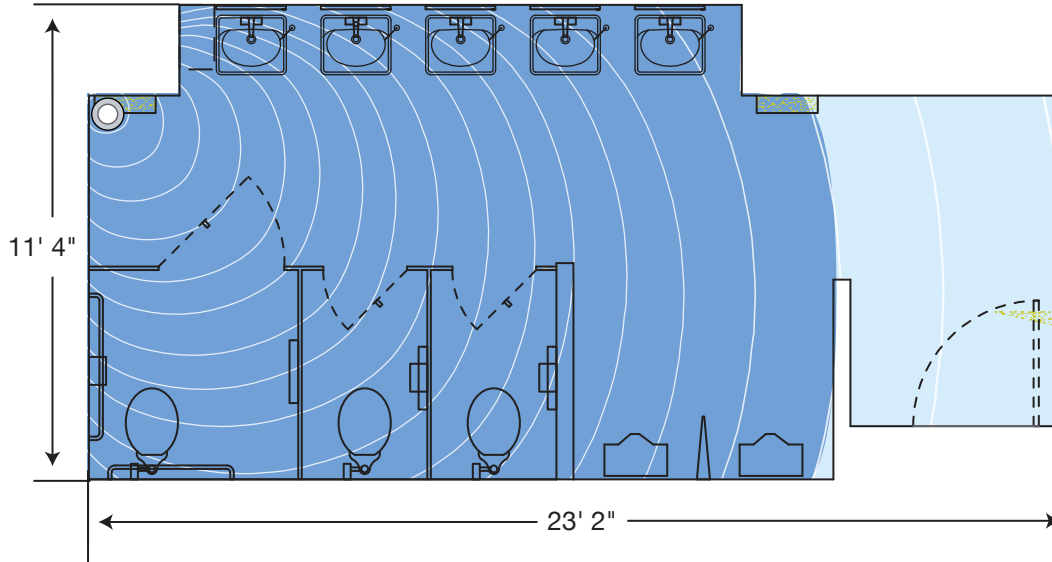

Technology

Adaptive Ultrasonic Technology
(Recommended)

Suggested Installation

Place sensor closer to stalls to maximize minor motion detection.

Products

Recommended

Ceiling Sensor:
ATU500C



Must use a Control Unit
CU300A or CU300M



Alternative

Ceiling Sensors:
ATU1000CL
(No control unit needed)

Large Restroom with Locker Room

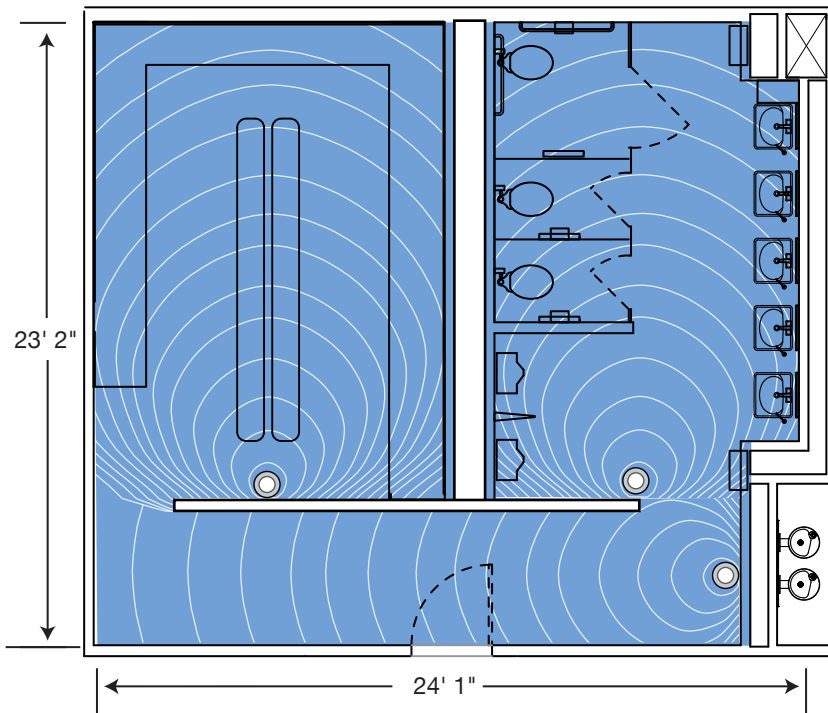

Technology

Adaptive Ultrasonic Technology
(Recommended)

Suggested Installation

Multiple sensors provide complete coverage and allow selective lighting based on occupancy.

Products

Recommended

Ceiling Sensor:
ATU500C



Must use a Control Unit
CU300A or CU300M



Alternative

Wall Sensor:
ATU2000C
(Must use Control Unit
CU300A or CU300M)

Ceiling Sensor:
ATU2000CL

(No control unit needed)



Classroom Design Guide

Energy Saving Areas:

- Classrooms
- Conference Halls
- Libraries

Pro Tip:

Dual technology provides reliable operation during periods of low activity such as testing. Manual on/off sensors provide control for movies and presentations.



H-MOSS® – the teacher's new pet.

Lighting classrooms consumes a substantial amount of the education budget. However, significant savings can be realized by turning off lights when they are not needed. Occupancy sensors provide an inexpensive way to guarantee that energy waste is kept to a minimum. They can further enhance savings by using optional photo sensors that turn off the lights when enough natural light is detected.

Design for change.

Classrooms are multi-use spaces that accommodate school-day activities and after school programs. Field trips, vacations, events and cancellations all affect occupancy patterns. At the same time, seasonal environmental conditions are always changing. Hubbell's patented Adaptive Technology automatically adjusts to these changes to minimize inadvertent activation and maximize savings. Hubbell provides one of the most complete sensor lines for effectively managing project cost and performance in educational institutions.

Products

Recommended

Ceiling Sensor:
ATD2000C



Must use a Control Unit
CU300A or CU300M



Alternative

Ceiling Sensor:
ATD2000CL

(No control unit needed)

Typical Layouts and Coverage Patterns

Large Classroom

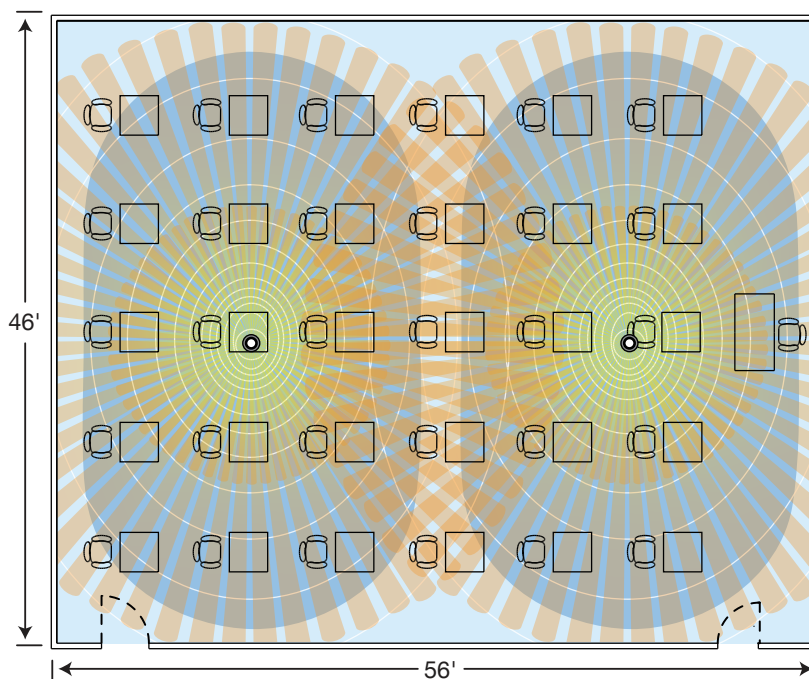

Technology

Adaptive Dual Technology (Recommended)

Suggested Installation

Provide teachers with manual override switches to turn off lights during A/V presentations.

Library

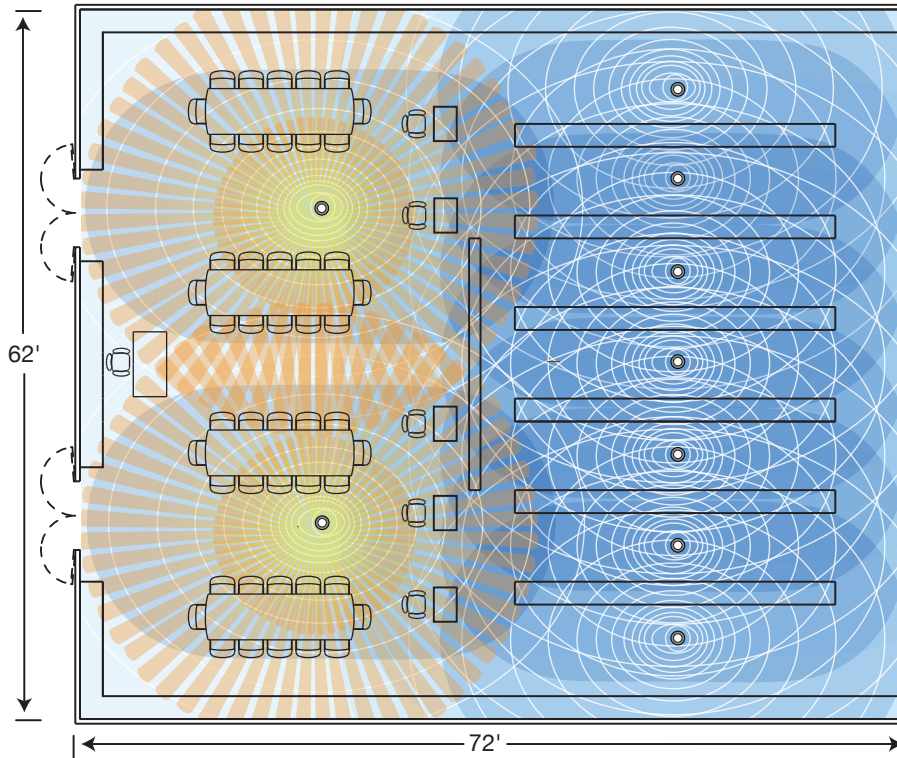

Technology

Adaptive Dual Technology (Recommended for sitting area)

Adaptive Ultrasonic Technology (Recommended for browsing area)

Suggested Installation

Utilize ultrasonic sensors between book case stacks to eliminate blind spots.

Lower Grade Elementary Class

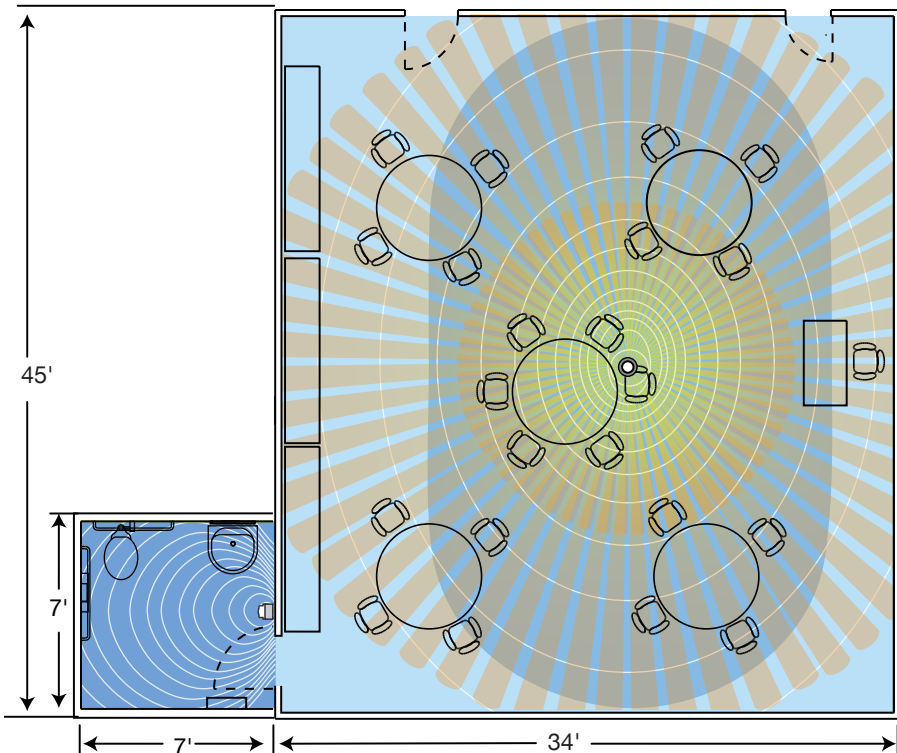

Technology

Adaptive Dual Technology (Recommended for classroom)

Adaptive Ultrasonic Technology (Recommended for bathroom)

Suggested Installation

Provide teachers with manual override switches to turn off lights for quiet times.

Minor Motion: ■ Ultrasonic ■ PIR Major Motion: ■ Ultrasonic ■ PIR

Products

Recommended

Ceiling Sensors:

ATD2000C



ATU2000C



Both must use a

Control Unit

CU300A or CU300M



Products

Recommended

Ceiling Sensor:

ATD2000C



Must use a Control Unit

CU300A or CU300M



Wall Switches:

AU2000X1 Series

AU2000X1N Series



Laboratories Design Guide

Energy Saving Areas:

- Pharmaceutical Labs
- Quality Control Areas
- Product Development Labs
- Rapid Prototyping Shops

Pro Tip:

Use Dual Technology or Ultrasonic in labs with obstructions such as large filing cabinets or air flow hoods.

Products

Recommended

- Wall Switches:
- AU2000X1 Series**
- AU2000X1N Series**



Alternative

- Wall Switches:
- WS2000x Series**
- AP2000x1 Series**

- Ceiling Sensors:
- ATU500C**

(Must use a Control Unit **CU300A** or **CU300M**)

ATP1500CL

(No control unit needed)



Labs have unique requirements

Laboratory spaces are unique environments that have uncommon usage patterns and requirements, such as clean room classification. Lab technicians and scientists often have their hands occupied dealing with equipment, chemicals or biomaterials. In addition, occupancy constantly changes in labs. Even though lighting is often not needed for prolonged periods of time, lights are often left on.

Sensors—clean and efficient.

Hubbell's H-MOSS occupancy sensors provide a helpful way of automating energy savings. At the same time, they enhance the operation of the lab environment by allowing users to focus on their work instead of managing the lights. Ideal for the clean room environment, sensors have fewer moving parts that minimize foreign particulate generation and smooth surfaces that can be more easily cleaned. Hubbell's H-MOSS sensors not only save money, they provide a more efficient work environment.

Typical Layouts and Coverage Patterns

Small Laboratories

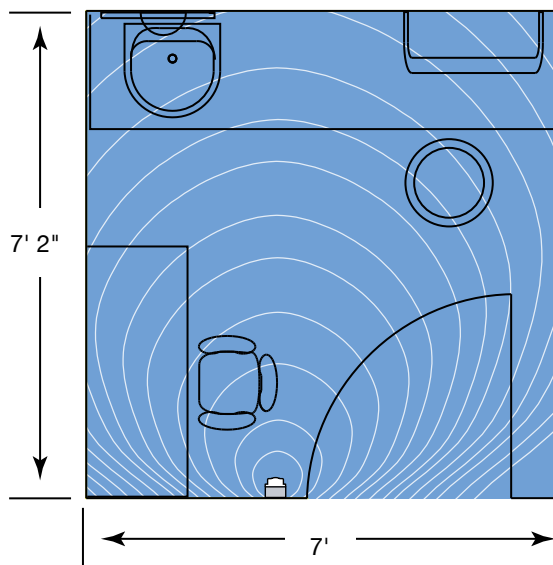

Technology

Adaptive Ultrasonic Technology
(Recommended)

Suggested Installation

Utilize PIR to prevent detection of minor equipment motions.

Large Laboratories

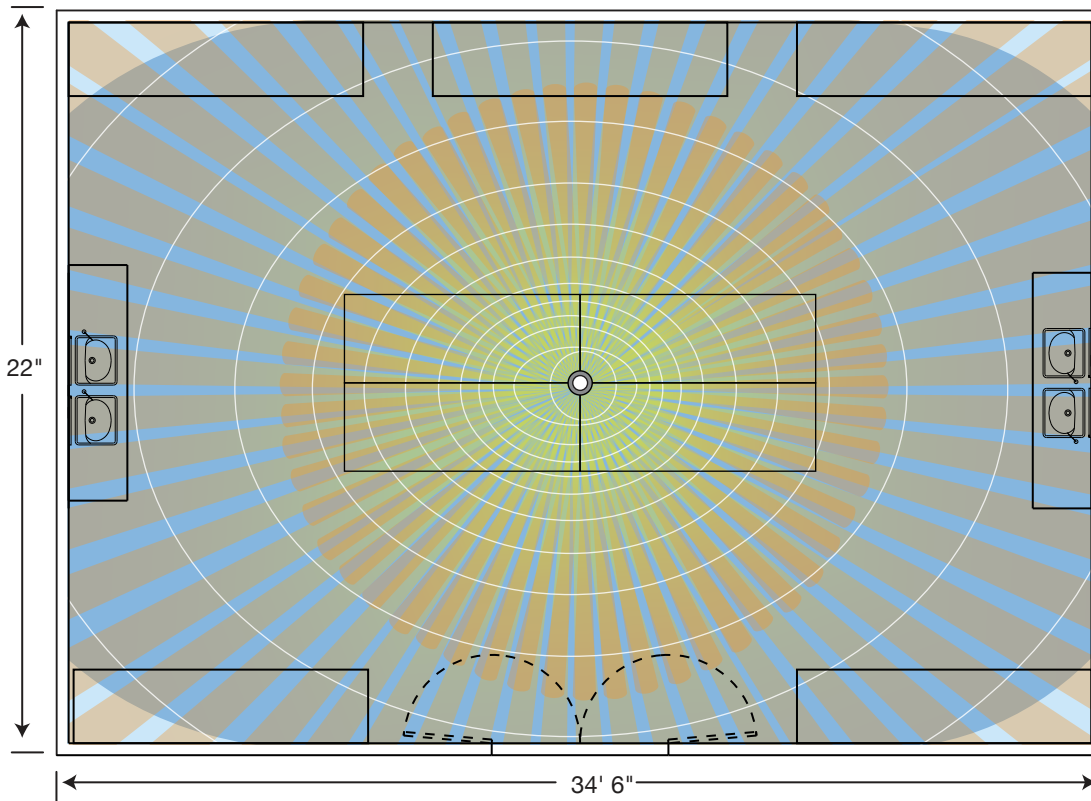

Technology

Adaptive Dual Technology
(Recommended)

Suggested Installation

Determine equipment placement to position sensors accordingly.
Multiple sensors may be required if large equipment is present.

Computer Lab

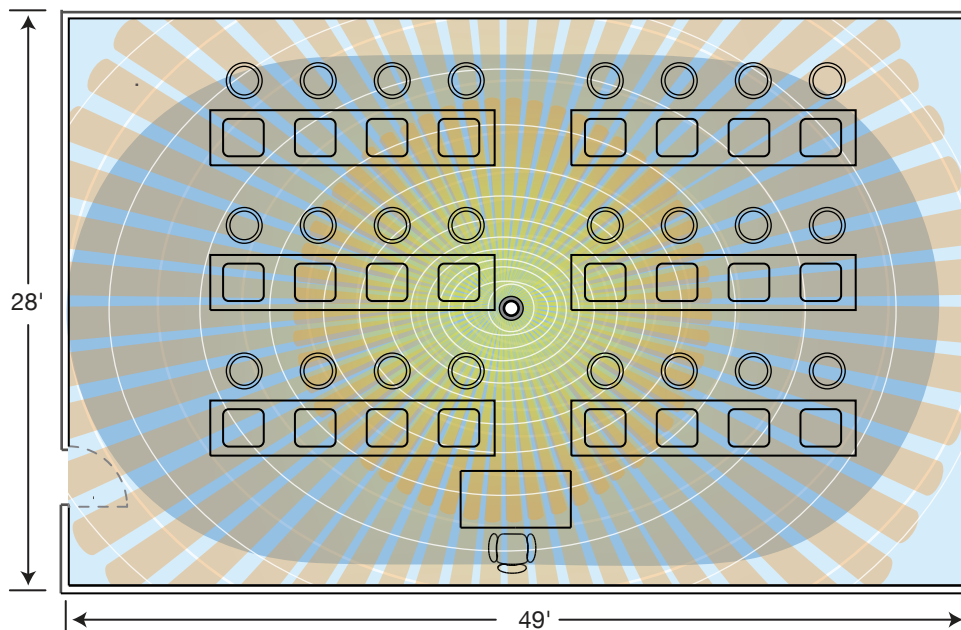

Technology

Adaptive Dual Technology (Recommended)

Suggested Installation

Centering sensor over the seating area maximizes detection of minor motion like typing.

Minor Motion: ■ Ultrasonic ■ PIR Major Motion: ■ Ultrasonic ■ PIR

Products

Recommended

Ceiling Sensor:
ATD2000C



Must use a Control Unit
CU300A or CU300M



Alternative

Ceiling Sensor:
ATD2000CL

(No control unit needed)

Products

Recommended

Ceiling Sensor:
ATD2000C



Must use a Control Unit
CU300A or CU300M



Alternative

Ceiling Sensor:
ATD2000CL

(No control unit needed)



Conference Room Design Guide

Energy Saving Areas:

- Large Boardrooms
- Small Boardrooms
- Training Rooms
- Teaming Areas

Pro Tip:

Use sensors with manual on/off control for projection of presentations.

Products

Recommended

Wall Switch:
AD2000x1 Series



Alternative

Ceiling Sensor:
ATD1000C

(Must use a Control Unit
CU300A or CU300M)



A place of purpose

Conference rooms are critical, bringing great minds together to develop strategies for success, but these meetings of the minds don't always happen all day long. People come and go, and even day-long meetings often break for significant periods of time. Still, lights are often left on when meetings adjourn and conference rooms are left empty. In addition, productivity increases with natural light, often making lighting unnecessary where windows can take over.

Portraying the right image

The irregular occupancy pattern of conference rooms makes these spaces ideal for Hubbell occupancy sensors. The use of photocell sensors ensures productive natural light is utilized when detected. Manual controls avoid lights coming on during audio-visual projection despite movement in the room. Because conference rooms are also often frequented by guests, they portray an image to meeting guests and attendees. No better image could be portrayed than a commitment to the environment through the use of occupancy sensors.

Typical Layouts and Coverage Patterns

Small Conference Room

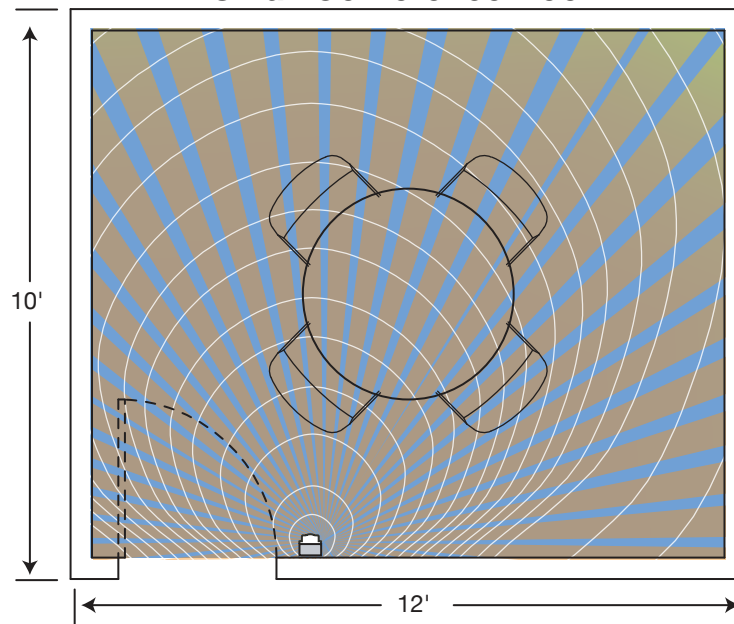

Technology

Adaptive Dual Technology (Recommended)

Suggested Installation

Make sure sensor is not obscured by presentation equipment like screens or easels.

Large Conference Room

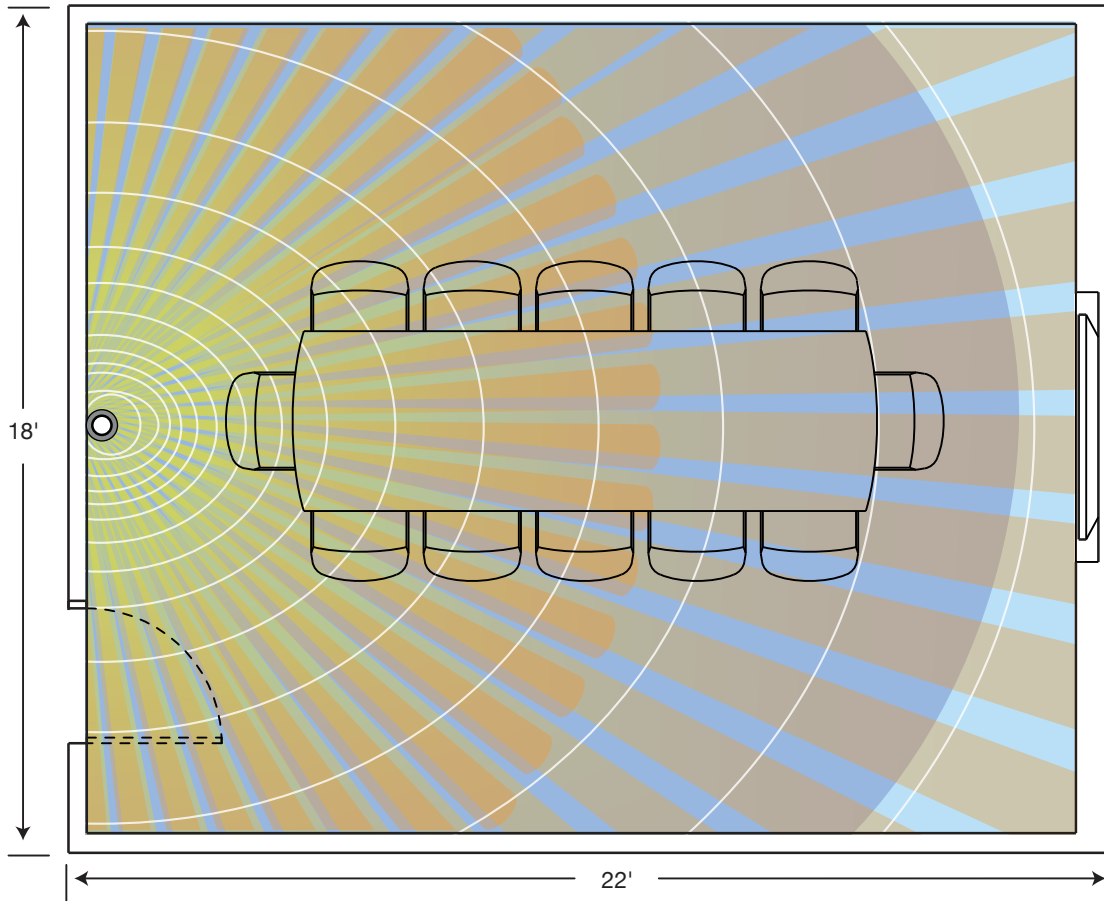

Technology

Adaptive Dual Technology (Recommended)

Suggested Installation

Dual circuit wall switches can be used to allow accent lighting during presentations if room size allows.

Products

Recommended

Ceiling Sensor:
ATD1000C



Must use a Control Unit
CU300A or CU300M



Alternative

Ceiling Sensor:
ATD2000CL

(No control unit needed)



Energy Saving Areas:

- Warehouses
- Supply Closets
- Storerooms
- Utility Closets
- Network Closets

Pro Tip:

Set short delays for small supply closets and store rooms to maximize savings.

Products

Recommended

Wall Switch:
WS2000x Series



Alternative

Ceiling Sensor:
ATP600C

(Must use a Control Unit
CU300A or CU300M)

Storage Area Design Guide



Frequently forgotten

Closets and storerooms offer one of the best environments for occupancy savings due to intermittent use. Furthermore, people leaving these spaces are often carrying supplies or merchandise, making turning off lights difficult. People then move on to the task at hand. Going back to turn off lights is frequently forgotten. Like restrooms, closets and storerooms are normally isolated, and it's difficult to determine if lights have been left on.

Easy in, easy out

With occupancy sensors, entering or leaving a storeroom with hands full is easily accomplished without worrying about the lights staying on and wasting energy. Hubbell H-MOSS breadth of products includes occupancy sensors with passive infrared technology that are ideal for small spaces of major movement, as well as options for covering large warehouse aisles and high-bay applications with 120-foot linear coverage.

Typical Layouts and Coverage Patterns

Small Closet/Storeroom

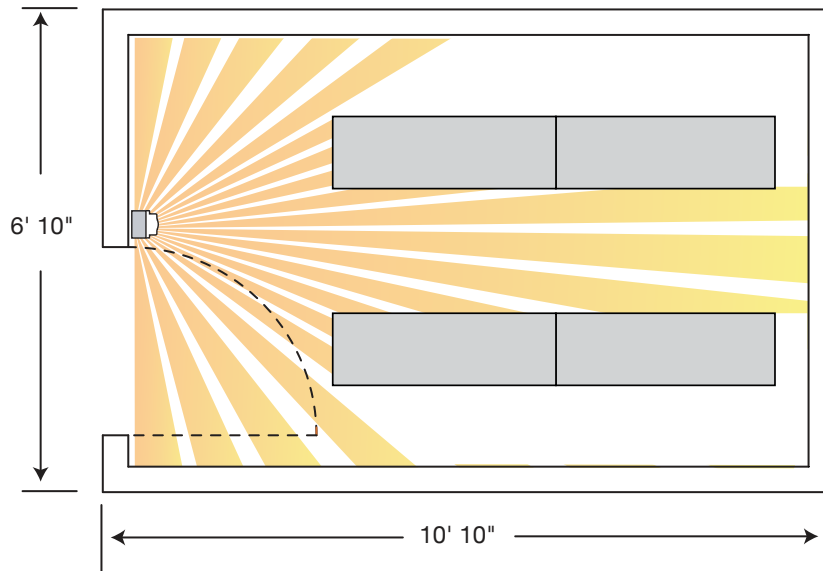

Technology

Adaptive Passive Infrared Technology
(Recommended)

Suggested Installation

Position sensor close to door to make sure lights come on when the door is opened.

Large Closet/Storeroom

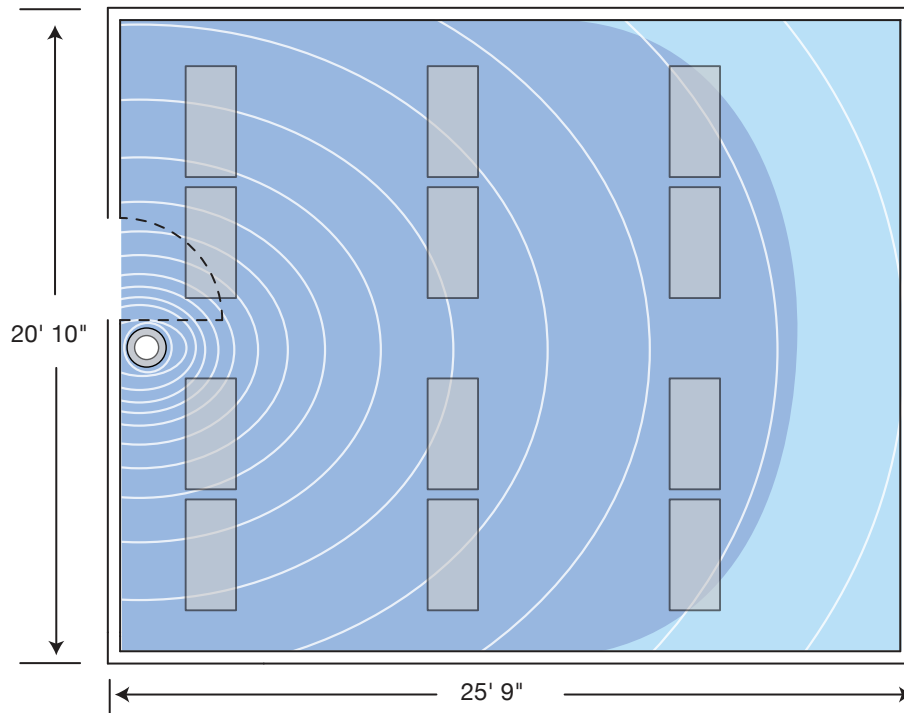

Technology

Adaptive Dual Technology
(Recommended)

Suggested Installation

Use a wall mount sensor if ceiling height is above 12ft.

Products

Recommended

Wall Mount Sensor:
ATU1000C



Must use a Control Unit
CU300A or CU300M



Alternative

Ceiling Sensor:
ATU2000C

(Must use a Control Unit
CU300A or CU300M)

Warehouse

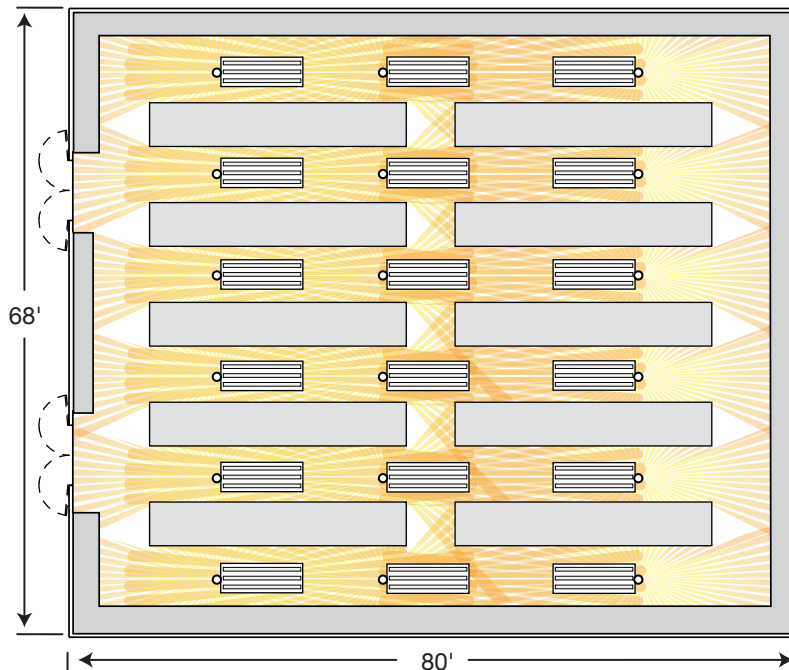

Technology

Passive Infrared Adaptive Technology
(Recommended)

Suggested Installation

Utilize fixture mount high bay sensors in larger areas or where wall sensors are not feasible.

Products

Recommended

Ceiling Sensor:
HMHB2x9 Series



Alternative

Wall Mount Sensor:
ATP120HB

Coverage Pattern

Wall Switch Sensors Minor Motion: ■ Ultrasonic ■ PIR Major Motion: ■ Ultrasonic ■ PIR

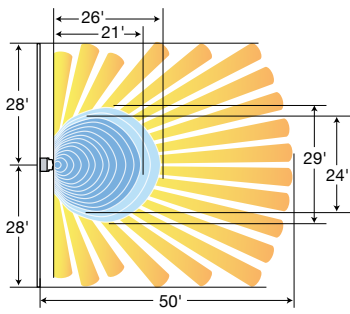

AD2000 Series

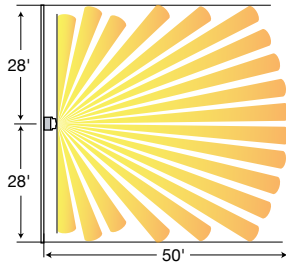

AP2000 Series

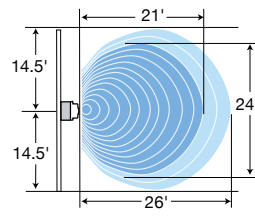

AU2000 Series

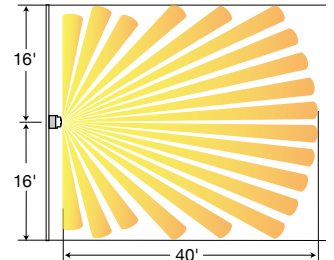

AT1277 Series

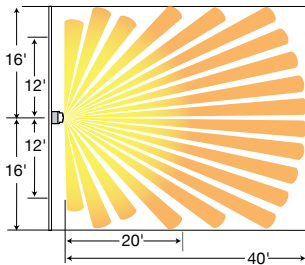

ATP2000, WS2000 Series

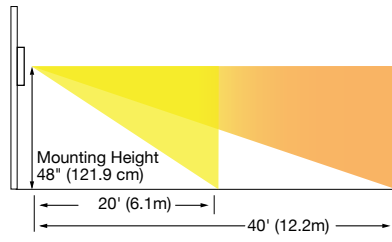

**Vertical Coverage
ATP2000, WS2000 Series**

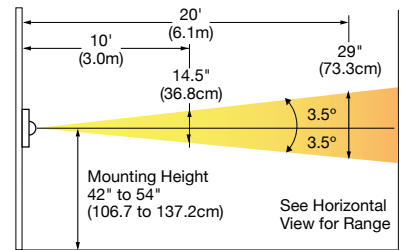

Vertical Coverage AT1277 Series

Ceiling Sensors

Minor Motion: ■ Ultrasonic ■ PIR Major Motion: ■ Ultrasonic ■ PIR

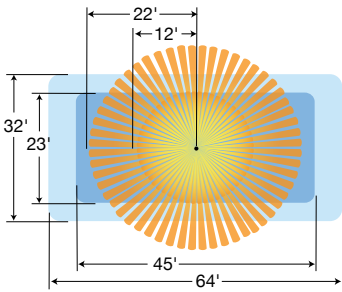

ATD2000C Series

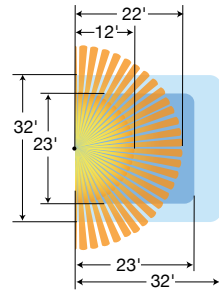

ATD1000C Series

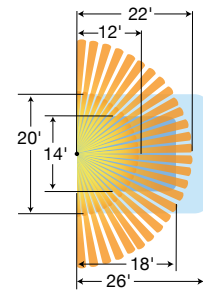

ATD500C Series

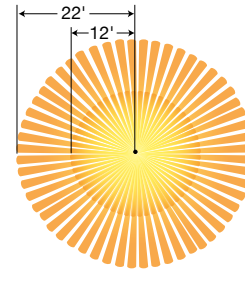

ATP1500C Series

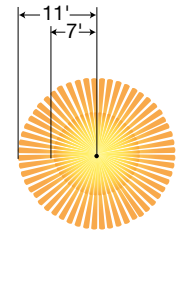

ATP600C Series

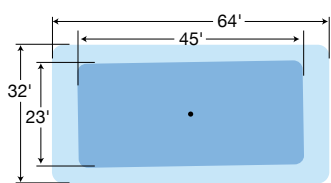

ATU2000C Series

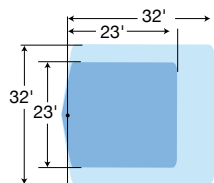

ATU1000C Series

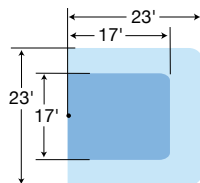

ATU500C Series

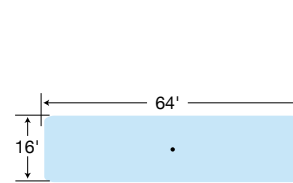

**ATU2000C Series
Hallway Application**

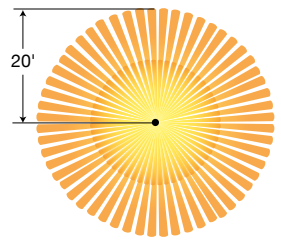

LVPR1500R(P)

Wall Mount Sensors

Minor Motion: ■ Ultrasonic ■ PIR Major Motion: ■ Ultrasonic ■ PIR

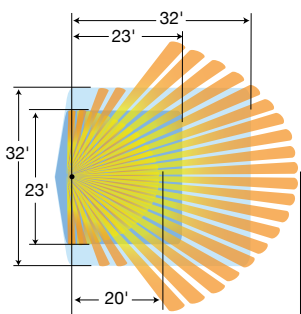

ATD1600W Series

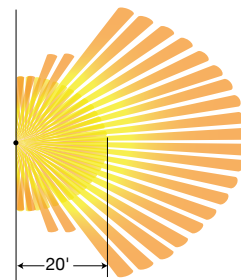

ATP1600W Series

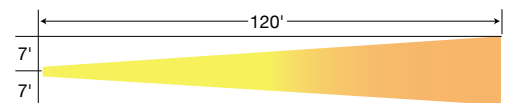

**ATP120HB Series
Top View**

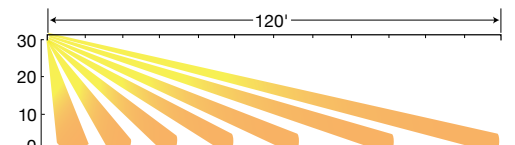

Side View

Wiring Schematic

AD, AU, AP, 2000 Series Wall Switch Sensors

Single Circuit Wiring

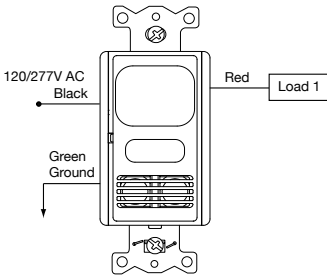

Dual Circuit Sensor, Wired for Dual Circuits

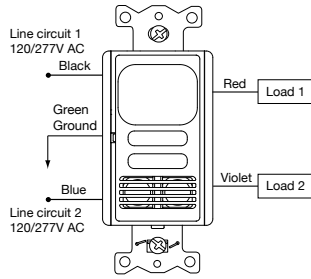

Dual Circuit Sensor, Wired for Single Circuit

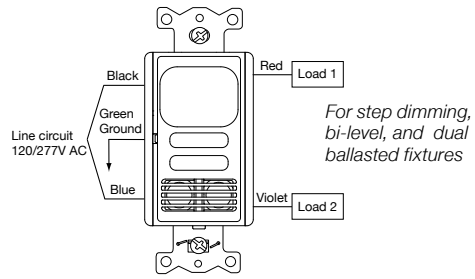

Single Circuit Sensors, Wired as 3-Way Sensors*

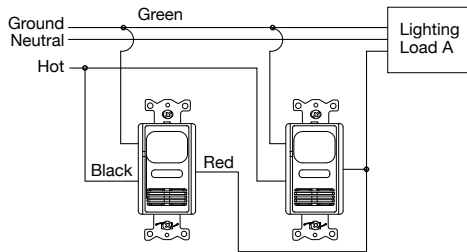

Dual Circuit Sensors, Wired as 3-Way Sensors*

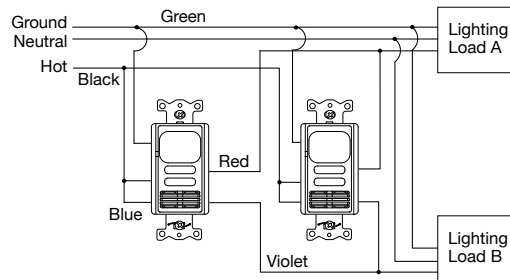

**Load can not exceed the rating of one switch. Sensor is shipped with all dip switches in the OFF position (factory default).*

ATP2000 and WS2000 Series Wall Switches

Normal Wiring

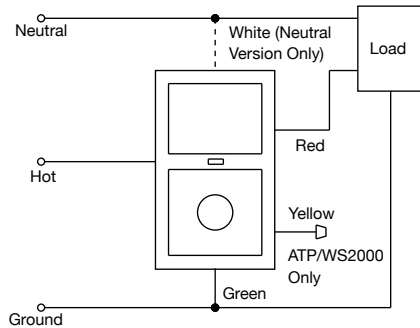

Sensors Wired as 3-Way Sensors*
(ATP/WS2000 Only)

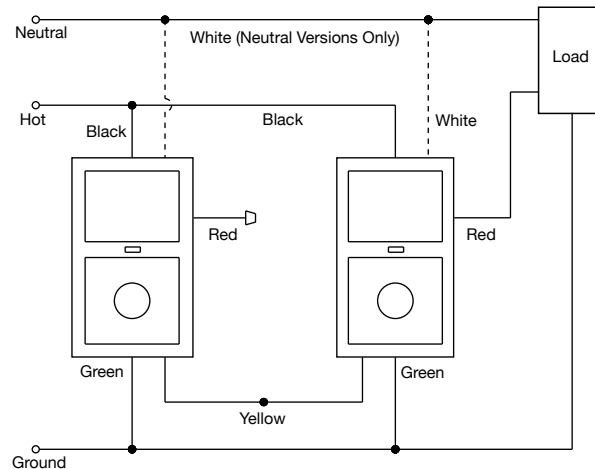

Wiring Schematic

Adaptive Dual Technology, Ultrasonic, and Passive Infrared Ceiling and Wall Mount Sensors ATD, ATU and ATP Series

Single Circuit Application:

1 to 4 sensors wired to control unit with optional override off switch.

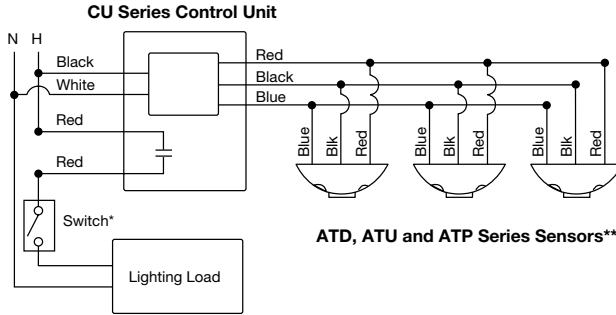

*Optional Override Off Switch

Two Circuit Application:

1 to 4 sensors wired to control unit and Add-A-Relay (control unit switches circuit 1, Add-A-Relay switches circuit 2).

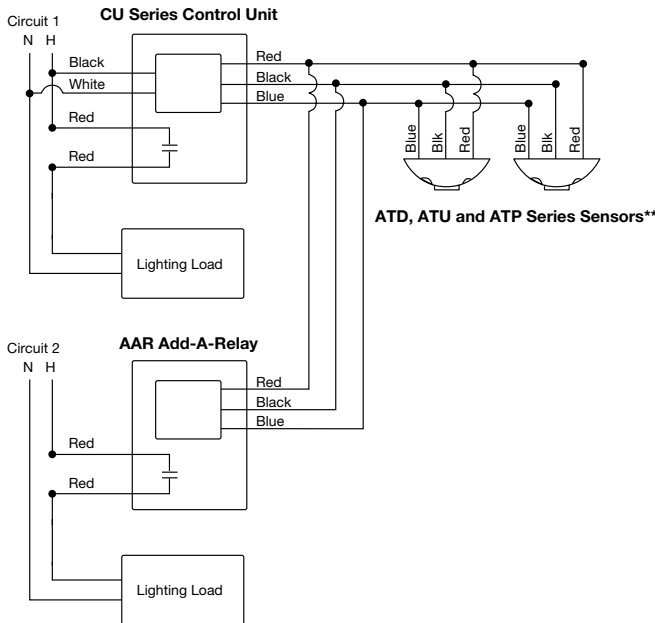

Single Circuit Application:

Two control units wired in parallel to operate 5 to 8 sensors in a single zone. Maximum 4 sensors per control unit any sensor will activate lighting.

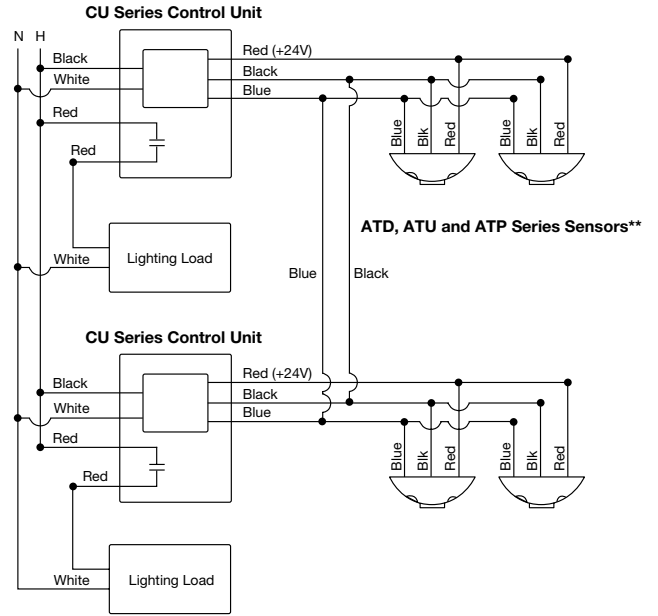

Two Circuit Application:

Two control units wired in two circuits to operate 2 to 8 sensors in a single zone. Maximum 4 sensors per control unit any sensor will activate both lighting loads.

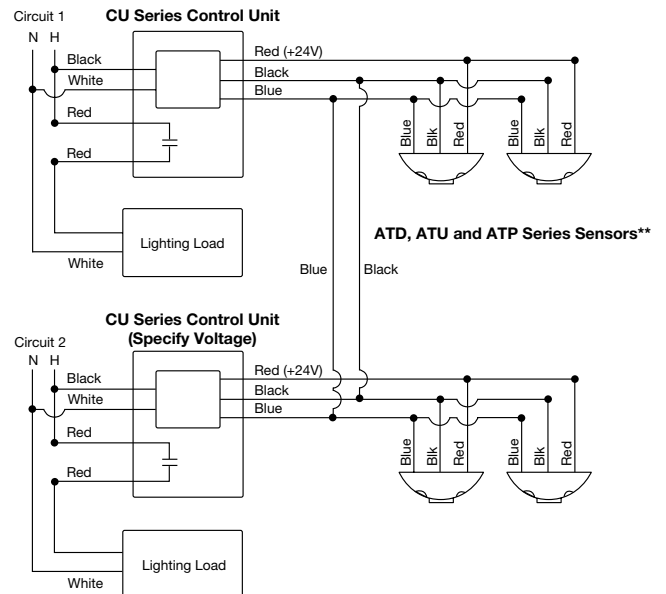

**For wiring sensors with isolated relay and photocell option (models with "RP" suffix): Photocell Option: Cap off Blue sensor wire. Connect Gray sensor wire to Blue control unit wire. Isolated Relay Option: Common-Blue/White wire, Normally Closed-Black/White wire, Normally Open-Yellow/White wire.

Wiring Schematic

Adaptive Technology Dual, Ultrasonic, and Passive Infrared Ceiling and Wall Mount Sensors ATD, ATU and ATP Series

Single Circuit, Dual Level Switching Application:
1 to 4 sensors wired to control unit with optional override off switches.

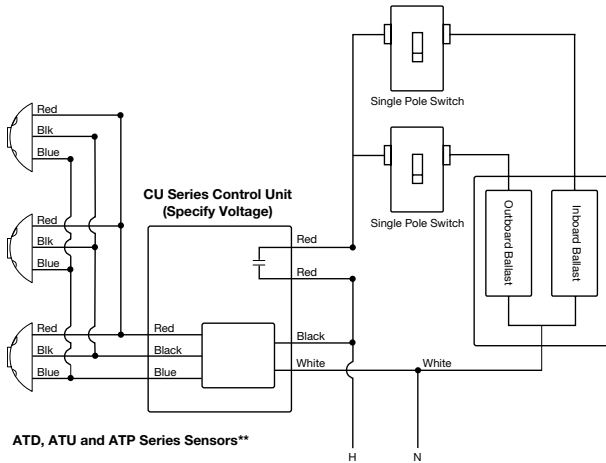

Single Circuit, 3-Way Switching Application:
1 to 4 sensors wired to control unit with optional override off switches.

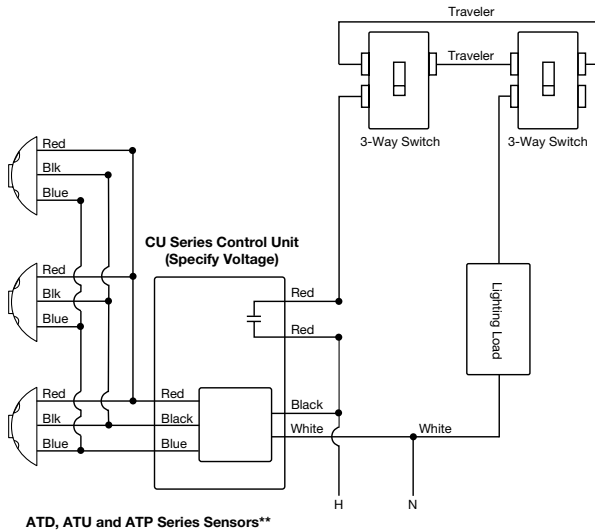

Multi-Circuit Application:
1 to 4 sensors wired to control unit that is wired to a multi-pole lighting contactor.

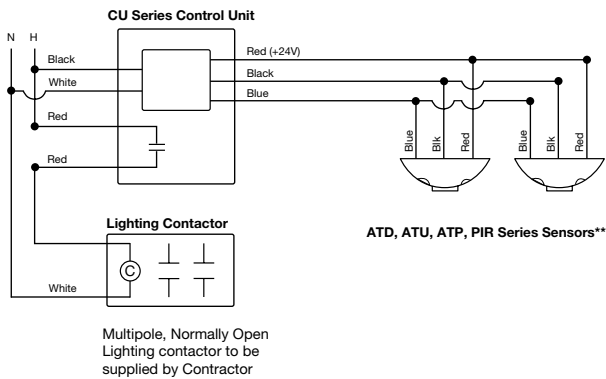

Single Circuit, 4-Way Switching Application:
1 to 4 sensors wired to control unit with optional override off switches.

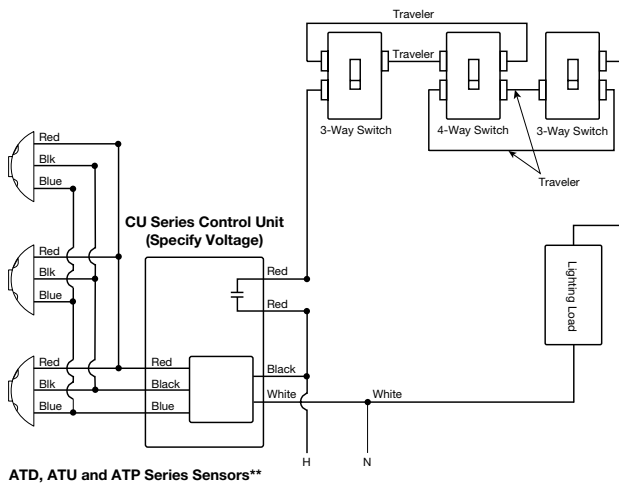

**For wiring sensors with isolated relay and photocell option (models with "RP" suffix): Photocell Option: Cap off Blue sensor wire. Connect Gray sensor wire to Blue control unit wire. Isolated Relay Option: Common-Blue/White wire, Normally Closed-Black/White wire, Normally Open-Yellow/White wire.

H-MOSS®



HUBBELL®
Wiring Device-Kellems

www.hubbell-wiring.com



Hubbell Wiring Device-Kellems
Hubbell Incorporated (Delaware)
40 Waterview Drive, Shelton, CT 06484
Phone (800) 288-6000 • FAX (800) 255-1031

Printed in U.S.A. Specifications subject to change without notice. H-MOSS® is a registered trademarks of Hubbell Incorporated.

WLBHM002 3/11