

M-12357

1

CONCENTRIC KNOCKOUTS

LOCATION	QUANTITY	TRADE SIZE
ENDS	1/END	1/2", 3/4", 1"
SIDES	2/SIDE	1/2", 3/4", 1"
BOTTOM	4	1/2", 3/4", 1"

LIST OF PARTS

DESCRIPTION	MATERIAL	FINISH
BOX ASSEMBLY	16 GA. STEEL	ZINC **
TOP MOUNTING ASSY	14 GA. STEEL	ZINC
TRANSITION ASSY	14 GA. STEEL	ZINC
GROUND WIRES	COPPER	
WIRING CHANNEL	16 GA. STEEL	ZINC
FASTENERS	STEEL	ZINC
TEMPORARY COVER	14 GA. STEEL	ZINC

** CATALOG NO. CFB2G25RCR BOX ASSEMBLY IS GALVANIZED AND EPOXY COATED ON EXTERIOR SURFACE.

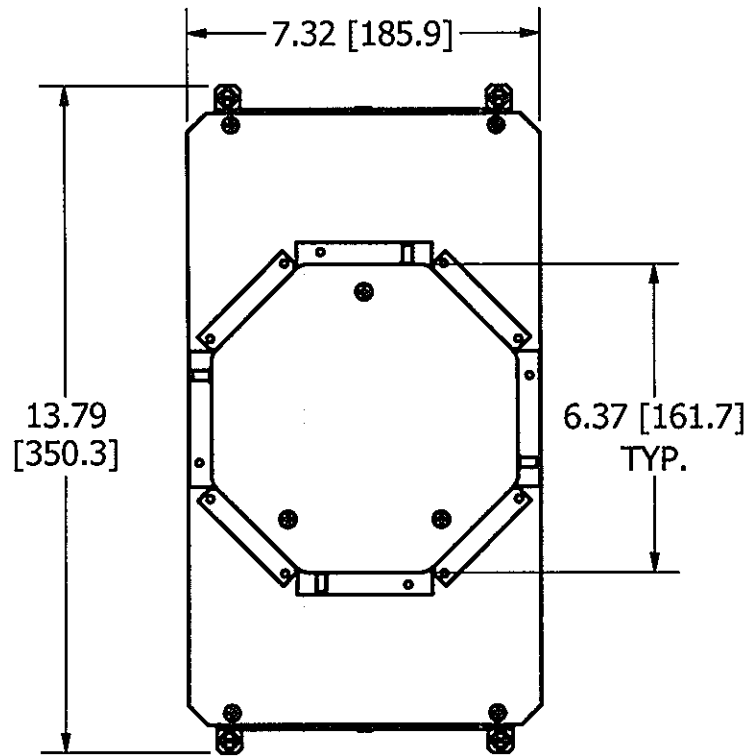

TOP VIEW

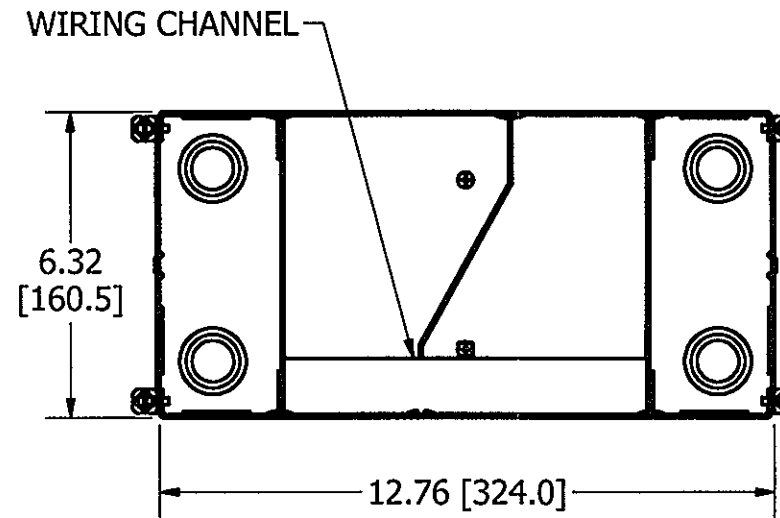

SECTION A-A
VIEW THROUGH BOX BELOW TRANSITION

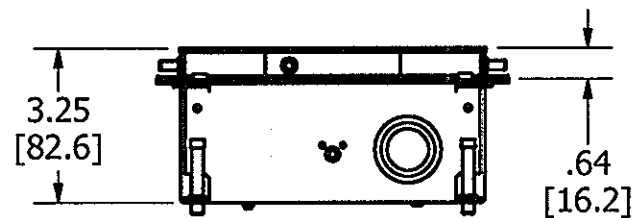

END VIEW

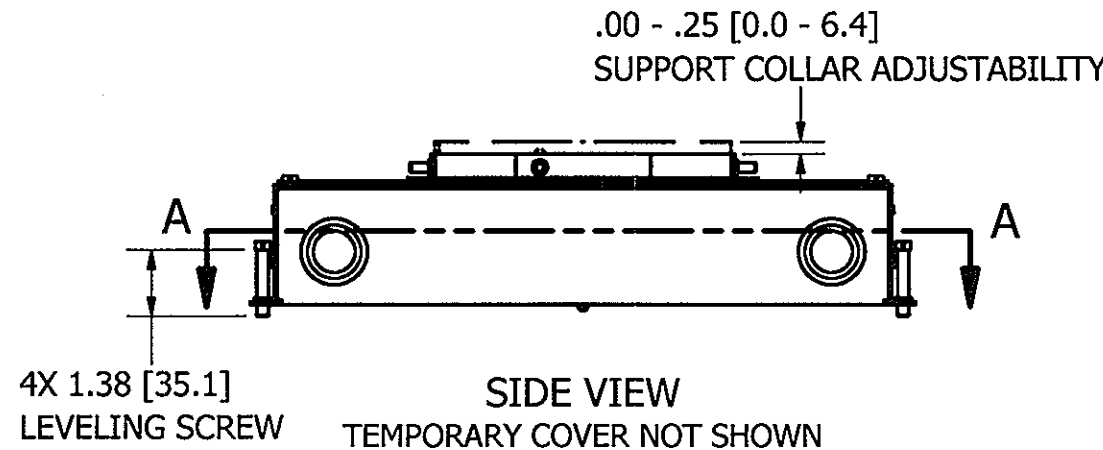

SIDE VIEW
TEMPORARY COVER NOT SHOWN

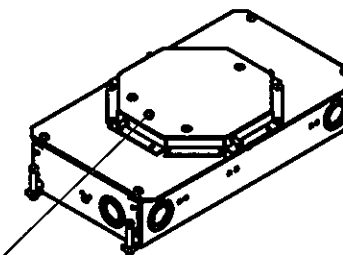

TEMPORARY COVER
ISOMETRIC

NOTES:

1. ALL DIMENSIONS ARE IN INCHES AND [MILLIMETERS].
2. PRODUCT IS cULus LISTED. COMPLIES WITH UL 514A.
3. EACH GANG SUPPLIED WITH 6" [152.4] 12 GA. AWG GROUND PIGTAIL.
4. MINIMUM CONCRETE POUR: 3.25" [82.6].
5. WIRING CHAMBER VOLUMES : (2) 30 IN³ [491.7 CM³].
6. WIRING CHANNEL AREA: .39 IN² [251 MM²].

CODE 74545

DIMENSION SHEET FOR CAT. NO.

CFB2G25R, CFB2G25RCR

REPAIRABLE

NON-REPAIRABLE

B

M-12357

1

1	INITIAL RELEASE PER DCN19233	SBW	11/15/13
SYM	DESCRIPTION	APP	DATE

THE DESIGN AND DIMENSIONS OF THE PRODUCT SHOWN ON THIS DRAWING ARE SUBJECT TO CHANGE WITHOUT NOTICE

TITLE
CONCRETE FLOOR BOX, 2 GANG FOR 6" ROUND COVER, SHALLOW

TOLERANCES UNLESS OTHERWISE SPECIFIED .XX = ± .01 .XXX = ± .005 ANGLES = ± 2°	WIRING DEVICE-KELLEMS HUBBELL INCORPORATED SHELTON, CT.		
	DR. BY	SBW	APP. BY
	TR. BY		SCALE 1/4
	CHK'D BY	SM	DATE 9/19/2013